

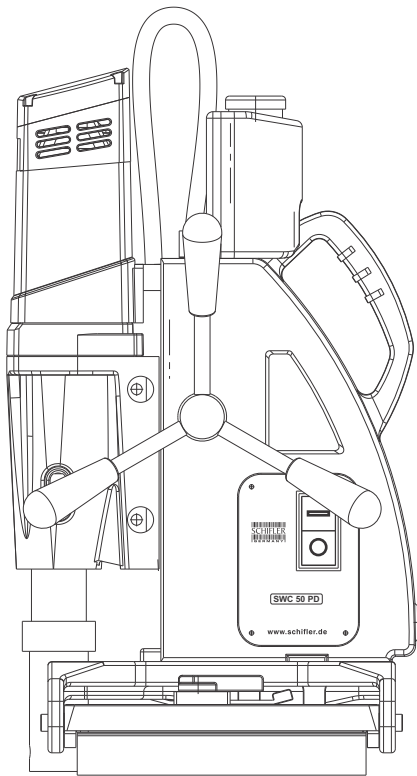

Magnetic Drilling Machine



SWC 50 PD



OPERATING MANUAL

Table of contents

1. Description & Technical Data
2. Components Content
3. Safety Procedures
4. Accessories
5. Operating manual
 - 5.1 How to mount tools or adapters in a Weldon arbor
 - 5.2 Drilling with broach cutters
 - 5.3 Drilling with twist drills
 - 5.4 Speed Selection
 - 5.5 Counter Sinking
 - 5.6 Pipe Drilling Magnet Base
 - a. Activating the Magnets
 - b. Deactivating the Magnets
6. Exploded View
7. Helpful Tips
8. Troubleshooting

DESCRIPTION & TECHNICAL DATA

SWC 50 PD

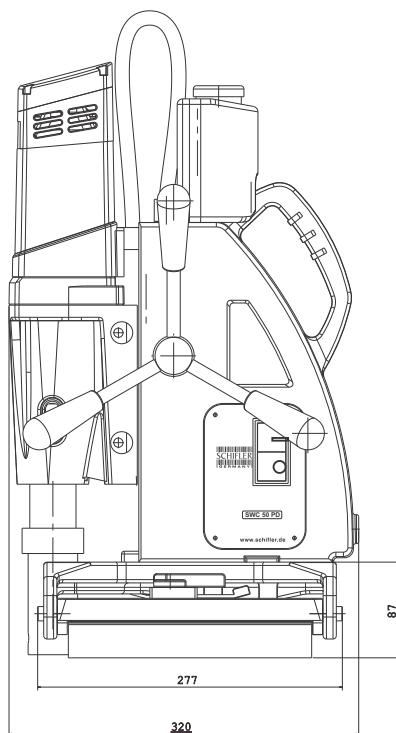
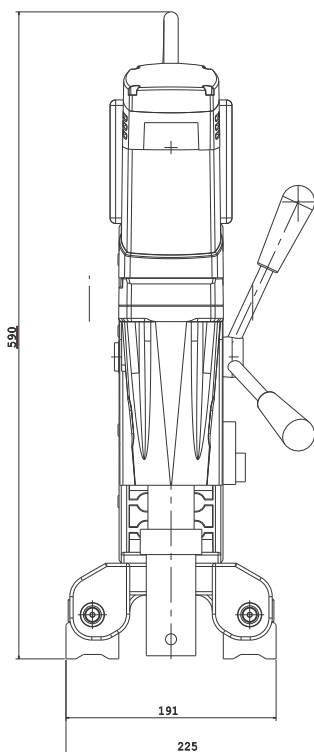

Motor power	1500 watt
Spindle	MT3, 19 mm Weldon
Broach cutter (35 mm length)	ø 12 mm - ø 50 mm
Broach cutter (50 mm length)	ø 12 mm - ø 50 mm
Broach cutter (80 mm length)	ø 18 mm - ø 26 mm
Twist drill	ø 23 mm
RPM	250 min-1/450 min-1
Stroke	Flexible Stroke upto 205 mm
Smallest Pipe Diameter	80 mm (3.3/16")
Weight	16 kg (59.5 lbs)
Magnet power	860 Kg.
Input supply voltage	220 V

COMPONENTS CONTENT

1. Packing case	1 No.
2. Cooling Bottle	1 No.
3. Safety Belt	1 No.
4. 2,5 mm Allen Wrench	1 No.
5. 5,0 mm Allen Wrench	1 No.
6. 6,0 mm Allen Wrench	1 No.
7. Instruction Manual	1 No.
8. Magnetic Drill Machine	1 No.
9. MT 3x19.05 Arbor	1 No.
10. Pilot Pin 6x50	1 No.
11. Pilot Pin 8x50	1 No.
12. Taper Drift	1 No.

UNDERSTANDING SAFETY SYMBOLS



DANGER : The possibility of suffering harm , injury or even death if the situation is not avoided during operation of the machine



WARNING : A statement or event that warns of something or that serves as a cautionary example while using the machine



CAUTION : Care taken to avoid danger or mistakes during operation of the machine



NOTE : A brief record of points or ideas written down as an aid to memory while using the machine

When using magnetic drilling machines please follow the general safety instructions for electric power tools.

Please read the manual	Use eye protection	Use ear protection	Use safety helmet
Use safety gloves	Wear appropriate clothing	Disconnect before opening	Use safety chain
Warning for electrical shock	Dangerous environment	Don't use in wet places	Pacemaker warning

WARNING: THIS APPLIANCE MUST BE EARTHED.

1. Always secure the machine with the supplied safety chain before starting to operate, this is to protect the user in case of power failure or breaking loose of the magnet while in use.
2. Always wear safety goggles, gloves and ear plugs.
3. Disconnect from the power source when changing cutters or working on the machine.
4. Always ensure cutter retaining screws are secure – they sometimes vibrate loose in use.
5. Regularly clean the work area and machine., remove swarf and dirt, paying particular attention to the underside of the magnet.
6. With a gloved hand, after switching off the power, remove any swarf which might have gathered around the cutter and arbor before proceeding to the next hole.
7. Remove tie, rings, watches and any loose adornments which might entangle with the rotating parts of the machine.
8. Should the cutter get stuck in the workpiece, stop the motor immediately to prevent personal injury. Disconnect from the power source and push and pull the arbor by hand. **DO NOT ATTEMPT TO FREE THE CUTTER BY SWITCHING THE MOTOR ON AND OFF.**
9. If the machine is accidentally dropped, always thoroughly examine the machine for signs of damage and check that it functions correctly before trying to drill a hole.
10. Regularly inspect the machine and check the nuts and screws are tight.
11. Always ensure when using the machine in an inverted position use special cutting paste or cutting spray which is specially designed for inverted position drilling.
12. Use only spare parts advised by your dealer for magnetic drilling machines.
13. Use the magnetic drilling unit on a clean and flat surface only, to prevent the machine breaking out because of poor clamping force.
14. If you discover any irregularity on machine cables immediately bring the machine to a recognized dealer for a repair or maintenance service.

WARNING : DO NOT USE YOUR MAGNETIC DRILL ON THE SAME STRUCTURE WHEN ARC WELDING IS IN PROGRESS. D.C. CURRENT WILL EARTH BACK THROUGH THE MAGNET AND CAUSE IRREPARABLE DAMAGE.

SAFETY INSTRUCTIONS



WARNING

It is mandatory to read and follow all the safety norms, regulations and instructions given in this Guide before you operate the machine to avoid unwanted and fatal accidents. Follow the mentioned workplace safety measures in the guide strictly to ensure your safety against electric shocks or injuries.

SELF PROTECTION

The machine operators must start their work only after wearing protective gears like eyeglasses, ear muffs, and insulated shoes tightened to the legs ensuring comfortable movement.

Never operate the machine using your feet or remove the slug without wearing the gloves. Never work towards the maintenance of the circuit board if you haven't followed all the rules mentioned above.

MANDATORY RULES FOR THE WORK PLACE

1. Say no to a messy work environment completely. Keep yourself protected against fatal accidents by keeping the area clean.
2. In case the floor is wet, stop the usage of the drill machine immediately. You will expose yourself to the risk of shock if you don't.
3. Only when the surroundings around are brightly lit, use the machine instead of a dark environment.
4. You should not never place flammable material near the machine or avoid using the drill machine in the presence of anything flammable. The drill machine tends to produce sparks in the process of working, which may cause fire.
5. Children should never be allowed near the drill machine, especially when it is being operated.
6. Nobody should be in the area where the drill machine is being used by the Operator.

MANDATORY RULES TO ENSURE SAFETY

1. Before starting the drill machine, make sure you inspect the condition of the power cord and the plug. Replace them immediately if you see any damage.
2. The power supply should always be in sync with what the equipment requires. Hence, ensure the same while making sure that safety measures for grounding and leakage are made available.
3. Study this manual well to understand the do's and don'ts of the drilling tools. They should be used strictly according to the size specified. The material of the drilling workpiece comes with a magnetized absorption and works better on a smooth surface. Double check that its thickness ranges between 10mm-75mm, without the 0.5mm thickness of Iron scrap and the presence of paint, granular impurities and any other foreign particles should be avoided.
4. If the thickness of the drilling machine is less than 10mm, you must ensure that it is well-supported by iron plates right at the bottom that come with a thickness higher than 10mm. The supporting iron plate must have a base area greater than the drilling machine's area of the magnetic base if you need to improvise the reliability of the capability of the magnetic base's absorption. In case you opt for a supporting iron plate which is thinner than the requirement, you will notice the drilling machine magnet becoming loose in the process of absorption that may lead to unwanted and fatal accidents.
5. Don't press the drill machine too hard as that may lead to an overload, which tends to shorten the life of the magnetic drill. When in use, be extremely attentive to the condition of the magnetic absorption of the drill. Stop using the drill immediately if you notice any instability in the magnetic absorption.
6. Whenever the drill starts to operate or shuts down, ensure that the operating sequence of the motor and magnetic switch has been complied.
7. Do not continuously operate the magnetic base with a full load as that will cast a strong effect negatively on the life of the magnetic base. It may also get heated up to an extent that it may catch fire. Never touch the magnetic base, especially when it is extremely hot as that will cause a serious burn. Turn off the switch and unplug immediately once you stop using the magnetic base.
8. Do not use drilling machine for not more than a total duration of 30

minutes at a stretch. If done otherwise, it will lead to extreme heat getting generated that will result in a fire or explosion. Switch off the motor when it is not in use.

9. Add a certain amount of coolant to the equipment whenever you replace the drill. In case you notice a blockage, switch off the motor immediately. However, you must leave the magnetic base power on. The logic behind this process is that in case you shut down the power supply of the magnetic base directly, it may result in the operator suffering from injuries. It will also harm the motor because of the sudden loss of magnetic force of the magnetic base.
10. Whenever the magnetic drilling machine is in use and is suspended either in a vertical or a horizontal position, you must get it fixed with a device that gets attached to the equipment so that it doesn't come down falling caused by the sudden loss of power of the magnetic base. When you choose to drill in an upside-down position, always opt for cutting paste or cutting spray a cooling method that is reasonable. Say a frank NO to the option of liquid cooling method as liquid will easily infiltrate into the equipment and result in leakage of electricity. Instead of liquid cooling method, choose cutting paste or spray coolant.
11. Only use genuine spare parts and tools as it comes with guaranteed usage safety.
12. Do not remove the drill if the spindle and the drill are in continuous motion. Unplug the drill from the main power supply to change its gear and never touch it with your bare hands.
13. Even when the equipment stops working, never use your bare hands to remove the slug after the drilling process as it is very hot.
14. While using the magnetic drill on a particular workpiece, do not do the process of welding on the same work piece.
15. Use the handle function of the drilling machine to move it from one place to another instead of pulling the power cable.
16. Switch off the main power supply and unplug the drilling machine after the usage. If this is not done and the spindle and the tool continue to rotate, then do not let the operator remove the drill and replace the gear with his bare hands. Make sure you practice this to avoid injuries.
17. The generation of the magnetic field affects devices such as watches, mobile phones and pacemaker installed to regulate the heartbeat. Make sure that the operator takes off the watch and keeps off the mobile phone before operating the drilling machine and doesn't have a pacemaker installed in him.

CLEANING AND MAINTENANCE

1. Keep a close check on the bolt of the magnetic drill. It should not be loose and the gap in the spindle should not be too large. The power cable of the drill should be in a good condition. You must make sure that the machine is maintained well.
2. Inspect the carbon brush and change it immediately if you notice that it is worn out.
3. The lubricating grease in the Gear Box should be changed by a professional once you have used the drill for three months. Inspect well once the professional finishes to double check that all the parts have been fully lubricated.
4. It is always the after-sales service department or the designated dealer who cater to the maintenance of the drill machine.
5. The operator must clean the magnetic drill after finishing the work, scrub the side where the drill slides while working and apply lubricating oil on the drill for the machine to last longer.
6. Whenever you indulge in the process of cleaning the Drill with compressed air, you must wear safety goggles and protective gloves to protect yourself and the other people around you at the workstation.
7. Switch the machine off and unplug it from the main power socket before you start the process of maintenance and cleaning.

When it comes to the process of maintenance, inspection and repair pertaining to their electrical aspects, only a qualified electrician must be contacted to cater to the task. The qualifications of these electricians change according to their respective countries. They must follow the effective rules put in place when it comes to processing, inspection and the maintenance of a Circuit Board in order to avoid accidents.

ENVIRONMENTAL PROTECTION AND WASTE DISPOSAL

1. Disposal of the old electrical equipment: Make sure you process the product in accordance with EC Directive 2002/96/EC-WEEE, also known as Waste Electrical and Electronic Equipment. In case of doubts or queries, contact the Department of Waste Disposal.
2. Disposal of grease: Follow the instructions given by the lubricant's manufacturer.

OPTIONAL TOOLS & ACCESSORIES

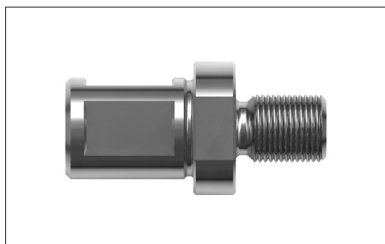

Weldon Drill Chuck Adaptor



Weldon Tapping Adaptor



Drill Chuck



Weldon Counter Sink



MT 3 Arbour

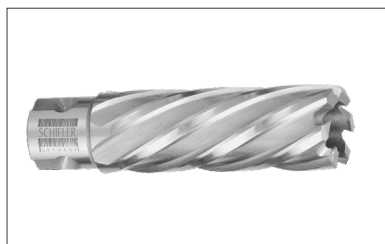

Core Drill



Pilot Pin



Taper Drift

OPERATING MANUAL

5.1 How to mount tools or adapters in a Weldon arbor?

- 1) Make sure the machine is disconnected from the power supply.
- 2) Put the center pilot in the cutter hole.
- 3) Put the cutter or adapter in the arbor, making sure the flat sides are exactly in front of the arbor retaining screws.



- 4) Tighten the retaining screws.
- 5) Check if the center pilot can move inside the cutter (up and down).

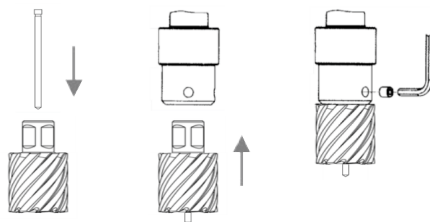

5.2 Drilling with Core Drills

- 1 Place the machine at the desired position



CAUTION : For 100% magnet clamping force you need at least 10 mm of steel. Coatings, paintings and dirt between magnet and workpiece will affect clamping force.

- 2 Switch on the magnet.



- 3 Ensure that the magnetic drilling unit is secure on the working piece.
- 4 Fill the arbor with lubrication/cutting oil in the special meant holes. Always use cutting oil from your dealer.
- 5 Start the motor by pressing the green motor start button (I).



- 6 Start bringing the cutter to the workpiece but handle with care and do not apply too much pressure. The cutter has to find its way in to the material by itself. After 2 mm, the groove of the cut will help the cutter maintain its place and you can increase the power. Still it is not necessary to use a lot of pressure. Too much pressure will cause damage and breakage.
- 7 After the cut is finished the slug will automatically be ejected from the cutter, switch the machine off by pushing the red button(0).
- 8 If the slug gets stuck in the cutter, move the machine to a flat surface. Switch on the magnet and gently bring the cutter down in contact with the surface. This usually allows a slug to straighten and to eject.

WARNING: THE SLUG WILL BE EJECTED AND IS VERY HOT

5.3 Drilling with twist drills

There are several accessories available to be able to use twist drills with your magnetic drill.

- Adapter 19 mm Weldon - 1/2" x 20 UNF
- Adapter 19 mm Weldon – B16 taper connection
- Adapter 19 mm Weldon – B18 taper connection



Weldon Drill Chuck Adaptor



Drill Chuck



Taper shank twist drill

These adaptors will allow you to attach a drill chuck on to the hole cutter arbor.

Also twist drills with a direct Weldon connection are available (ranging from $\varnothing 6 - \varnothing 12$ mm)

- 1 Place the machine at the desired position
- 2 Switch on the magnet



- 3 Ensure that the magnetic drilling unit is secure on the working piece.
- 4 Apply cutting oil to the twist drill and workpiece. Always use cutting oil from your dealer.
- 5 Start the motor by pressing the green motor start button.



- 6 Start bringing the twist drill to the workpiece but handle with care and do not apply too much pressure. The drill has to find its way in to the material by itself. It is not necessary to use a lot of pressure. Too much pressure will cause damage and breakage.
- 7 After the cutting is finished switch the machine off by pushing the red button.

5.4 SPEED SELECTION

It is recommend to run the machine for diameter up to 32mm on Speed 1 (450 min⁻¹) and for diameter above 32mm Speed 2 (250 min⁻¹) is recommended as show.

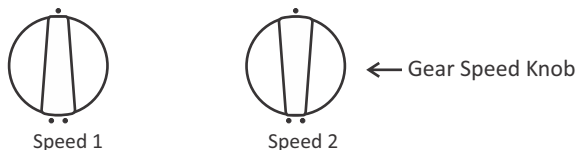

In order to select the desired gear speed follow diagram below.

Warning:

Switch off the machine before changing the gear knob.

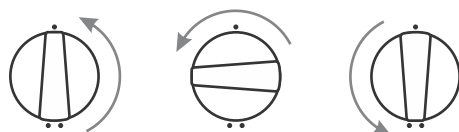

It might be possible that while shifting the gears it could have stuck with the already selected speed gear, adjust spindle of the machine by moving it clockwise and anti clockwise direction simultaneously moving the speed knob.



5.5 REAMING/COUNTER-SINKING

1. You can make use of the machine for the process of Reaming or Counter-sinking too, considering the machine's wide range of speed availability to operate.
2. In this process, always observe the limitations stated in the technical data for the tools to be made use of.

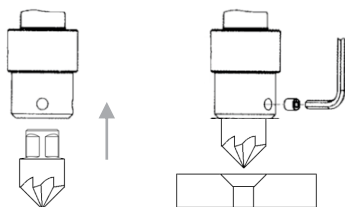

5.6 Pipe Drilling Magnet Base

By combining Magswitch's patent-pending rotating magnet technology and Schifler's lightest unit yet, we have created a tool that is capable of quickly and safely drilling on contoured and flat surfaces.

Magswitch LAY magnets allow for a much more efficient field on thinner material, allowing more consistent tip forces.

The attachment force generated by the magnet depends on various factors.

- Thickness of the material the magnet is placed on;
- Material Grade;
- Paint or coating of the material the magnet is placed on;
- Metal chips, oil or other dirt under the magnet.

As guideline on regular construction steel :

Minimal required material thickness :	3,5mm (1/8")
Ful saturation as from material thickness	12,5 mm (1/2")

Make sure that the two magnet arrays attach tightly to the work piece before turning on the motor unit of the magnetic drilling machine.

Always use the safety chain. Drilling above your head is extremely dangerous and is not recommended.

The Magswitch

The two handles on the Magswitch arrays need to be rotated the full 180 degrees to be considered fully ON or OFF

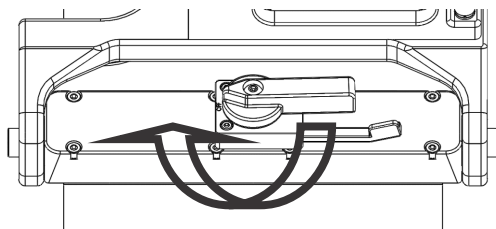

In order to operate properly, the machine **MUST** be turned ON following the procedure as described below.

ACTIVATING THE MAGNETS

Connect the machine to the mains/work piece. To activate the magnets, rotate the ratcheting action handle the full 180-degree rotation.

TURNING THE MOTOR ON AND OFF

To turn the motor ON, press the green button with marking "I". To switch the motor OFF, press the red button with marking "O".

SWC 50 PD Motor complete / Antriebseinheit

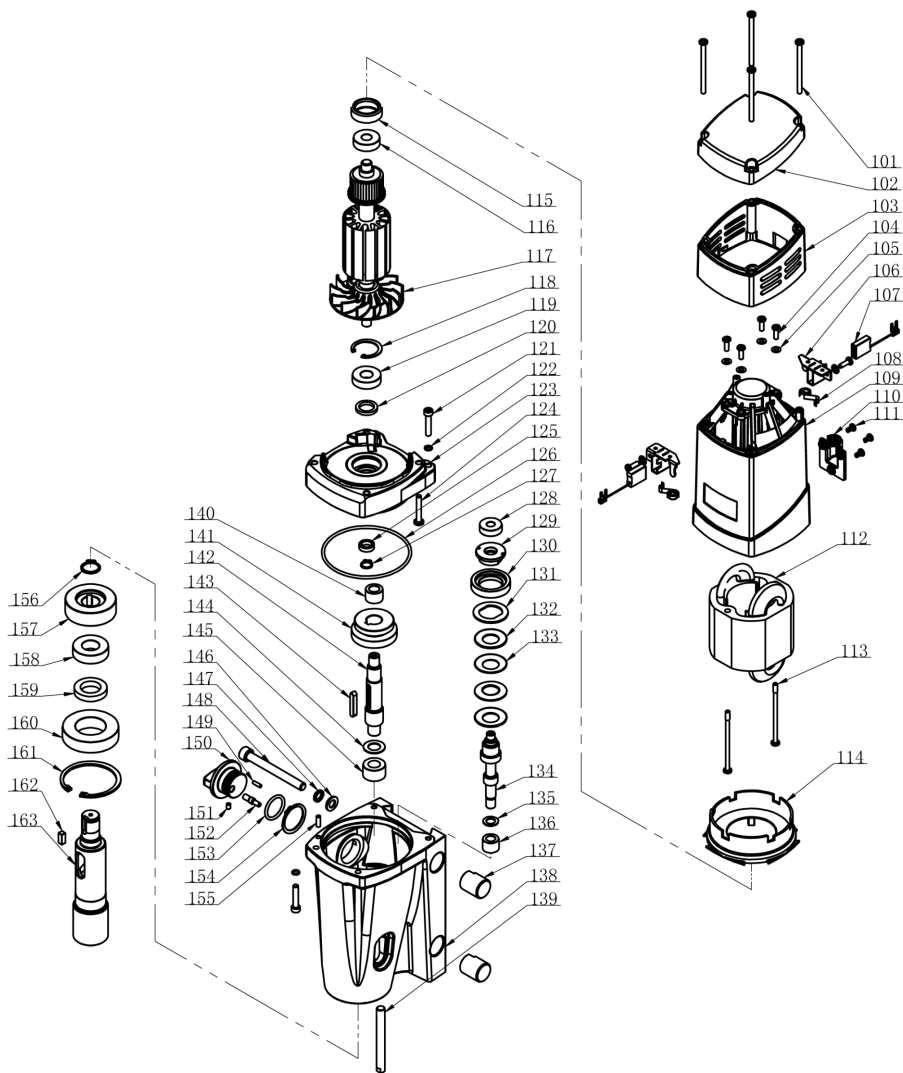

SWC 50 PD Motor complete / Antriebseinheit

Part no.	Article	Article	Description	Pcs
101	0709311695492	Cross Recessed Tapping Screw	ST4.2x60	4
102	0709311703913	Motor Cover	50-86x86x45	1
103	0709311695508	Motor Inlet cover	50-88x88x61	1
104	0709311695515	Screws	M4x12	6
105	0709311695522	spring washer	M4	4
106	0709311695539	Carbon Brush Holder	15.8x6.2x20	2
107	0709311695546	Carbon Brush	15.8x20x6.2 220V	1
108	0709311703920	Scroll Spring	5x0.3	2
109	0709311695553	Motor Housing	50-101x96x167	1
110	0709311695560	inlet cover	34x40x13	1
111	0709311695577	screws	ST3.5x6.5	3
112	0709311703937	Field Coil	1500W 220V	1
113	0709311695584	Screws	ST4.2x70	2
114	0709311695591	Air Guide	50-ø87x43	1
115	0709311695607	Bearing Sleeve	6000	1
116	0709311695614	Ball Bearing	6000 ZZ	1
117	0709311695621	Armature	1500W 220V	1
118	0709311704248	circlip	ø28	1
119	0709311704064	Ball Bearing	6001 ZZ	1
120	0709311704071	Seal	ø15xø21x3	1
121	0709311704088	Hex Screw	M5x25	4
122	0709311704279	Spring Washer	M5	4
123	0709311704095	Gear Box Cover	50-106x96x35	1
124	0709311704101	Screws	ST4.8x30	4
125	0709311704118	Rotor seal ring	ø10xø15x4.5	1
126	0709311704255	O' Ring	84xø2	1
127	0709311704125	Shaft retainer ring	ø10	1
128	0709311704132	Ball Bearing	608 ZZ	1
129	0709311704149	Copper Sleeve	ø29x9.5 M16x1.5	1
130	0709311704286	clutch helical gear	Z44m0.8h8	1
131	0709311704156	Copper Gasket	ø33x1.5	1
132	0709311704163	Disc Spring	ø31.5x16.2x1.25	Complete Set
133	0709311704170	Disc Spring	ø31.5x16.8x0.8	1
134	0709311704262	Transmission Gear Shaft #1	Z17m1h7/Z10m1h9	1
135	0709311704187	Gasket	ø15xø9.2x1	1
136	0709311704194	Needle Bearing	9/12	1
	0709311704200	Block	ø20x24	2
138	0709311704293	Gear Casing	50-116x96x164	1
139	0709311704217	Lever	M8x90	1
140	0709311704224	Needle Bearing	10/12	1
141	0709311704231	Double Gear	Z34m1h6.3/Z41m1h8	1
142	0709311707591	Transmission Gear Shaft # 2	Z13m1h16.5	1
143	0709311707607	Key	A5x5x28	1
144	0709311707614	Gasket	ø21xø12.2x1	1
145	0709311707621	Needle Bearing	4901	1
146	0709311707638	washer	M8	2
147	0709311707645	spring washer	M8	2
148	0709311707652	Hex Screw 10.9 Grade	M8x75	2
149	0709311707669	Cylindrical Pin	ø3x10	1
150	0709311707676	Gear Shift Knob	ø39.6x31	1
151	0709311707683	Plunger	4	1
152	0709311707690	Shift Lever	ø6x21.5 M5	1
153	0709311707706	O' Ring	ø21.2xø2.65	1
154	0709311707713	Shaft retainer Circlip	26	1
155	0709311707720	Cylindrical Pin	ø4x12	1
156	0709311707737	shaft retainer ring	ø17	1
157	0709311707744	Main Shaft Gear	Z45m1h15	1
158	0709311707751	Ball Bearing	6003 2RS	1
159	0709311707768	Inner Frame Rotary Lip Seal	ø20xø32x6	1
160	0709311707775	Ball Bearing	6006 ZZ	1
161	0709311707782	Circlip	ø55	1
162	0709311707799	Key	B5x5x12	1
163	0709311707805	Spindle Drive Shaft	ø34x145 MT3	1

SWC 50 PD Magnetic frame / Magnetbohrständer

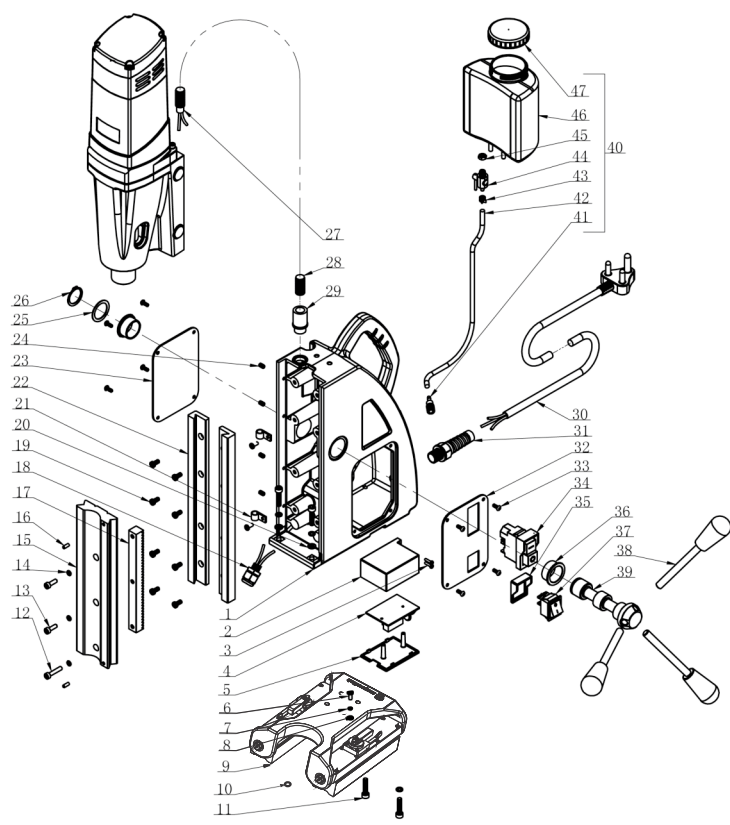

SWC 50 PD Circuit Diagram / Schaltplan

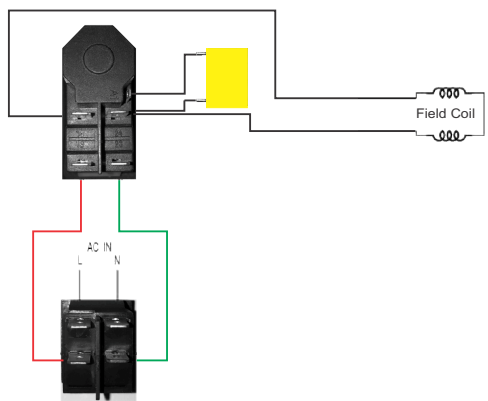

SWC 50 PD Magnetic frame / Magnetbohrständer

Part no.	Article	Article	Description	Pcs
1	0709311695027	Main Body	50-344x215x94	1
2	0709311695034	PCB Box	66x52x30.5	1
3	0709311695041	screws	M3x12	2
4	0709311695058	PCB	220V	1
5	0709311695065	PCB COVER	66x52x24	1
6	0709311695072	screws	M4x10	3
7	0709311695089	Spring Washer	M4	1
8	0709311695096	Lock Washer	4	3
9	0709311710119	Magnet	198x97x47 220V	1
10	0709311695119	Spring Washer	M6	4
11	0709311695126	Hex Screw	M6x25	4
12	0709311695133	hex Screw	M5x25	1
13	0709311695140	Hex Screw	M5x15	2
14	0709311695157	spring washer	M5	3
15	0709311695164	Slide	20.5x250	1
16	0709311695171	Grub Screw	M4x10-10.9	2
17	0709311695188	Rack	15x15x170 m1.5	1
18	0709311695195	Cable Head	MA12-08	1
19	0709311695201	Hex Screw	M5x10	8
20	0709311695218	Washer	M6	2
21	0709311695225	R- Clip	6.4mm	2
22	0709311695232	Slide Guide	16x27x285	2
23	0709311695249	Panel	90x130x2	1
24	0709311695256	Hex Screw	M5x8	4
25	0709311695263	Gasket	ø25xø33x1	1
26	0709311695270	Shaft Retainer ring	ø25	1
27	0709311695287	Elbow Cable Connector	220V 10A 1mm ²	0.9
28	0709311695294	Hose	ø13	0.3
29	0709311695300	Connector	ZT-M16-AD13	1
30	0709311695317	Main Power Cable	250V 16A 1.5mm ² 3.5m	1
31	0709311695324	Torsion Joint	MA16-P-10	1
32	0709311695331	Control Panel	90x130x2	1
33	0709311695348	Hex Screw	M4x10	8
34	0709311695355	Motor Switch	220 V	1
35	0709311695362	Switch Cover	37x30.5x12	1
36	0709311695379	Feed Bush	ø35xø25x15	2
37	0709311695386	Magnet Switch	KDC	1
38	0709311695393	Feeding Handle	M10x150	3
39	0709311695409	Feeding Gear Shaft	37x118 Z14m1.5	1
40	0709311695416	Coolant Bottle	600ml	1
41	0709311695423	Coolant Nozzle	4mm	1
42	0709311695430	PU Tube	6x4	0.3
43	0709311695447	Hoop	ø6	1
44	0709311695454	Aluminium Valve	ø15.5x37-90	1
45	0709311695461	Hex Nut	8x1	1
46	0709311695478	Coolant Container	600ml	1
47	0709311695485	Coolant Bottle Lid	ø58x12	1



6. Handy Tips

TIP: Do not use your magnetic drill on the same structure when ARC welding is in progress. D.C. current will earth back through the magnet and cause irreparable damage.

TIP: It is recommended that machine is laid to rest every 30 minutes in order to permit grease to run across the gear box.

TIP: When using models with gear and variable speed always select a setting with low transmission ratio and high motor speed, if possible.

TIP: During drilling it is recommended after a certain depth the cutter should be pulled up on free load in order to permit grease to run across the gear box.

TIP: For 100% magnet clamping force you need at least 10 mm of steel. Coatings, paintings and dirt between magnet and workpiece will affect clamping force.

TIP: Most situations which cause problems or question marks have already occurred for other users. Contact Schifler or your dealer to see if a solution exists for your situation. (example: for drilling into non-magnetic material with your magnetic drill, a special vacuum system has been designed).



WARNING: This appliance must be earthed.

WARNING: After drilling the slug will be ejected and is very hot.

WARNING: When drilling in inverted position, cutting oil can enter the motor and can cause irreparable damage.

WARNING: When drilling in inverted position, metal swarf can enter the motor. This can cause irreparable damage and can cause electrical shocks.

WARNING: Steel plates of less than 10 mm thickness, coatings, paints and dirt between magnet and workpiece can affect clamping force and create a possible dangerous situation. Always make sure your magnetic drill is fastened with the supplied safety chain and make sure your machine is sufficient attached to the workpiece to start drilling.



TROUBLESHOOTING

1. If the type of error that you face revolves around the Motor not starting even after pressing the ON/OFF button or the motor tends to stop while it is functioning, following can be the possible causes along with the remedies:
 - a. The plug isn't properly inserted into the socket. Just re-insert the plug.
 - b. The Circuit Breaker has been switched off by accident. Switch it on.
 - c. The torque cut-off has been triggered. You just have to switch the machine off for a few seconds and then switch it on.
 - d. You have missed selecting the direction of rotation. Click on select.
 - e. You haven't switched on the magnetic clamp. Switch it on.
 - f. The machine is over-heated because of which the internal safety switch of the machine is switching it off. Let the machine cool down for some time and then switch it on.
2. If the type of error that you face revolves around the Circuit Breaker tripping in the power distributor, following can be the possible causes along with the remedies:
 - a. The machine has some defective parts. Immediately contact the Customer Service.
 - b. Plenty of appliances have been connected to the same power circuit, resulting in the tripping. Unplug a few of those appliances.
3. If the type of error that you face revolves around the Magnetic clamp not functioning to its best capability, following can be the possible causes along with the remedies:
 - a. You have not switched on the magnet. Switch it on.
 - b. The surface where the machine is placed is not magnetic enough. Change the placement and use a suitable base.
4. If the type of error that you face revolves around the lubrication system not functioning to its best capability or failing to function at all, following can be the possible causes along with the remedies:
 - a. The lubricant is over. Pour the required amount of lubricant into the machine.
 - b. The connecting nipple has gotten clogged. Do a deep cleaning of the tank and the nipple.
 - c. The lubricant tap is jammed or has gotten closed. Open the tap.

Contact the Customer Service immediately if the steps and remedies described above do not solve your problem.

WARRANTY

The warranty period for Schifler Magnetic Drills equipment is 6 months as of the date of purchase.

Damages due to wear and tear, overload or improper handling of the machine are excluded from warranty. Damages that are due to fault in material or defect in fabrication will be remedied free of cost by compensation delivery or repair.

Claims for damages cannot be derived from this warranty.

Please fill out the warranty or add the purchase receipt.

MACHINE TYPE :

MACHINE NUMBER :

DATE OF PURCHASE :

STAMP/SIGNATURE AUTHORISED DEALERS :

ERROR DESCRIPTION:



European Union

Schiffler Werkzeuge & Co.
Bahnhofstraße. 8, 30159, Hannover, GERMANY
Tel.: +49 (0) 511 93639 421
Fax.: +49 (0) 511 93639 300
Email: info@schiffler.de

Asia Pacific

Schiffler Werkzeuge & Co.
B-24, 1st Floor, Street No.9, Anand Parbat
Industrial Area, Delhi-110005, INDIA
Telefon : 011-41044650
Email: india@schiffler.de

Middle East

Schiffler Werkzeuge Middle East FZC
UAQ Free Trade Zone, P.O. Box : 7073,
Umm Al Quwain, U.A.E.
Telefon : +971-568965572
Email : uae@schiffler.de

www.schiffler.de