

DE4

User Manual

World Leading FPGA Based Products and Design Services

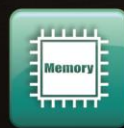
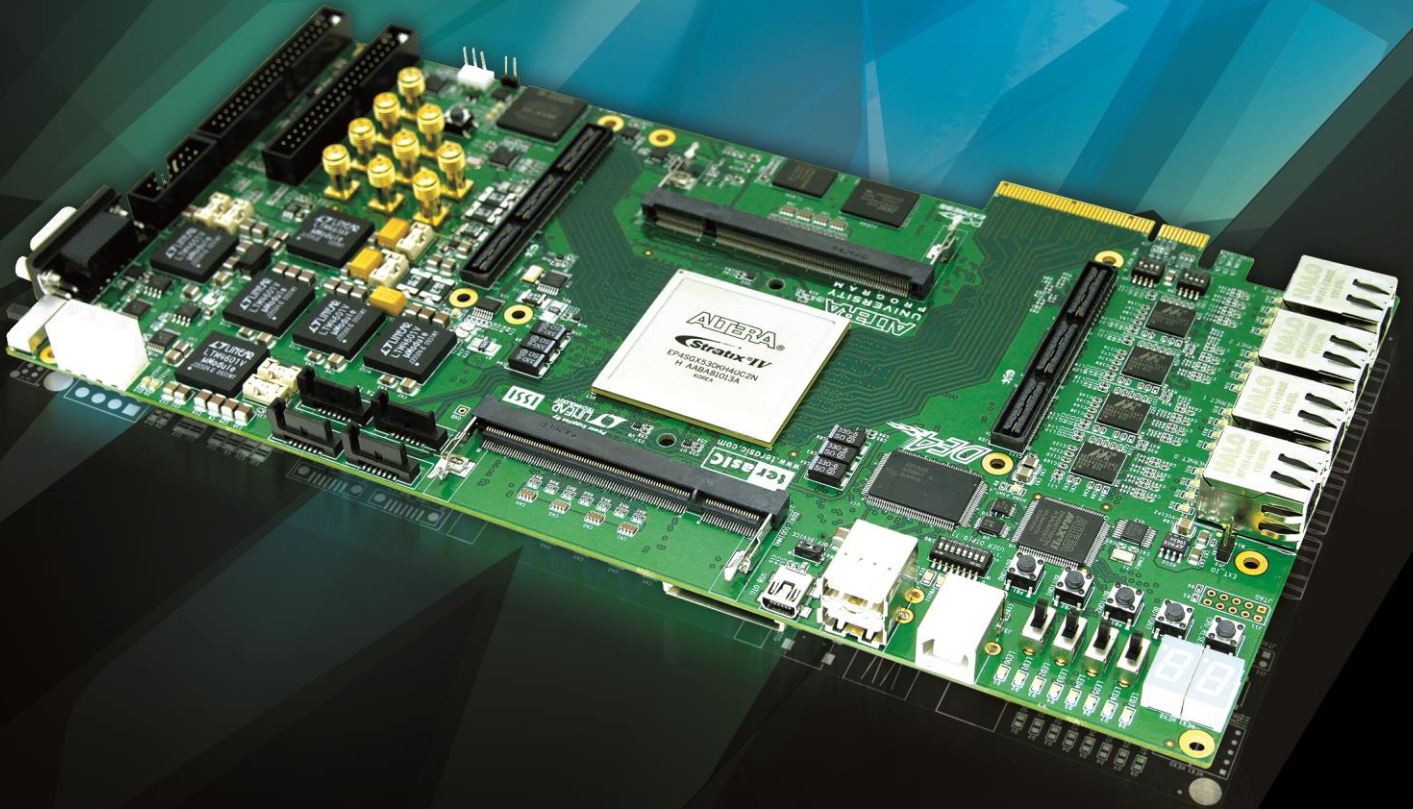

CHAPTER 1	<i>OVERVIEW</i>	4
1.1	GENERAL DESCRIPTION	4
1.2	KEY FEATURES.....	5
1.3	BOARD OVERVIEW	6
1.4	BLOCK DIAGRAM.....	7
CHAPTER 2	<i>USING THE DE4 BOARD</i>	13
2.1	CONFIGURATION OPTIONS	13
2.2	SETUP ELEMENTS.....	20
2.3	STATUS ELEMENTS.....	21
2.4	GENERAL USER INPUT/OUTPUT	22
2.5	HIGH-SPEED MEZZANINE CARDS.....	26
2.6	GPIO EXPANSION HEADERS	37
2.7	DDR2 SO-DIMM.....	41
2.8	USB OTG.....	49
2.9	SD CARD	52
2.10	CLOCK CIRCUITRY	53
2.11	PCI EXPRESS.....	57
2.12	GIGABIT ETHERNET (GIGE)	60
2.13	SERIAL ATA (SATA)	63
2.14	RS-232 SERIAL PORT	66
2.15	FLASH MEMORY	66
2.16	SSRAM MEMORY	68
2.17	I2C SERIAL EEPROM	70
2.18	TEMPERATURE SENSOR	70
2.19	POWER.....	71
CHAPTER 3	<i>CONTROL PANEL</i>	74
3.1	CONTROL PANEL SETUP	74
3.2	CONTROLLING THE LEDs AND 7-SEGMENT DISPLAYS	78
3.3	SWITCH/BUTTON	80
3.4	MEMORY CONTROLLER.....	81

3.5 USB2.0 OTG	84
3.6 SD CARD	85
3.7 TEMPERATURE MONITOR	86
3.8 POWER	87
3.9 PLL	88
3.10 SATA	89
3.11 HSMC	90
3.12 FAN	91
CHAPTER 4 DE4 SYSTEM BUILDER.....	93
4.1 INTRODUCTION	93
4.2 GENERAL DESIGN FLOW	94
4.3 USING DE4 SYSTEM BUILDER	95
CHAPTER 5 EXAMPLES OF ADVANCED DEMONSTRATION.....	106
5.1 USB HOST	106
5.2 USB DEVICE	115
5.3 ETHERNET – SIMPLE SOCKET SERVER.....	119
5.4 SD CARD READER	127
5.5 DDR2 SDRAM	131
5.6 EXTERNAL CLOCK GENERATOR	135
5.7 POWER MEASUREMENT	142
5.8 WEB SERVER.....	146
5.9 SERIAL ATA (SATA)	155
5.10 HIGH-SPEED MEZZANINE CARD (HSMC).....	156
CHAPTER 6 PCI EXPRESS REFERENCE DESIGN.....	159
6.1 PCI EXPRESS SYSTEM INFRASTRUCTURE.....	159
6.2 FPGA PCI EXPRESS SYSTEM DESIGN	160
6.3 PC PCI EXPRESS SYSTEM DESIGN	164
6.4 FUNDAMENTAL COMMUNICATION.....	174
6.5 EXAMPLE 2: IMAGE PROCESS APPLICATION	179
ADDITIONAL INFORMATION.....	185

Chapter 1

Overview

This chapter provides an overview of the DE4 Development Board and details the components and features of the board.

1.1 General Description

The DE4 Development Board provides the ideal hardware platform for system designs that demand high-performance, serial connectivity, and advanced memory interfacing. Developed specifically to address the rapidly evolving requirements in many end markets for greater bandwidth, improved jitter performance, and lower power consumption. The DE4 is powered by the Stratix® IV GX device and supported by industry-standard peripherals, connectors and interfaces that offer a rich set of features that is suitable for a wide range of compute-intensive applications.

The advantages of the Stratix® IV GX FPGA platform with integrated transceivers have allowed the DE4 to fully compliant with version 2.0 of the PCI Express standard. This will accelerate mainstream development of PCI Express-based applications enabling customers to deploy designs for a broad range of high-speed connectivity applications. The DE4 coupled with serial ATA (SATA) interfaces, offer a solution for developing storage applications. The DE4 delivers fully tested and supported connectivity targeted reference design that integrates built-in blocks for PCI Express, SATA transceiver verification testing, and Gigabit Ethernet protocol.

The DE4 is supported by multiple reference designs and two High-Speed Mezzanine Card (HSMC) connectors that allow scaling and customization with mezzanine daughter cards. For large-scale ASIC prototype development, it can be established by a cable connecting to multiple DE4/FPGA boards through the HSMC connectors.

It is highly recommended that users read the *DE4 Getting Started Guide.pdf* before using the DE4

board.

1.2 Key Features

The following hardware is implemented on the DE4 board:

- Featured device
 - Altera Stratix® IV GX FPGA (EP4SGX230C2/EP4SGX530C2)
- Configuration status and set-up elements
 - Built-in USB Blaster circuit for programming
 - Fast passive parallel (FPP) configuration via MAX II CPLD and flash memory
 - Three External Programmable PLL timing chip
- Component and interfaces
 - Four Gigabit Ethernet (GigE) with RJ-45 connector
 - Two host and two device Serial ATA (SATA II) ports
 - Two HSMC connectors
 - Two 40-pin expansion headers
 - PCI Express 2.0 (x8 lane) connector
- Memory
 - DDR2 SO-DIMM socket
 - FLASH
 - SSRAM
 - SD Card socket
 - I2C EEPROM
- General user input/output:
 - 8 LEDs
 - 4 push-buttons and 4 slide switches
 - 8-position DIP switch
 - 2 seven-segment displays
- Clock system
 - On-board clock oscillators: 50MHz and 100MHz

- SMA connectors for external clock input
- SMA connectors for clock output
- Other interfaces
 - USB 2.0 high-speed host/device OTG
 - Current sensor for FPGA current measurement
 - Temperature sensor

1.3 Board Overview

Figure 1–1 and Figure 1–2 is the top and bottom view of the DE4 board. It depicts the layout of the board and indicates the location of the connectors and key components. Users can refer to this figure for relative location when the connectors and key components are introduced in the following chapters.

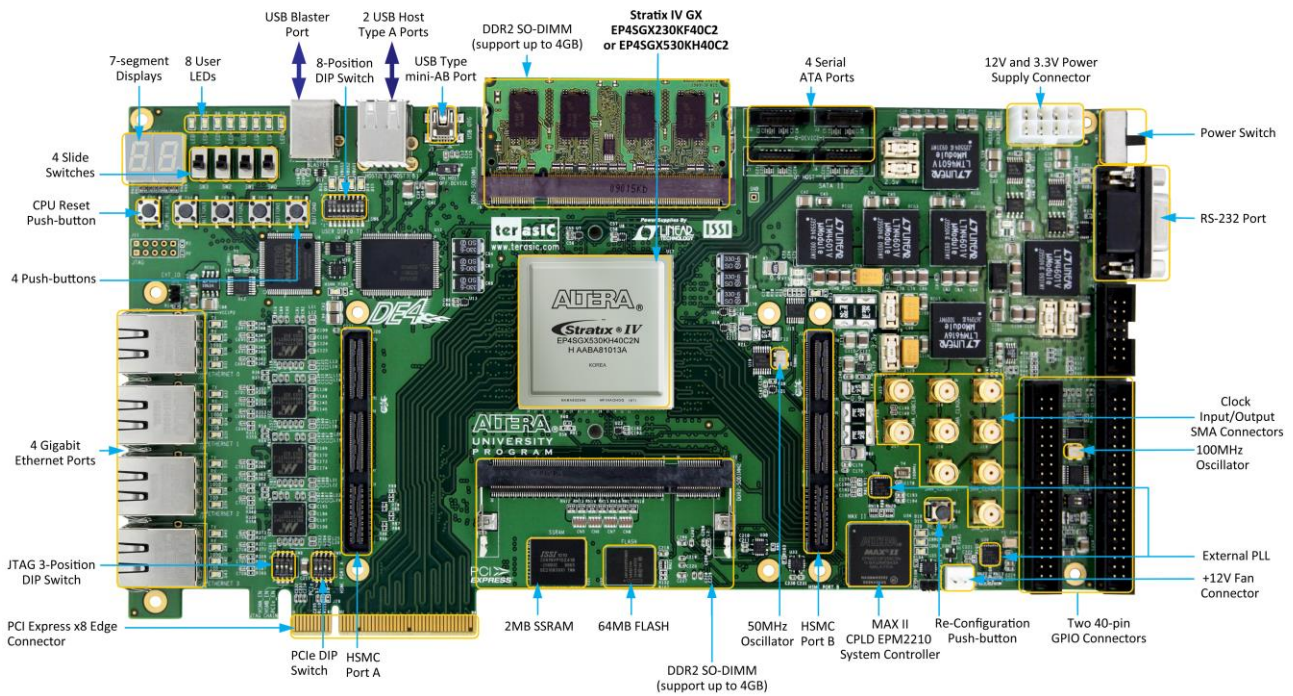

Figure 1–1 The DE4 board (Top view)

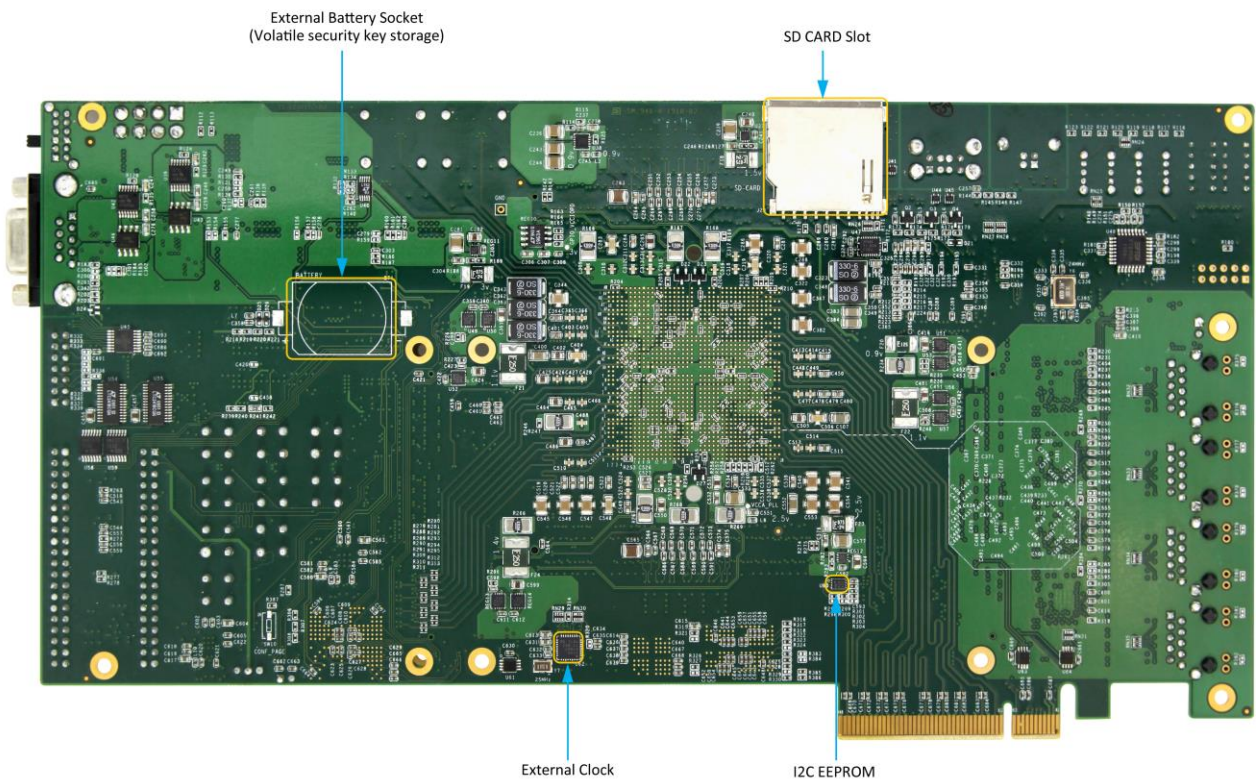

Figure 1–2 The DE4 board (Bottom view)

1.4 Block Diagram

Figure 1–3 shows the block diagram of the DE4 board. To provide maximum flexibility for the users, all key components are connected with the Stratix IV GX FPGA device. Thus, users can configure the FPGA to implement any system design.

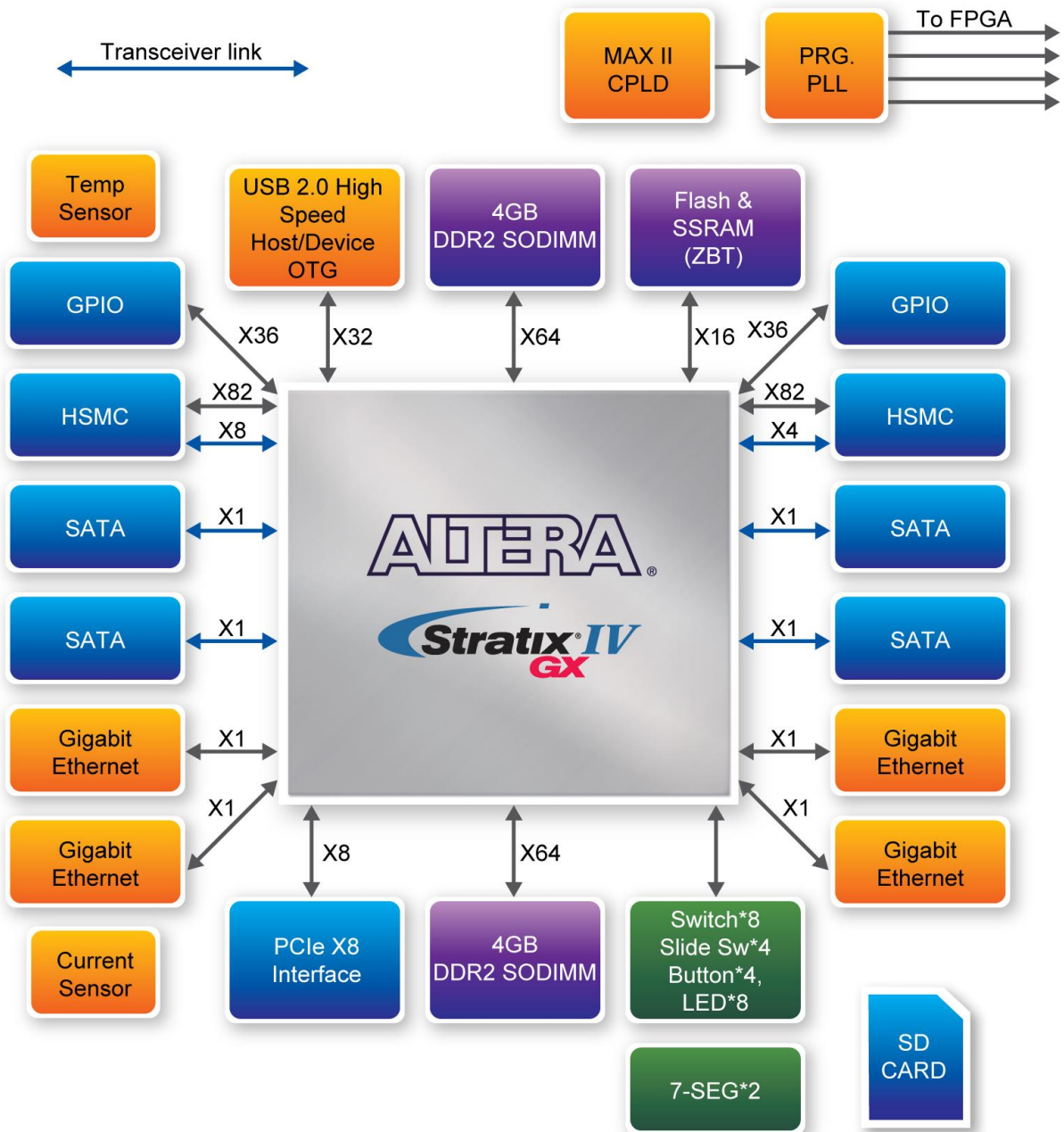

Figure 1–3 Block diagram of the DE4 board

Below is more detailed information regarding the blocks in **Figure 1–3**.

Stratix IV GX FPGA

- EP4SGX230C2
 - 228,000 logic elements (LEs)
 - 17,133 total memory Kbits
 - 1,288 18x18-bit multipliers blocks
 - 2 PCI Express hard IP blocks
 - 744 user I/Os
 - 8 phase locked loops (PLLs)

- EP4SGX530C2
 - 531,200 logic elements (LEs)
 - 27,376K total memory Kbits
 - 1,024 18x18-bit multipliers blocks
 - 4 PCI Express hard IP Blocks
 - 744 user I/Os
 - 8 phase locked loops (PLLs)

Configuration device and USB Blaster circuit

- MAXII CPLD EPM2210 System Controller and Fast Passive Parallel (FPP) configuration
- On-board USB Blaster for use with the Quartus II Programmer
- Programmable PLL timing chip configured via MAX II CPLD
- Support JTAG mode

Memory devices

- 64MB Flash (32M x16) with a 16-bit data bus
- 2MB SSRAM (1M x 16)
- 2Kb EEPROM

Two DDR2 SO-DIMM sockets

- Up to 8GB capacity in total
- Maximum memory clock rate at 400MHz
- Theoretical Bandwidth over 102Gbps

SD Card socket

- Provides SPI and 4-bit SD mode for SD Card access

General user I/O

- 8 user controllable LEDs
- 2 seven-segment displays
- 8 user DIP switches

Push-buttons

- 4 user-defined inputs
- Normally high; generates one active-low pulse when the switch is pressed

Slide switches

- 4 slide switches for user-defined inputs
- When a switch is set to the DOWN or UP position, it causes logic 0 or 1, respectively.

On-Board Clocking Circuitry

- 50MHz/100MHz oscillator
- 2 SMA connector for external transceiver clock input
- 4 SMA connector for LVDS clock input/output
- 2 SMA connectors for clock output

- 1 SMA connector for external clock input

Four Serial ATA ports

- SATA 3.0 standard 6Gbps signaling rate

Four Gigabit Ethernet ports

- Integrated 1.25GHz SERDES

PCI Express x8 edge connector

- Support connection speed of Gen1 at 2.5Gbps/lane to Gen2 at 5.0Gbps/lane
- Connection established with PC motherboard with x8 or x16 PCI Express slot

Two High Speed Mezzanine Card (HSMC)

- 2 female-HSMC connectors
- Total of 12 pairs CDR-based transceivers at data rate up to 8.5Gbps
- Total 38 LVDS transmitter channels at data rate up to 1.6Gbps, and 36 LVDS receiver channels
- I/O voltage 2.5V

Two 40-pin expansion headers

- 72 FPGA I/O pins, as well as 4 power and ground lines, are brought out to two 40-pin expansion connectors
- 40-pin header is designed to accept a standard 40-pin ribbon cable used for IDE hard drives
- Compatible with I/O standard 3.3V

USB Host/Slave controller

- Complies fully with Universal Serial Bus Specification Rev. 2.0
- Support data transfer at high-speed, full-speed, and low-speed
- Support both USB host and device
- Three USB ports (one type mini-AB for host/device and two type A for host)
- Support Nios II with the Terasic driver

Power

- Standalone DC inputs 12V and 3.3V
- PCI Express edge connector power
- Optional PCI Express external power source
- On-Board power measurement circuitry

Chapter 2

Using the DE4 Board

This chapter gives instructions for using the DE4 board and its components.

It is strongly recommended that users read the *DE4 Getting Started Guide.pdf* before using the DE4 board. The document is located in the *Usermanual* folder on the **DE4 System CD**. The contents of the document include the following:

- Introduction to the DE4 development board
- DE4 development kit contents
- Key features
- Before you begin
- Software Installation
- Development board setup
- Programming the Stratix IV GX device on the DE4 board
- Programming through the Flash memory device

2.1 Configuration Options

■ JTAG FPGA Programming over USB-Blaster

The USB-blaster is implemented on the DE4 board to provide JTAG configuration through onboard USB-to-JTAG configuration logic using a type-B USB connector, a FTDI USB 2.0 Controller, and an Altera MAX II CPLD. Current configuration will be lost when the power is turned off. **Figure 2-1** illustrates the JTAG configuration scheme for the DE4.

To download a configuration bit stream into the Stratix IV GX FPGA, perform the following steps:

- Make sure that power is provided to the DE4 board
- Connect the USB cable supplied directly to the USB Blaster port of the DE4 board
- The FPGA can now be programmed in the Quartus II Programmer by selecting a configuration bit stream file with the .sof filename extension.

Please refer to *DE4 Getting Started Guide.pdf* for more detailed procedure of FPGA programming.

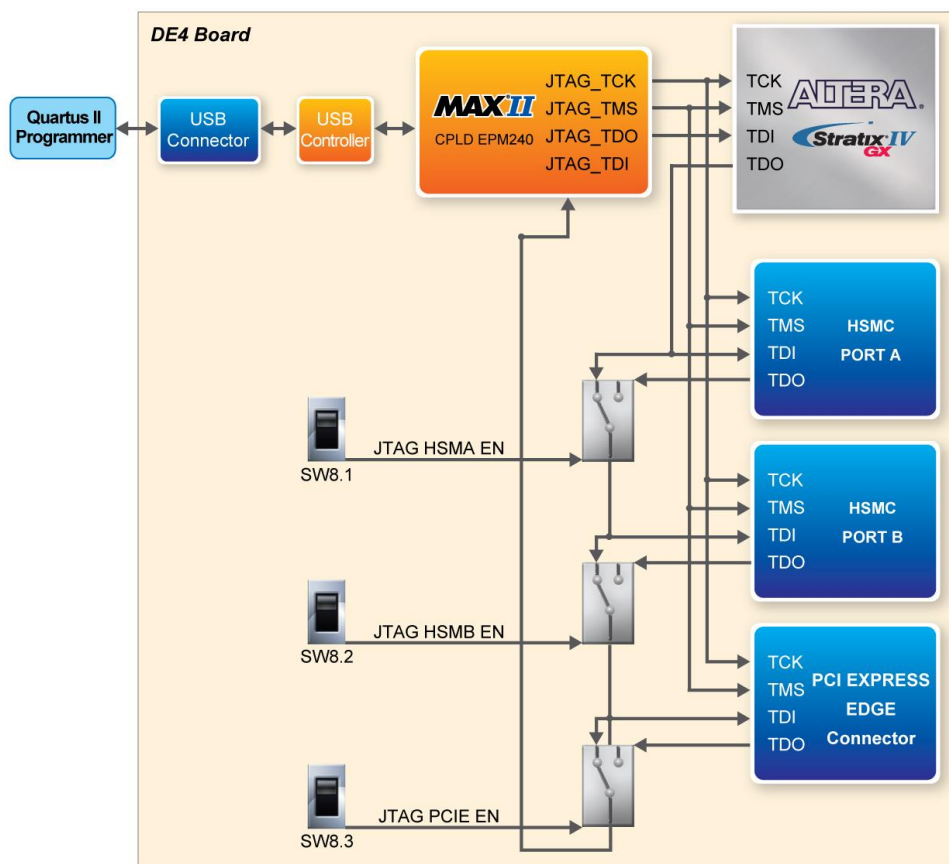

Figure 2-1 JTAG configuration scheme

■ Flash Programming

The DE4 development board contains a common flash interface (CFI) flash memory to meet the demands for a larger FPGA configuration storage. The parallel flash loader (PFL) feature in MAX II devices provides an efficient method to program CFI flash memory devices through the JTAG

interface and the logic to control configuration from the flash memory device to the Stratix IV GX FPGA. **Figure 2–2** depicts the connection setup between the CFI flash memory, Max II CPLD, and Stratix IV GX.

Please refer to the *DE4 Getting Started Guide.pdf* for the basic programming instruction on parallel flash loader on the CFI flash memory.

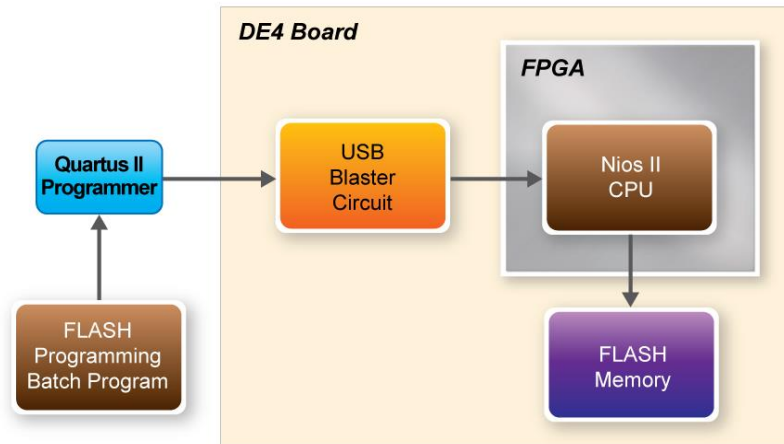

Figure 2–2 Flash programming scheme

■ Programming Flash Memory using batch file

The DE4 provides a program_flash batch file (`\demonstrations\de4_<Stratix device>\de4_board_update_portal\demo_batch\Program_flash`) to limit the steps that are taken when users program the flash memory on the DE4.

Software Requirements:

- Quartus II 9.1 SP2 or later
- Nios II IDE tools 9.1 SP2 or later

Program_flash folder contents:

- Program_flash.bat
- Program_flash.pl
- Program_flash.sh

- de4_board_update_portal.sof

Before you use the program_flash.bat batch file to program the flash memory, make sure the DE4 is turned on and USB cable is connected to the USB blaster port (J5). In addition, place the .sof and .elf file (optional) you wish to program/convert in the Program_flash directory.

Programming Flash Memory with .sof using Program_flash.bat

1. Launch the program_flash.bat batch file from the directory (*\demonstrations\de4_<Stratix device>\de4_board_update_portal\demo_batch\Program_flash*) of the **DE4 system CD-ROM**.
2. The flash program tool shows the menu options.

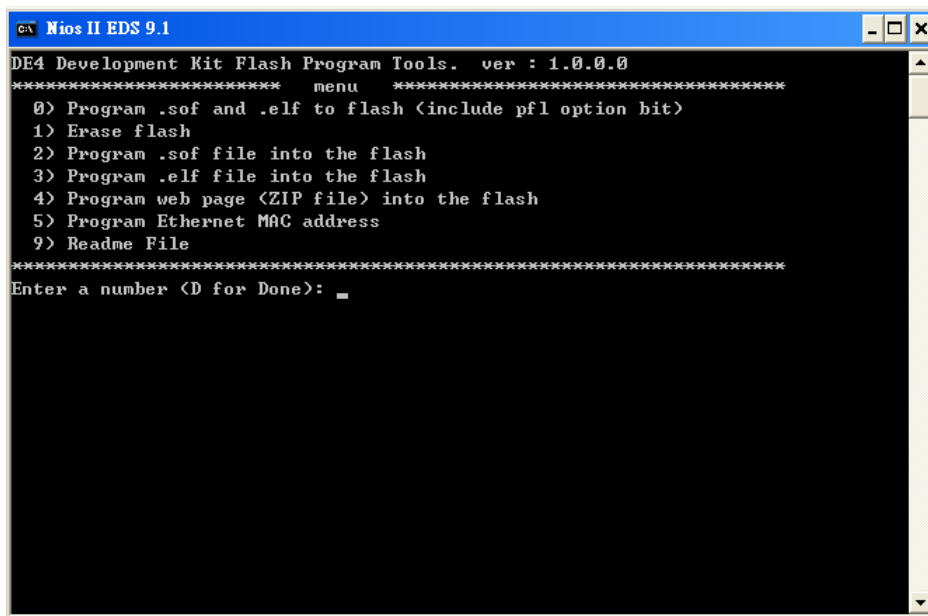

Figure 2–3 Flash program tools

3. Select option 2.

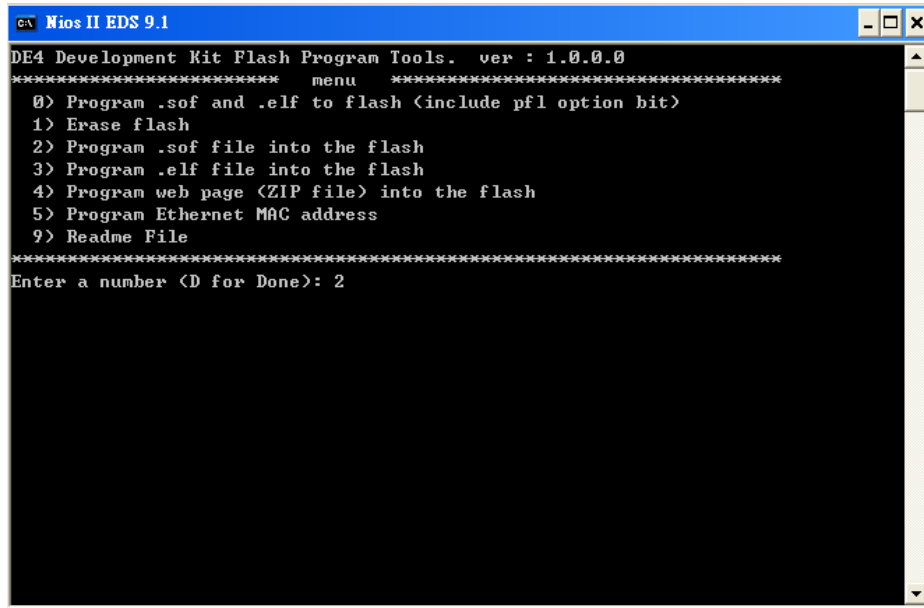

Figure 2–4 Option 2

4. Enter the .sof file name to be programmed onto the flash memory.

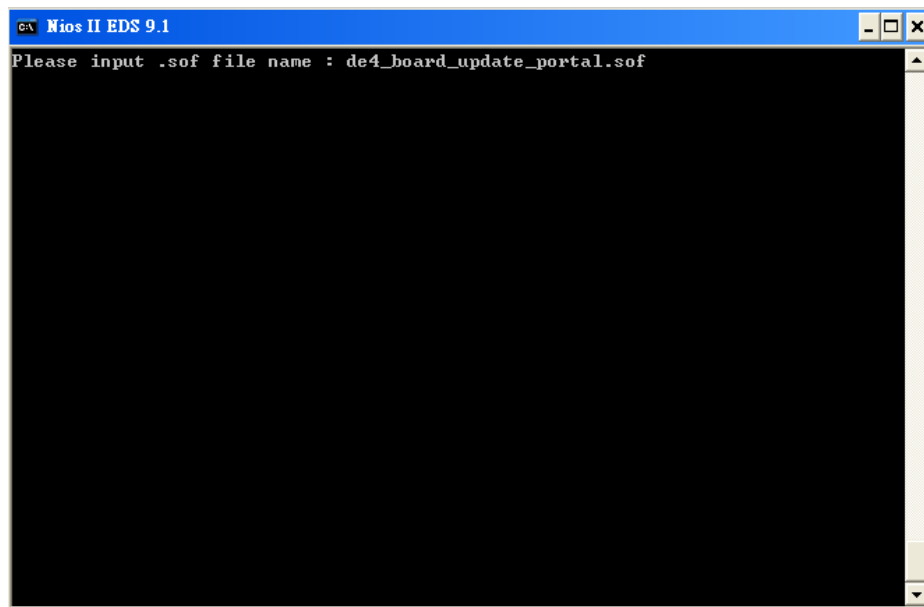

Figure 2–5 Enter .sof name to be program

5. The following lines will appear during flash programming: ‘Extracting Option bits SREC’, ‘Extracting FPGA Image SREC’, and ‘Deleting intermediate files’. If these lines don’t appear on the windows command, programming on the flash memory is not successfully setup. Please make sure Quartus II 9.1 SP2 and Nios II 9.1 IDE SP2 or later is used.

```

c:\Nios II EDS 9.1
Info: Peak virtual memory: 325 megabytes
Info: Processing ended: Thu Jul 01 20:31:52 2010
Info: Elapsed time: 00:00:42
Info: Total CPU time (on all processors): 00:00:42

Extracting Option bits SREC
Extracting FPGA Image SREC
Deleting intermediate files
Modify de4_hw.map.flash file ok.

Load board update portal file into FPGA, please wait ...

Info: *****
Info: Running Quartus II Programmer
Info: Version 9.1 Build 350 03/24/2010 Service Pack 2 SJ Full Version
Info: Copyright (C) 1991-2010 Altera Corporation. All rights reserved.
Info: Your use of Altera Corporation's design tools, logic functions
Info: and other software and tools, and its AMPP partner logic
Info: functions, and any output files from any of the foregoing
Info: (including device programming or simulation files), and any
Info: associated documentation or information are expressly subject
00940000 (80%): Programming ram License
Info: Subscription Agreement, Altera MegaCore Function License
Info: Agreement, or other applicable license agreement, including.

```

Figure 2-6 Loading .sof file to be program

6. Erasing flash.

```

c:\Nios II EDS 9.1
Info: programming logic devices manufactured by Altera and sold by
Info: Altera or its authorized distributors. Please refer to the
Info: applicable agreement for further details.
Info: Processing started: Fri Jun 11 16:50:30 2010
Info: Command: quartus_pgm -c USB-Blaster[USB-01] -m jtag -o p;de4_board_update_p
ortal.sof
Info: Using programming cable "USB-Blaster [USB-01]"
Info: Started Programmer operation at Fri Jun 11 16:50:43 2010
Info: Configuring device index 1
Info: Device 1 contains JTAG ID code 0x024090DD
Info: Configuration succeeded -- 1 device(s) configured
Info: Successfully performed operation(s)
Info: Ended Programmer operation at Fri Jun 11 16:51:05 2010
Info: Quartus II Programmer was successful. 0 errors, 0 warnings
Info: Peak virtual memory: 287 megabytes
Info: Processing ended: Fri Jun 11 16:51:05 2010
Info: Elapsed time: 00:00:35
Info: Total CPU time (on all processors): 00:00:12

Program flash, please wait a few minutes ...

Using cable "USB-Blaster [USB-01]", device 1, instance 0x00
Resetting and pausing target processor: OK
Checksummed/read 106kB in 4.9s
00320000 (26%): Erasing

```

Figure 2-7 Erasing flash

7. Programming flash.

```

c:\ Nios II EDS 9.1
Info: Altera or its authorized distributors. Please refer to the
Info: applicable agreement for further details.
Info: Processing started: Fri Jun 11 16:50:30 2010
Info: Command: quartus_pgm -c USB-Blaster[USB-01] -m jtag -o p:de4_board_update_p
ortal.sof
Info: Using programming cable "USB-Blaster [USB-01]"
Info: Started Programmer operation at Fri Jun 11 16:50:43 2010
Info: Configuring device index 1
Info: Device 1 contains JTAG ID code 0x024090DD
Info: Configuration succeeded -- 1 device(s) configured
Info: Successfully performed operation(s)
Info: Ended Programmer operation at Fri Jun 11 16:51:05 2010
Info: Quartus II Programmer was successful. 0 errors, 0 warnings
Info: Peak virtual memory: 287 megabytes
Info: Processing ended: Fri Jun 11 16:51:05 2010
Info: Elapsed time: 00:00:35
Info: Total CPU time (on all processors): 00:00:12

Program flash, please wait a few minutes ...

Using cable "USB-Blaster [USB-01]", device 1, instance 0x00
Resetting and pausing target processor: OK
Checksummed/read 106kB in 4.9s
Erased 11648kB in 86.7s (134.3kB/s)
00440000 (36%): Programming
  
```

Figure 2–8 Programming flash

8. Programming complete.

```

c:\ Nios II EDS 9.1
Info: Ended Programmer operation at Tue Jun 15 13:39:45 2010
Info: Quartus II Programmer was successful. 0 errors, 0 warnings
Info: Peak virtual memory: 287 megabytes
Info: Processing ended: Tue Jun 15 13:39:45 2010
Info: Elapsed time: 00:00:38
Info: Total CPU time (on all processors): 00:00:12

Program flash, please wait a few minutes ...

Using cable "USB-Blaster [USB-01]", device 1, instance 0x00
Resetting and pausing target processor: OK
Checksums took 2.3s
Erase not required
Programmed 11543KB in 443.2s (26.0KB/s)
Device contents checksummed OK
Leaving target processor paused
Using cable "USB-Blaster [USB-01]", device 1, instance 0x00
Resetting and pausing target processor: OK
Checksums took 0.0s
Erase not required
Programmed 1KB in 0.0s
Device contents checksummed OK
Leaving target processor paused

Press ENTER key to continuance...
  
```

Figure 2–9 Programming flash complete

2.2 Setup Elements

■ JTAG Control DIP Switch

The JTAG control DIP switch is provided to either remove or include devices in the active JTAG chain. The JTAG signals (TDI and TDO) found on the HSMC connectors and PCIe interface can be enabled using a 3-position DIP switch. In the “OFF” position, the TDI and TDO signals are looped, similarly in the “ON” position, the JTAG signals are bypassed. **Table 2–1** lists the position of the DIP switch and their associated interface.

Table 2–1 SW8 JTAG Control DIP Switch

<i>Board Reference</i>	<i>Signal Name</i>	<i>Description</i>	<i>Default</i>
SW8.1	JTAG_HSMA_EN	On : Bypass HSMA Off: HSMA In-chain	On
SW8.2	JTAG_HSMB_EN	On: Bypass HSMB Off: HSMB In-chain	On
SW8.3	JTAG_PCIE_EN	On: Bypass PCI Express Off : PCI Express In-Chain	On

■ PCI Express Control DIP switch

The PCI Express Control DIP switch is provided to enable or disable different configurations of the PCIe Connector. **Table 2–2** lists the switch controls and description.

Table 2–2 SW9 PCIe Control DIP Switch

<i>Board Reference</i>	<i>Signal Name</i>	<i>Description</i>	<i>Default</i>
SW9.1	PCIE_PRSENT2n_x1	On : Enable x1 presence detect Off: Disable x1 presence detect	Off
SW9.2	PCIE_PRSENT2n_x4	On : Enable x4 presence detect Off: Disable x4 presence detect	Off
SW9.3	PCIE_PRSENT2n_x8	On : Enable x8 presence detect Off: Disable x8 presence detect	On

2.3 Status Elements

The DE4 development board includes status LEDs. Please refer to [Table 2–3](#) for the status of the LED indicator.

Table 2–3 LED Indicators

<i>Board Reference</i>	<i>LED Name</i>	<i>Description</i>
D9	12-V Power	Illuminates when 12-V power is active.
D10	3.3-V Power	Illuminates when 3.3-V power is active.
D20	CONF DONE	Illuminates when the FPGA is successfully configured. Driven by the MAX II CPLD EPM2210 System Controller.
D18	Loading	Illuminates when the MAX II CPLD EPM2210 System Controller is actively configuring the FPGA. Driven by the MAX II CPLD EPM2210 System Controller with the Embedded Blaster CPLD.
D19	Error	Illuminates when the MAX II CPLD EPM2210 System Controller fails to configure the FPGA. Driven by the MAX II CPLD EPM2210 System Controller.
D12	USB Blaster Circuit	Illuminates when USB blaster circuit transmits or receives data.
D17	HSMC Port B Present	Illuminates when the HSMC port B has a board or cable plugged-in such that pin 160 becomes grounded. Driven by the add-in card
D16	HSMC Port A Present	Illuminates when the HSMC port A has a board or cable plugged-in such that pin 160 becomes grounded. Driven by the add-in card
RXD1	UART_RXD/GPIO Expansion 0 IO[7]	Illuminates when RS232 receives data or GPIO Expansion 0 IO[7] is transmits or receives.
TXD1	UART_TXD/GPIO Expansion 1 IO[9]	Illuminates when RS232 transmit data or GPIO Expansion 1 IO[9] is transmits or receives.
D15	USB Jack-Mini-USB-AB Port	Illuminates when USB Jack-Mini-USB port has a device.

D14	USB_TYPE_A port (Top USB)	Illuminates when the USB_TYPE_A port has a device.
D13	USB_TYPE_A port (Bottom USB)	Illuminates when the USB_TYPE_A port has a device.

2.4 General User Input/Output

■ Push-buttons

The DE4 board includes six push-buttons that allow you to interact with the Stratix IV GX device. Each push-button provides a high logic level or a low logic level when it is not pressed or pressed, respectively. **Table 2–4** lists the board references, signal names and their corresponding Stratix IV GX device pin numbers.

Table 2–4 Push-button Pin Assignments, Schematic Signal Names, and Functions

<i>Board Reference</i>	<i>Schematic Signal Name</i>	<i>Description</i>	<i>I/O Standard</i>	<i>Stratix IV GX Pin Number</i>
PB1	BUTTON0	High Logic Level when button not pressed	3.0-V	PIN_AH5
PB2	BUTTON1	High Logic Level when button not pressed	3.0-V	PIN_AG5
PB3	BUTTON2	High Logic Level when button not pressed	3.0-V	PIN_AG7
PB4	BUTTON3	High Logic Level when button not pressed	3.0-V	PIN_AH8
PB5	CPU_RESET_n	FPGA reset	2.5-V	PIN_V34
PB6	RE_CONFIGn	Max II EPM2210 System re-configuration	-	-

A CPU reset push-button (CPU_RESET_n) is an input to the Stratix IV GX device. It is intended to be the master reset signal for FPGA designs loaded into the Stratix IV GX device. The RE_CONFIGn push-button is used to force a reboot on the MAX II EPM2210 CPLD device.

■ Slide Switches and DIP Switch

There are also four slide switches and one 8-position DIP switch on the DE4 board to provide additional FPGA input control. Each switch is connected directly to a pin of the Stratix IV GX FPGA. When a slide switch is in the DOWN position or the UPPER position, it provides a low

logic level or a high logic level to the FPGA, respectively. For 8-position DIP switch, when a switch is in the DOWN position or the UPPER position, it provides a high logic level or a low logic level to the FPGA. **Table 2–5** and **Table 2–6** lists the signal names and their corresponding Stratix IV GX device pin numbers for slide switches and DIP switch respectively.

Table 2–5 Slide Switches Pin Assignments, Schematic Signal Names, and Functions

<i>Board Reference</i>	<i>Schematic Signal Name</i>	<i>Description</i>	<i>I/O Standard</i>	<i>Stratix IV GX Pin Number</i>
SW0	SLIDE_SW0	High logic level when SW in the UPPER position	2.5-V	PIN_J7
SW1	SLIDE_SW1		2.5-V	PIN_K7
SW2	SLIDE_SW2		3.0-V	PIN_AK6
SW3	SLIDE_SW3		2.5-V	PIN_L7

Table 2–6 DIP Switch Pin Assignments, Schematic Signal Names, and Functions

<i>Board Reference</i>	<i>Schematic Signal Name</i>	<i>Description</i>	<i>I/O Standard</i>	<i>Stratix IV GX Pin Number</i>
SW6	SW0	User-Defined DIP switch connected to FPGA device. When the switch is in the ON position, a logic 0 is selected. Similarly when the switch is in the OFF position, a logic 1 is selected.	3.0-V	PIN_AB13
SW6	SW1		3.0-V	PIN_AB12
SW6	SW2		3.0-V	PIN_AB11
SW6	SW3		3.0-V	PIN_AB10
SW6	SW4		3.0-V	PIN_AB9
SW6	SW5		3.0-V	PIN_AC8
SW6	SW6		3.0-V	PIN_AH6
SW6	SW7		3.0-V	PIN_AG6

■ LEDs

The DE4 board consists of 8 user-controllable LEDs to allow status and debugging signals to be driven to the LEDs from the designs loaded into the Stratix IV GX device. Each LED is driven directly by the Stratix IV GX FPGA. The LED is turned on or off when the associated pins are driven to a low or high logic level, respectively. A list of the pin names on the FPGA that are connected to the LEDs is given in **Table 2–7**.

Table 2–7 User LEDs Pin Assignments, Schematic Signal Names, and Functions

<i>Board Reference</i>	<i>Schematic Signal Name</i>	<i>Description</i>	<i>I/O Standard</i>	<i>Stratix IV GX Pin Number</i>
D1	LED0	User-Defined LEDs. Driving a logic 0 on the I/O port turns the LED ON. Driving a logic 1 on the I/O port turns the LED OFF.	2.5-V	PIN_V28
D2	LED1		2.5-V	PIN_W28
D3	LED2		2.5-V	PIN_R29
D4	LED3		2.5-V	PIN_P29
D5	LED4		2.5-V	PIN_N29
D6	LED5		2.5-V	PIN_M29
D7	LED6		2.5-V	PIN_M30
D8	LED7		2.5-V	PIN_N30

■ 7-Segment Displays

The DE4 board has two 7-segment displays. As indicated in the schematic in [Figure 2–10](#), the seven segments are connected to pins of the Stratix IV GX FPGA. Applying a low or high logic level to a segment to light it up or turns it off.

Each segment in a display is identified by an index listed from 0 to 6 with the positions given in [Figure 2–11](#). In addition, the decimal point is identified as DP. [Table 2–8](#) shows the mapping of the FPGA pin assignments to the 7-segment displays.

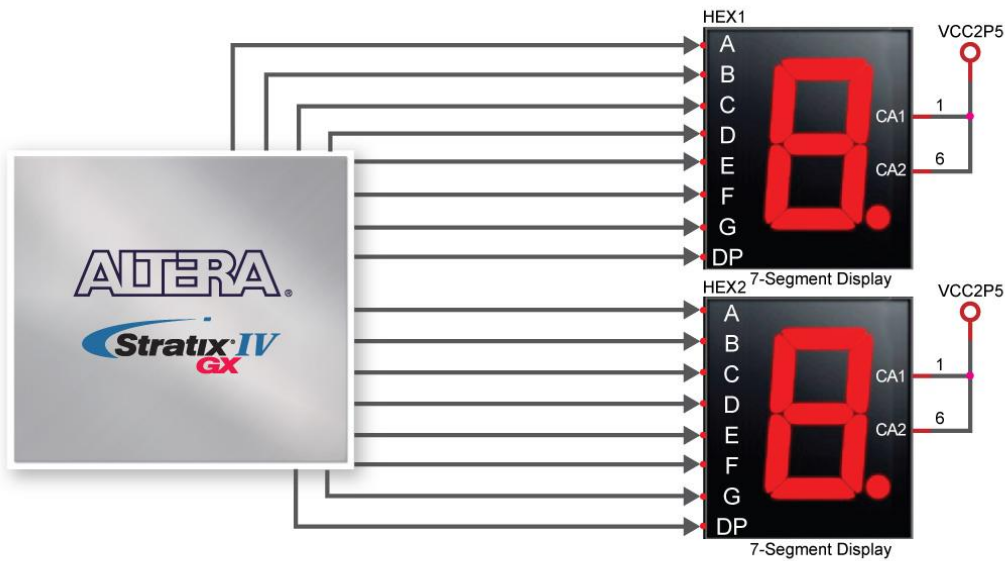

Figure 2–10 Connection between 7-segment displays and Stratix IV GX FPGA



Figure 2–11 Position and index of each segment in a 7-segment display

Table 2–8 7-Segment Display Pin Assignments, Schematic Signal Names, and Functions

Board Reference	Schematic Signal Name	Description	I/O Standard	Stratix IV GX Pin Number
HEX1	SEG1_D0	User-Defined 7-Segment Display. Driving a logic 0 on the I/O port turns the 7-segment signal ON. Driving a logic 1 on the I/O port turns the 7-segment signal OFF.	2.5-V	PIN_E31
HEX1	SEG1_D1		2.5-V	PIN_F31
HEX1	SEG1_D2		2.5-V	PIN_G31
HEX1	SEG1_D3		2.5-V	PIN_C34
HEX1	SEG1_D4		2.5-V	PIN_C33
HEX1	SEG1_D5		2.5-V	PIN_D33
HEX1	SEG1_D6		2.5-V	PIN_D34

HEX1	SEG1_DP	2.5-V	PIN_AL35
HEX0	SEG0_D0	2.5-V	PIN_L34
HEX0	SEG0_D1	2.5-V	PIN_M34
HEX0	SEG0_D2	2.5-V	PIN_M33
HEX0	SEG0_D3	2.5-V	PIN_H31
HEX0	SEG0_D4	2.5-V	PIN_J33
HEX0	SEG0_D5	2.5-V	PIN_L35
HEX0	SEG0_D6	2.5-V	PIN_K32
HEX0	SEG0_DP	2.5-V	PIN_AL34

2.5 High-Speed Mezzanine Cards

The DE4 development board contains two HSMC interfaces called port A and port B. The HSMC interface provides a mechanism to extend the peripheral-set of an FPGA host board by means of add-on cards, which can address today's high speed signaling requirement as well as low-speed device interface support. The HSMC interfaces support JTAG, clock outputs and inputs, high-speed serial I/O (transceivers), and single-ended or differential signaling.

Both the HSMC interfaces connected to the Stratix IV GX device are female HSMC connectors with each connector having a total of 172pins, including 121 signal pins (120 signal pins +1 PSNTn pin), 39 power pins, and 12 ground pins. The HSMC connector is based on the Samtec 0.5 mm pitch, surface-mount QSH family of high-speed, board-to-board connectors. The Stratix IV GX device provides +12 V DC and +3.3 V DC power to the mezzanine card through the HSMC connector. **Table 2–9** indicates the maximum power consumption for both HSMC ports A and B.

Table 2–9 Power Supply of the HSMC

<i>Supplied Voltage</i>	<i>Max. Current Limit</i>
12V	3A
3.3V	3A

There are three banks in this connector as **Figure 2–12** shows the bank arrangement of signals with respect to the Samtec connector. **Table 2–10** and **Table 2–11** show the mapping of the FPGA pin assignments to the HSMC connectors.

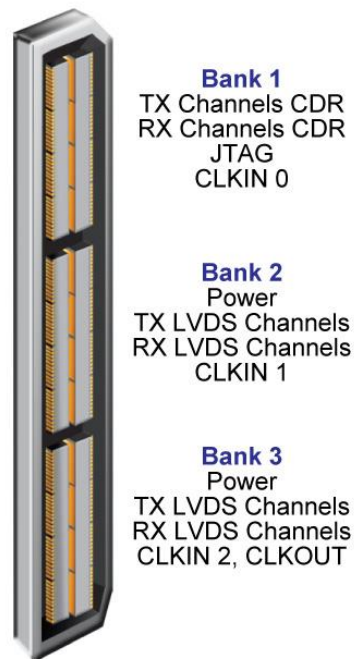

Figure 2–12 HSMC signal and bank diagram

■ **I/O Distribution**

The two HSMC interfaces combine have a total of 12 pairs CDR-based transceivers operating up to 8.5Gbps, 38 pairs LVDS transmitter channels at data rates up to 1.6Gbps, and 36 pairs LVDS receiver channels. Independently, Port A of the HSMC connector consists of 4 pairs CDR-based transceivers, 19 pairs LVDS transmitter channels, and 18 pairs LVDS receiver channels. While port B of the HSMC connector consists of 8 pairs CDR-based transceivers, 19 pairs LVDS transmitter channels, and 18 pairs LVDS receiver channels. Additionally, both ports A and B of the HSMC interfaces have 5 clock inputs and 4 clock outputs (2 differential clock inputs and outputs).

■ **I/O Standards**

The HSMC interface has programmable bi-directional I/O pins that can be used as 2.5-V. These pins can also be used as differential I/O standard including LVDS.

■ **Using THCB-HMF2 adapter card**

The purpose of the HSMC Height Extension Male to Female card (THCB-HMF2) included in the

DE4 kit package is to increase the height of the HSMC connector to avoid any obstruction that might take place as a HSMC daughter card is connected. The THCB-HMF2 adapter card can be connected to either ports, A or B of the HSMC connector shown in **Figure 2–13**.

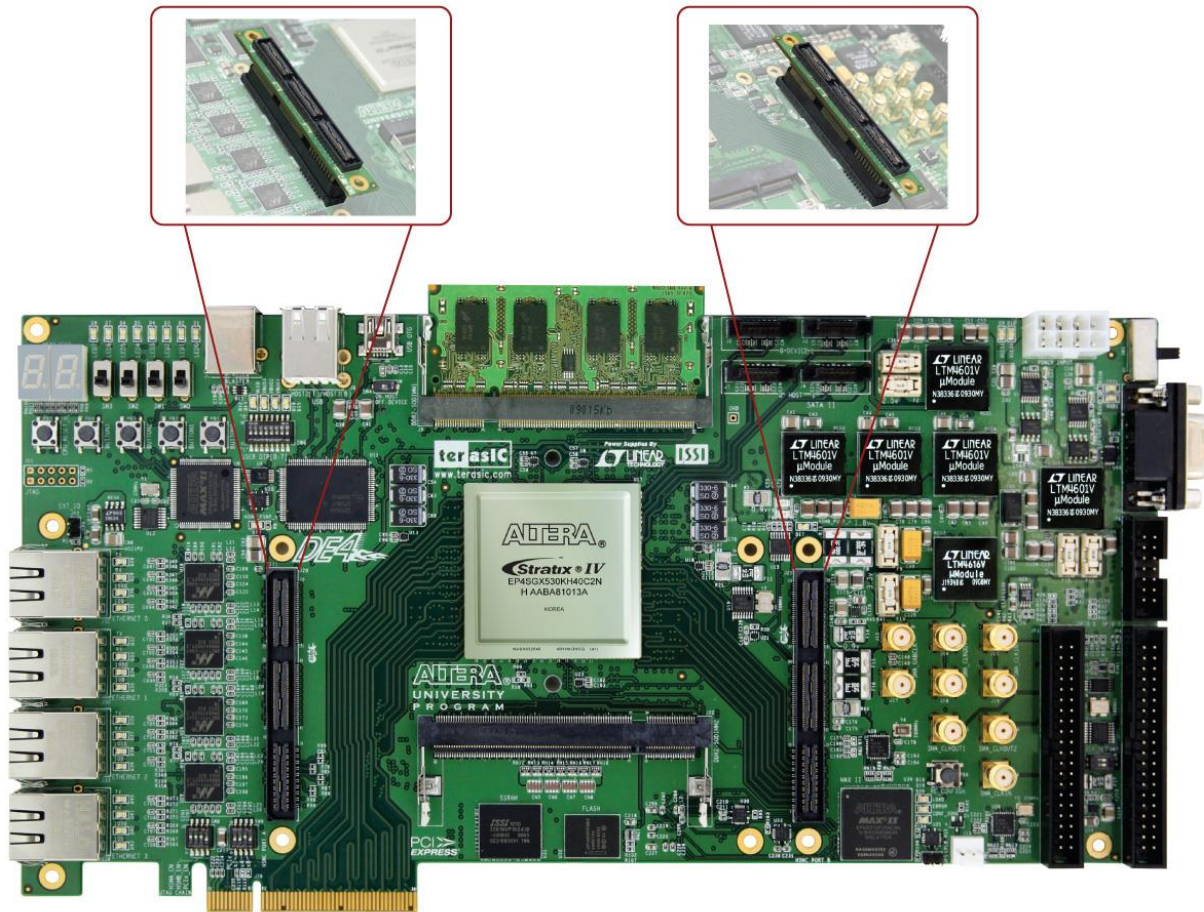

Figure 2–13 Connection setup between THCB-HMF2 adapter card and HSMC

■ JTAG Chain on HSMC

The JTAG chain on the HSMC can be activated through the 3-position DIP switch (SW8). If there is no connection established on the HSMC connectors, the 3-position DIP switch (SW8) are to set ‘On’, where the JTAG signals on the HSMC connectors are bypassed illustrated in **Figure 2–14**.

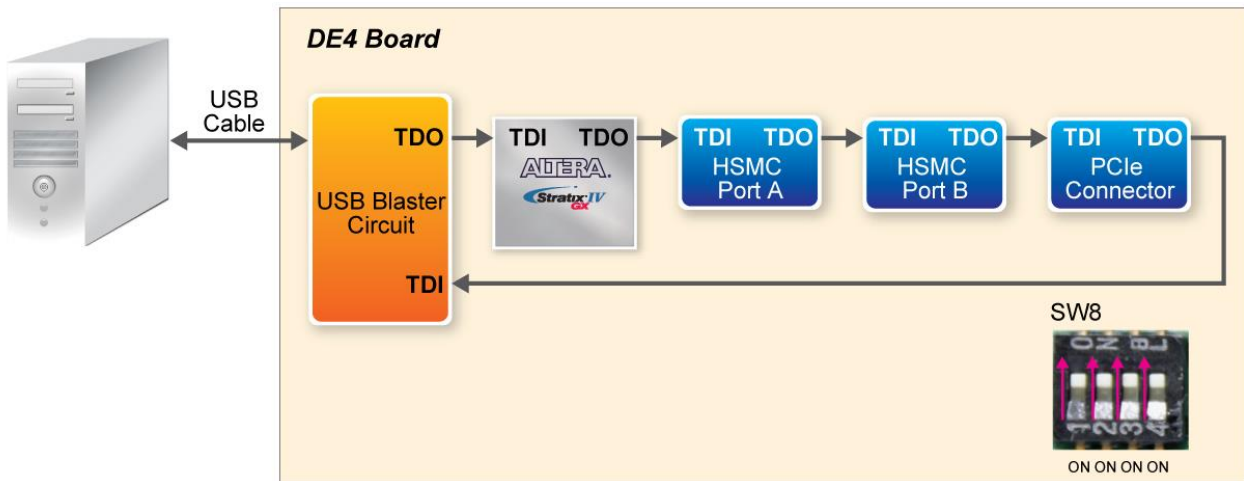

Figure 2-14 JTAG chain for a standalone DE4 board

If the HSMC-based daughter card connected to the HSMC connector uses the JTAG interface, the 3-position DIP switch (SW8) is set to ‘Off’ to which HSMC port is used. In this case, from **Figure 2-15** HSMC port A is used where position 1 of the SW8 is set to ‘Off’. Similarly, if the JTAG interface isn’t used on the HSMC-based daughter card, position 1 of SW8 is set to ‘On’ bypassing the JTAG signals as shown in **Figure 2-16**.

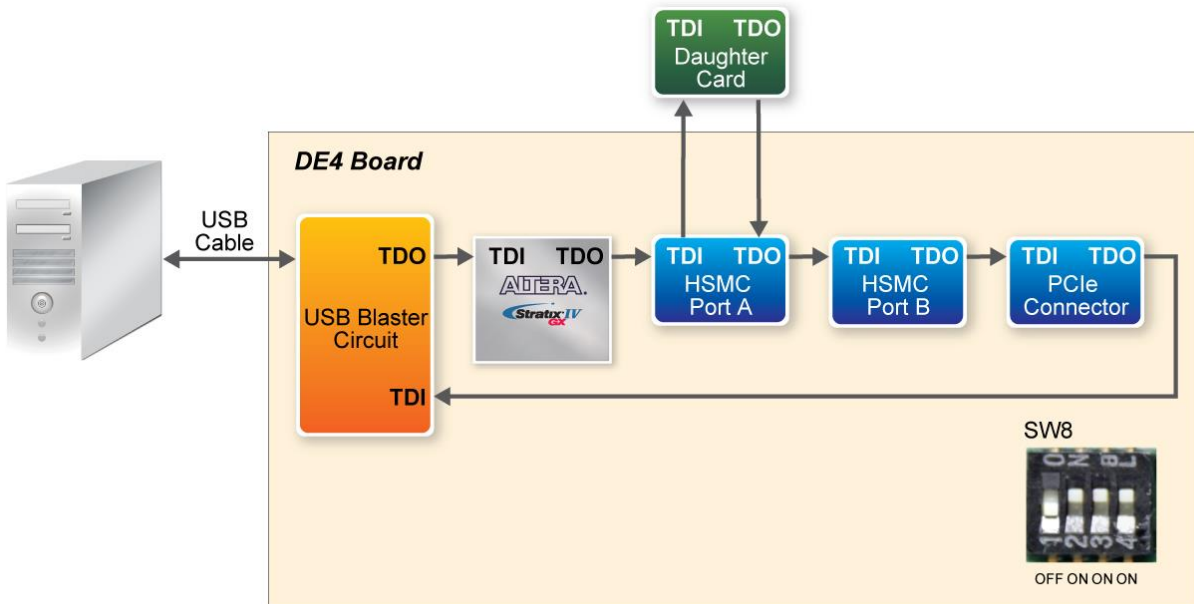

Figure 2-15 JTAG chain for a daughter card (uses JTAG) connected to HSMC port A of the DE4

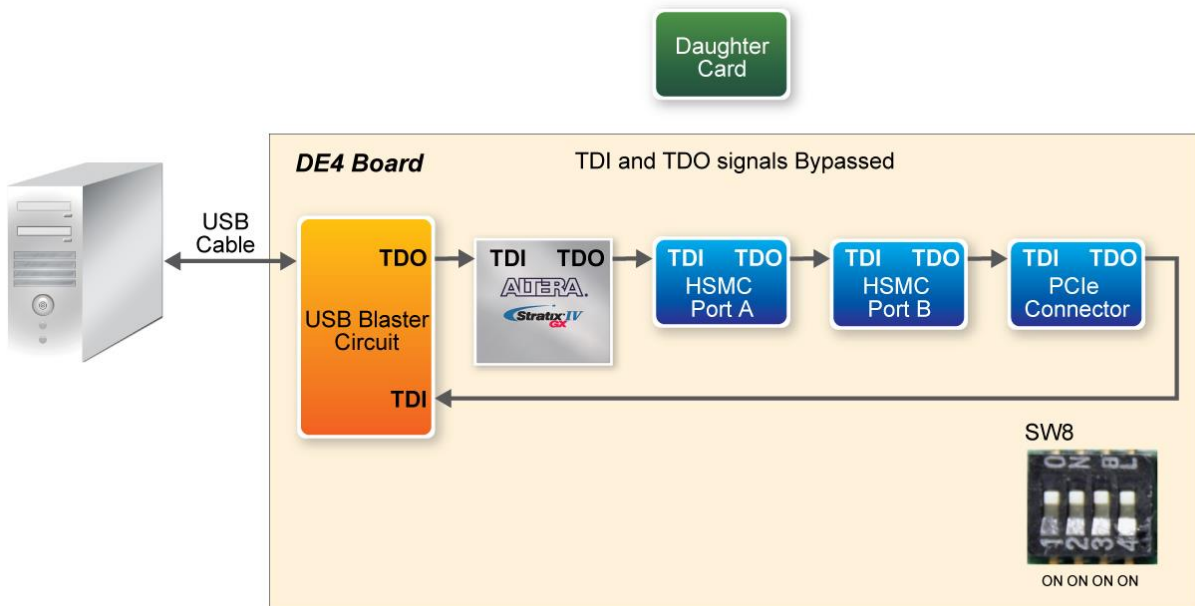

Figure 2–16 JTAG chain for a daughter card (JTAG not used) connected to HSMC port A of the DE4

■ Multi-FPGA high capacity platform through HSMC

The DE4 offers a choice of two Stratix IV GX devices, EP4SGX230 and EPSGX530 which offer logic elements (LEs) up to 228,000 and 531,200, respectively to provide the flexibility for users to select a suitable device in terms of design capacity. In situations where users’ design exceeds the capacity of the FPGA, the HSMC interface can be used to connect to other FPGA system boards creating a multi-FPGA scalable system. **Figure 2–17** illustrates a connection setup between two DE4 boards by connecting through port B and Port A of the HSMC connectors using a Samtec high-speed cable. Notice the JTAG switch (SW8) configuration setup where position 2 is set to ‘Off’ for port B connected on the DE4 and position 1 is set to ‘Off’ for port A connected on the DE4, allowing JTAG chain to be detected for both DE4 boards.

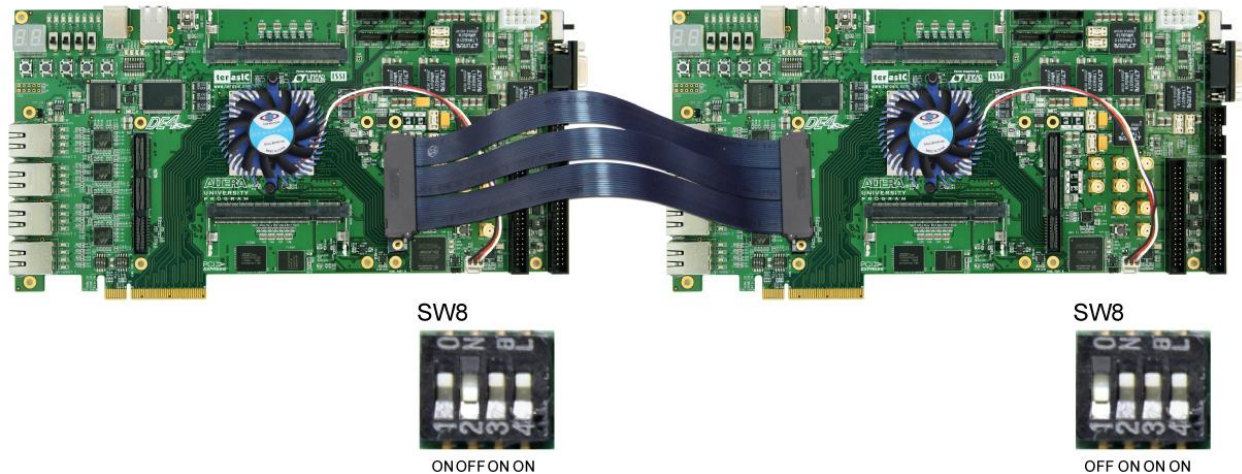

Figure 2-17 JTAG chain setup between two DE4 boards using HSMC interface

Table 2-10 HSMC Port B Pin Assignments, Schematic Signal Names, and Functions

<i>HSMC Pin #</i>	<i>Schematic Signal Name</i>	<i>Description</i>	<i>I/O Standard</i>	<i>Stratix IV GX Pin Number</i>
1	HSMB_GXB_TX_p7	Transceiver TX bit 7	1.4-V PCML	PIN_B4
2	HSMB_GXB_RX_p7	Transceiver RX bit 7	1.4-V PCML	PIN_C2
3	HSMB_GXB_TX_n7	Transceiver TX bit 7n	1.4-V PCML	PIN_B3
4	HSMB_GXB_RX_n7	Transceiver RX bit 7n	1.4-V PCML	PIN_C1
5	HSMB_GXB_TX_p6	Transceiver TX bit 6	1.4-V PCML	PIN_D4
6	HSMB_GXB_RX_p6	Transceiver RX bit 6	1.4-V PCML	PIN_E2
7	HSMB_GXB_TX_n6	Transceiver TX bit 6n	1.4-V PCML	PIN_D3
8	HSMB_GXB_RX_n6	Transceiver RX bit 6n	1.4-V PCML	PIN_E1
9	HSMB_GXB_TX_p5	Transceiver TX bit 5	1.4-V PCML	PIN_K4
10	HSMB_GXB_RX_p5	Transceiver RX bit 5	1.4-V PCML	PIN_L2
11	HSMB_GXB_TX_n5	Transceiver RX bit 5n	1.4-V PCML	PIN_K3
12	HSMB_GXB_RX_n5	Transceiver RX bit 5n	1.4-V PCML	PIN_L1
13	HSMB_GXB_TX_p4	Transceiver TX bit 4	1.4-V PCML	PIN_M4
14	HSMB_GXB_RX_p4	Transceiver RX bit 4	1.4-V PCML	PIN_N2
15	HSMB_GXB_TX_n4	Transceiver TX bit 4n	1.4-V PCML	PIN_M3
16	HSMB_GXB_RX_n4	Transceiver RX bit 4n	1.4-V PCML	PIN_N1
17	HSMB_GXB_TX_p3	Transceiver TX bit 3	1.4-V PCML	PIN_P4
18	HSMB_GXB_RX_p3	Transceiver RX bit 3	1.4-V PCML	PIN_R2
19	HSMB_GXB_TX_n3	Transceiver TX bit 3n	1.4-V PCML	PIN_P3
20	HSMB_GXB_RX_n3	Transceiver RX bit 3n	1.4-V PCML	PIN_R1
21	HSMB_GXB_TX_p2	Transceiver TX bit 2	1.4-V PCML	PIN_T4
22	HSMB_GXB_RX_p2	Transceiver RX bit 2	1.4-V PCML	PIN_U2
23	HSMB_GXB_TX_n2	Transceiver TX bit 2n	1.4-V PCML	PIN_T3

24	HSMB_GXB_RX_n2	Transceiver RX bit 2n	1.4-V PCML	PIN_U1
25	HSMB_GXB_TX_p1	Transceiver TX bit 1	1.4-V PCML	PIN_AB4
26	HSMB_GXB_RX_p1	Transceiver RX bit 1	1.4-V PCML	PIN_AC2
27	HSMB_GXB_TX_n1	Transceiver TX bit 1n	1.4-V PCML	PIN_AB3
28	HSMB_GXB_RX_n1	Transceiver RX bit 1n	1.4-V PCML	PIN_AC1
29	HSMB_GXB_TX_p0	Transceiver TX bit 0	1.4-V PCML	PIN_AD4
30	HSMB_GXB_RX_p0	Transceiver RX bit 0	1.4-V PCML	PIN_AE2
31	HSMB_GXB_TX_n0	Transceiver TX bit 0n	1.4-V PCML	PIN_AD3
32	HSMB_GXB_RX_n0	Transceiver RX bit 0n	1.4-V PCML	PIN_AE1
33	E_HSMC_SDA	Management serial data	1.8-V(*)	PIN_M19
34	E_HSMC_SCL	Management serial clock	1.8-V(*)	PIN_L19
35	HSMC_TCK	JTAG clock signal	2.5-V	-
36	HSMC_TMS	JTAG mode select signal	2.5-V	-
37	HSMB_TDO	JTAG data output	2.5-V	-
38	HSMC_TDI	JTAG data input	2.5-V	-
39	HSMB_OUT0	CMOS I/O	LVDS or 2.5-V	PIN_L8
40	HSMB_CLKIN0	Dedicated clock input	LVDS or 2.5-V	PIN_AA5
41	HSMB_D0	LVDS TX or CMOS I/O	LVDS or 2.5-V	PIN_H10
42	HSMB_D1	LVDS RX or CMOS I/O	LVDS or 2.5-V	PIN_D6
43	HSMB_D2	LVDS TX or CMOS I/O	LVDS or 2.5-V	PIN_G10
44	HSMB_D3	LVDS RX or CMOS I/O	LVDS or 2.5-V	PIN_C6
47	HSMB_TX_p0	LVDS TX bit 0 or CMOS I/O	LVDS or 2.5-V	PIN_K9
48	HSMB_RX_p0	LVDS RX bit 0 or CMOS I/O	LVDS or 2.5-V	PIN_D5
49	HSMB_TX_n0	LVDS TX bit 0n or CMOS I/O	LVDS or 2.5-V	PIN_J9
50	HSMB_RX_n0	LVDS RX bit 0n or CMOS I/O	LVDS or 2.5-V	PIN_C5
53	HSMB_TX_p1	LVDS TX bit 1 or CMOS I/O	LVDS or 2.5-V	PIN_K10
54	HSMB_RX_p1	LVDS RX bit 1 or CMOS I/O	LVDS or 2.5-V	PIN_D10
55	HSMB_TX_n1	LVDS TX bit 1n or CMOS I/O	LVDS or 2.5-V	PIN_J10
56	HSMB_RX_n1	LVDS RX bit 1n or CMOS I/O	LVDS or 2.5-V	PIN_C10
59	HSMB_TX_p2	LVDS TX bit 2 or CMOS I/O	LVDS or 2.5-V	PIN_N11
60	HSMB_RX_p2	LVDS RX bit 2 or CMOS I/O	LVDS or 2.5-V	PIN_D9
61	HSMB_TX_n2	LVDS TX bit 2n or CMOS I/O	LVDS or 2.5-V	PIN_N10
62	HSMB_RX_n2	LVDS RX bit 2n or CMOS I/O	LVDS or 2.5-V	PIN_C9
65	HSMB_TX_p3	LVDS TX bit 3 or CMOS I/O	LVDS or 2.5-V	PIN_N12
66	HSMB_RX_p3	LVDS RX bit 3 or CMOS I/O	LVDS or 2.5-V	PIN_D8
67	HSMB_TX_n3	LVDS TX bit 3n or CMOS I/O	LVDS or 2.5-V	PIN_M12
68	HSMB_RX_n3	LVDS RX bit 3n or CMOS I/O	LVDS or 2.5-V	PIN_C8
71	HSMB_TX_p4	LVDS TX bit 4 or CMOS I/O	LVDS or 2.5-V	PIN_R12
72	HSMB_RX_p4	LVDS RX bit 4 or CMOS I/O	LVDS or 2.5-V	PIN_D7
73	HSMB_TX_n4	LVDS TX bit 4n or CMOS I/O	LVDS or 2.5-V	PIN_R11
74	HSMB_RX_n4	LVDS RX bit 4n or CMOS I/O	LVDS or 2.5-V	PIN_C7
77	HSMB_TX_p5	LVDS TX bit 5 or CMOS I/O	LVDS or 2.5-V	PIN_T13
78	HSMB_RX_p5	LVDS RX bit 5 or CMOS I/O	LVDS or 2.5-V	PIN_F10

79	HSMB_TX_n5	LVDS TX bit 5n or CMOS I/O	LVDS or 2.5-V	PIN_T12
80	HSMB_RX_n5	LVDS RX bit 5n or CMOS I/O	LVDS or 2.5-V	PIN_E10
83	HSMB_TX_p6	LVDS TX bit 6 or CMOS I/O	LVDS or 2.5-V	PIN_R13
84	HSMB_RX_p6	LVDS RX bit 6 or CMOS I/O	LVDS or 2.5-V	PIN_G5
85	HSMB_TX_n6	LVDS TX bit 6n or CMOS I/O	LVDS or 2.5-V	PIN_P13
86	HSMB_RX_n6	LVDS RX bit 6n or CMOS I/O	LVDS or 2.5-V	PIN_F5
89	HSMB_TX_p7	LVDS TX bit 7 or CMOS I/O	LVDS or 2.5-V	PIN_H7
90	HSMB_RX_p7	LVDS RX bit 7 or CMOS I/O	LVDS or 2.5-V	PIN_G6
91	HSMB_TX_n7	LVDS TX bit 7n or CMOS I/O	LVDS or 2.5-V	PIN_G7
92	HSMB_RX_n7	LVDS RX bit 7n or CMOS I/O	LVDS or 2.5-V	PIN_F6
95	HSMB_OUT_p1	LVDS TX or CMOS I/O	LVDS or 2.5-V	PIN_K8
96	HSMB_CLKIN_p1	LVDS RX or CMOS I/O or differential clock input	LVDS or 2.5-V	PIN_W34
97	HSMB_OUT_n1	LVDS RX or CMOS I/O	LVDS or 2.5-V	PIN_J8
98	HSMB_CLKIN_n1	LVDS RX or CMOS I/O or differential clock input	LVDS or 2.5-V	PIN_W35
101	HSMB_TX_p8	LVDS TX bit 8 or CMOS I/O	LVDS or 2.5-V	PIN_M10
102	HSMB_RX_p8	LVDS RX bit 8 or CMOS I/O	LVDS or 2.5-V	PIN_F7
103	HSMB_TX_n8	LVDS TX bit 8n or CMOS I/O	LVDS or 2.5-V	PIN_L10
104	HSMB_RX_n8	LVDS RX bit 8n or CMOS I/O	LVDS or 2.5-V	PIN_E7
107	HSMB_TX_p9	LVDS TX bit 9 or CMOS I/O	LVDS or 2.5-V	PIN_M8
108	HSMB_RX_p9	LVDS RX bit 9 or CMOS I/O	LVDS or 2.5-V	PIN_G8
109	HSMB_TX_n9	LVDS TX bit 9n or CMOS I/O	LVDS or 2.5-V	PIN_M7
110	HSMB_RX_n9	LVDS RX bit 9n or CMOS I/O	LVDS or 2.5-V	PIN_F8
113	HSMB_TX_p10	LVDS TX bit 10 or CMOS I/O	LVDS or 2.5-V	PIN_M11
114	HSMB_RX_p10	LVDS RX bit 10 or CMOS I/O	LVDS or 2.5-V	PIN_G9
115	HSMB_TX_n10	LVDS TX bit 10n or CMOS I/O	LVDS or 2.5-V	PIN_L11
116	HSMB_RX_n10	LVDS RX bit 10n or CMOS I/O	LVDS or 2.5-V	PIN_F9
119	HSMB_TX_p11	LVDS TX bit 11 or CMOS I/O	LVDS or 2.5-V	PIN_N9
120	HSMB_RX_p11	LVDS RX bit 11 or CMOS I/O	LVDS or 2.5-V	PIN_N6
121	HSMB_TX_n11	LVDS TX bit 11n or CMOS I/O	LVDS or 2.5-V	PIN_P8
122	HSMB_RX_n11	LVDS RX bit 11n or CMOS I/O	LVDS or 2.5-V	PIN_N5
125	HSMB_TX_p12	LVDS TX bit 12 or CMOS I/O	LVDS or 2.5-V	PIN_R9
126	HSMB_RX_p12	LVDS RX bit 12 or CMOS I/O	LVDS or 2.5-V	PIN_M6
127	HSMB_TX_n12	LVDS TX bit 12n or CMOS I/O	LVDS or 2.5-V	PIN_R8
128	HSMB_RX_n12	LVDS RX bit 12n or CMOS I/O	LVDS or 2.5-V	PIN_L5
131	HSMB_TX_p13	LVDS TX bit 13 or CMOS I/O	LVDS or 2.5-V	PIN_U10
132	HSMB_RX_p13	LVDS RX bit 13 or CMOS I/O	LVDS or 2.5-V	PIN_R6
133	HSMB_TX_n13	LVDS TX bit 13n or CMOS I/O	LVDS or 2.5-V	PIN_T9
134	HSMB_RX_n13	LVDS RX bit 13n or CMOS I/O	LVDS or 2.5-V	PIN_R5
137	HSMB_TX_p14	LVDS TX bit 14 or CMOS I/O	LVDS or 2.5-V	PIN_V10
138	HSMB_RX_p14	LVDS RX bit 14 or CMOS I/O	LVDS or 2.5-V	PIN_R7
139	HSMB_TX_n14	LVDS TX bit 14n or CMOS I/O	LVDS or 2.5-V	PIN_V9

140	HSMB_RX_n14	LVDS RX bit 14n or CMOS I/O	LVDS or 2.5-V	PIN_P6
143	HSMB_TX_p15	LVDS TX bit 15 or CMOS I/O	LVDS or 2.5-V	PIN_T10
144	HSMB_RX_p15	LVDS RX bit 15 or CMOS I/O	LVDS or 2.5-V	PIN_V6
145	HSMB_TX_n15	LVDS TX bit 15n or CMOS I/O	LVDS or 2.5-V	PIN_R10
146	HSMB_RX_n15	LVDS RX bit 15n or CMOS I/O	LVDS or 2.5-V	PIN_U5
149	HSMB_TX_p16	LVDS TX bit 16 or CMOS I/O	LVDS or 2.5-V	PIN_V12
150	HSMB_RX_p16	LVDS RX bit 16 or CMOS I/O	LVDS or 2.5-V	PIN_W8
151	HSMB_TX_n16	LVDS TX bit 16n or CMOS I/O	LVDS or 2.5-V	PIN_V11
152	HSMB_RX_n16	LVDS RX bit 16n or CMOS I/O	LVDS or 2.5-V	PIN_W7
155	HSMB_CLKOUT_p2	LVDS TX or CMOS I/O or differential clock input/output	LVDS or 2.5-V	PIN_W12
156	HSMB_CLKIN_p2	LVDS RX or CMOS I/O or differential clock input	LVDS or 2.5-V	PIN_W6
157	HSMB_CLKOUT_n2	LVDS TX or CMOS I/O or differential clock input/output	LVDS or 2.5-V	PIN_W11
158	HSMB_CLKIN_n2	LVDS RX or CMOS I/O or differential clock input	LVDS or 2.5-V	PIN_W5

Note for **Table 2–10**:

*The signals E_HSMC_SDA and E_HSMC_SCL are level-shifted from 3.3V (FPGA) to 1.8V (HSMC).

Table 2–11 HSMC Port A Pin Assignments, Schematic Signal Names, and Functions

<i>HSMC Pin #</i>	<i>Schematic Signal Name</i>	<i>Description</i>	<i>I/O Standard</i>	<i>Stratix IV GX Pin Number</i>
1	-	-	-	-
2	-	-	-	-
3	-	-	-	-
4	-	-	-	-
5	-	-	-	-
6	-	-	-	-
7	-	-	-	-
8	-	-	-	-
9	-	-	-	-
10	-	-	-	-
11	-	-	-	-
12	-	-	-	-
13	-	-	-	-
14	-	-	-	-
15	-	-	-	-
16	-	-	-	-
17	HSMA_GXB_TX_p3	Transceiver TX bit 3	1.4-V PCML	PIN_B36

18	HSMA_GXB_RX_p3	Transceiver RX bit 3	1.4-V PCML	PIN_C38
19	HSMA_GXB_TX_n3	Transceiver TX bit 3n	1.4-V PCML	PIN_B37
20	HSMA_GXB_RX_n3	Transceiver RX bit 3n	1.4-V PCML	PIN_C39
21	HSMA_GXB_TX_p2	Transceiver TX bit 2	1.4-V PCML	PIN_D36
22	HSMA_GXB_RX_p2	Transceiver RX bit 2	1.4-V PCML	PIN_E38
23	HSMA_GXB_TX_n2	Transceiver TX bit 2n	1.4-V PCML	PIN_D37
24	HSMA_GXB_RX_n2	Transceiver RX bit 2n	1.4-V PCML	PIN_E39
25	HSMA_GXB_TX_p1	Transceiver TX bit 1	1.4-V PCML	PIN_K36
26	HSMA_GXB_RX_p1	Transceiver RX bit 1	1.4-V PCML	PIN_L38
27	HSMA_GXB_TX_n1	Transceiver TX bit 1n	1.4-V PCML	PIN_K37
28	HSMA_GXB_RX_n1	Transceiver RX bit 1n	1.4-V PCML	PIN_L39
29	HSMA_GXB_TX_p0	Transceiver TX bit 0	1.4-V PCML	PIN_M36
30	HSMA_GXB_RX_p0	Transceiver RX bit 0	1.4-V PCML	PIN_N38
31	HSMA_GXB_TX_n0	Transceiver TX bit 0n	1.4-V PCML	PIN_M37
32	HSMA_GXB_RX_n0	Transceiver RX bit 0n	1.4-V PCML	PIN_N39
33	E_HSMC_SDA	Management serial data	1.8-V(*)	PIN_M19
34	E_HSMC_SCL	Management serial clock	1.8-V(*)	PIN_L19
35	HSMC_TCK	JTAG clock signal	2.5-V	-
36	HSMC_TMS	JTAG mode select signal	2.5-V	-
37	HSMA_TDO	JTAG data output	2.5-V	-
38	HSMA_TDI	JTAG data input	2.5-V	-
39	HSMA_OUT0	CMOS I/O	LVDS or 2.5-V	PIN_AF29
40	HSMA_CLKIN0	Dedicated clock input	LVDS or 2.5-V	PIN_AC34
41	HSMA_D0	LVDS TX or CMOS I/O	LVDS or 2.5-V	PIN_AC26
42	HSMA_D1	LVDS RX or CMOS I/O	LVDS or 2.5-V	PIN_AC31
43	HSMA_D2	LVDS TX or CMOS I/O	LVDS or 2.5-V	PIN_AD26
44	HSMA_D3	LVDS RX or CMOS I/O	LVDS or 2.5-V	PIN_AC32
47	HSMA_TX_p0	LVDS TX bit 0 or CMOS I/O	LVDS or 2.5-V	PIN_AB27
48	HSMA_RX_p0	LVDS RX bit 0 or CMOS I/O	LVDS or 2.5-V	PIN_AJ32
49	HSMA_TX_n0	LVDS TX bit 0n or CMOS I/O	LVDS or 2.5-V	PIN_AB28
50	HSMA_RX_n0	LVDS RX bit 0n or CMOS I/O	LVDS or 2.5-V	PIN_AK33
53	HSMA_TX_p1	LVDS TX bit 1 or CMOS I/O	LVDS or 2.5-V	PIN_AB30
54	HSMA_RX_p1	LVDS RX bit 1 or CMOS I/O	LVDS or 2.5-V	PIN_AH34
55	HSMA_TX_n1	LVDS TX bit 1n or CMOS I/O	LVDS or 2.5-V	PIN_AB31
56	HSMA_RX_n1	LVDS RX bit 1n or CMOS I/O	LVDS or 2.5-V	PIN_AH35
59	HSMA_TX_p2	LVDS TX bit 2 or CMOS I/O	LVDS or 2.5-V	PIN_AD27
60	HSMA_RX_p2	LVDS RX bit 2 or CMOS I/O	LVDS or 2.5-V	PIN_AJ34
61	HSMA_TX_n2	LVDS TX bit 2n or CMOS I/O	LVDS or 2.5-V	PIN_AE27
62	HSMA_RX_n2	LVDS RX bit 2n or CMOS I/O	LVDS or 2.5-V	PIN_AJ35
65	HSMA_TX_p3	LVDS TX bit 3 or CMOS I/O	LVDS or 2.5-V	PIN_AD28
66	HSMA_RX_p3	LVDS RX bit 3 or CMOS I/O	LVDS or 2.5-V	PIN_AK34
67	HSMA_TX_n3	LVDS TX bit 3n or CMOS I/O	LVDS or 2.5-V	PIN_AD29
68	HSMA_RX_n3	LVDS RX bit 3n or CMOS I/O	LVDS or 2.5-V	PIN_AK35

71	HSMA_TX_p4	LVDS TX bit 4 or CMOS I/O	LVDS or 2.5-V	PIN_AE28
72	HSMA_RX_p4	LVDS RX bit 4 or CMOS I/O	LVDS or 2.5-V	PIN_AN30
73	HSMA_TX_n4	LVDS TX bit 4n or CMOS I/O	LVDS or 2.5-V	PIN_AE29
74	HSMA_RX_n4	LVDS RX bit 4n or CMOS I/O	LVDS or 2.5-V	PIN_AP30
77	HSMA_TX_p5	LVDS TX bit 5 or CMOS I/O	LVDS or 2.5-V	PIN_AE26
78	HSMA_RX_p5	LVDS RX bit 5 or CMOS I/O	LVDS or 2.5-V	PIN_AM34
79	HSMA_TX_n5	LVDS TX bit 5n or CMOS I/O	LVDS or 2.5-V	PIN_AF26
80	HSMA_RX_n5	LVDS RX bit 5n or CMOS I/O	LVDS or 2.5-V	PIN_AM35
83	HSMA_TX_p6	LVDS TX bit 6 or CMOS I/O	LVDS or 2.5-V	PIN_AG31
84	HSMA_RX_p6	LVDS RX bit 6 or CMOS I/O	LVDS or 2.5-V	PIN_AM31
85	HSMA_TX_n6	LVDS TX bit 6n or CMOS I/O	LVDS or 2.5-V	PIN_AG32
86	HSMA_RX_n6	LVDS RX bit 6n or CMOS I/O	LVDS or 2.5-V	PIN_AN31
89	HSMA_TX_p7	LVDS TX bit 7 or CMOS I/O	LVDS or 2.5-V	PIN_AG29
90	HSMA_RX_p7	LVDS RX bit 7 or CMOS I/O	LVDS or 2.5-V	PIN_AN33
91	HSMA_TX_n7	LVDS TX bit 7n or CMOS I/O	LVDS or 2.5-V	PIN_AH29
92	HSMA_RX_n7	LVDS RX bit 7n or CMOS I/O	LVDS or 2.5-V	PIN_AP34
95	HSMA_OUT_p1	LVDS TX or CMOS I/O	LVDS or 2.5-V	PIN_AG28
96	HSMA_CLKIN_p1	LVDS RX or CMOS I/O or differential clock input	LVDS or 2.5-V	PIN_AB34
97	HSMA_OUT_n1	LVDS RX or CMOS I/O	LVDS or 2.5-V	PIN_AH28
98	HSMA_CLKIN_n1	LVDS RX or CMOS I/O or differential clock input	LVDS or 2.5-V	PIN_AA35
101	HSMA_TX_p8	LVDS TX bit 8 or CMOS I/O	LVDS or 2.5-V	PIN_AC28
102	HSMA_RX_p8	LVDS RX bit 8 or CMOS I/O	LVDS or 2.5-V	PIN_AP32
103	HSMA_TX_n8	LVDS TX bit 8n or CMOS I/O	LVDS or 2.5-V	PIN_AC29
104	HSMA_RX_n8	LVDS RX bit 8n or CMOS I/O	LVDS or 2.5-V	PIN_AR32
107	HSMA_TX_p9	LVDS TX bit 9 or CMOS I/O	LVDS or 2.5-V	PIN_AJ29
108	HSMA_RX_p9	LVDS RX bit 9 or CMOS I/O	LVDS or 2.5-V	PIN_AR31
109	HSMA_TX_n9	LVDS TX bit 9n or CMOS I/O	LVDS or 2.5-V	PIN_AK29
110	HSMA_RX_n9	LVDS RX bit 9n or CMOS I/O	LVDS or 2.5-V	PIN_AT30
113	HSMA_TX_p10	LVDS TX bit 10 or CMOS I/O	LVDS or 2.5-V	PIN_AD30
114	HSMA_RX_p10	LVDS RX bit 10 or CMOS I/O	LVDS or 2.5-V	PIN_AT33
115	HSMA_TX_n10	LVDS TX bit 10n or CMOS I/O	LVDS or 2.5-V	PIN_AD31
116	HSMA_RX_n10	LVDS RX bit 10n or CMOS I/O	LVDS or 2.5-V	PIN_AU33
119	HSMA_TX_p11	LVDS TX bit 11 or CMOS I/O	LVDS or 2.5-V	PIN_AK32
120	HSMA_RX_p11	LVDS RX bit 11 or CMOS I/O	LVDS or 2.5-V	PIN_AU34
121	HSMA_TX_n11	LVDS TX bit 11n or CMOS I/O	LVDS or 2.5-V	PIN_AL32
122	HSMA_RX_n11	LVDS RX bit 11n or CMOS I/O	LVDS or 2.5-V	PIN_AV34
125	HSMA_TX_p12	LVDS TX bit 12 or CMOS I/O	LVDS or 2.5-V	PIN_AG27
126	HSMA_RX_p12	LVDS RX bit 12 or CMOS I/O	LVDS or 2.5-V	PIN_AT32
127	HSMA_TX_n12	LVDS TX bit 12n or CMOS I/O	LVDS or 2.5-V	PIN_AH27
128	HSMA_RX_n12	LVDS RX bit 12n or CMOS I/O	LVDS or 2.5-V	PIN_AU32
131	HSMA_TX_p13	LVDS TX bit 13 or CMOS I/O	LVDS or 2.5-V	PIN_AK31

132	HSMA_RX_p13	LVDS RX bit 13 or CMOS I/O	LVDS or 2.5-V	PIN_AT31
133	HSMA_TX_n13	LVDS TX bit 13n or CMOS I/O	LVDS or 2.5-V	PIN_AL31
134	HSMA_RX_n13	LVDS RX bit 13n or CMOS I/O	LVDS or 2.5-V	PIN_AU31
137	HSMA_TX_p14	LVDS TX bit 14 or CMOS I/O	LVDS or 2.5-V	PIN_AJ31
138	HSMA_RX_p14	LVDS RX bit 14 or CMOS I/O	LVDS or 2.5-V	PIN_AP35
139	HSMA_TX_n14	LVDS TX bit 14n or CMOS I/O	LVDS or 2.5-V	PIN_AH30
140	HSMA_RX_n14	LVDS RX bit 14n or CMOS I/O	LVDS or 2.5-V	PIN_AR35
143	HSMA_TX_p15	LVDS TX bit 15 or CMOS I/O	LVDS or 2.5-V	PIN_AL29
144	HSMA_RX_p15	LVDS RX bit 15 or CMOS I/O	LVDS or 2.5-V	PIN_AN32
145	HSMA_TX_n15	LVDS TX bit 15n or CMOS I/O	LVDS or 2.5-V	PIN_AM29
146	HSMA_RX_n15	LVDS RX bit 15n or CMOS I/O	LVDS or 2.5-V	PIN_AP33
149	HSMA_TX_p16	LVDS TX bit 16 or CMOS I/O	LVDS or 2.5-V	PIN_AK30
150	HSMA_RX_p16	LVDS RX bit 16 or CMOS I/O	LVDS or 2.5-V	PIN_AT34
151	HSMA_TX_n16	LVDS TX bit 16n or CMOS I/O	LVDS or 2.5-V	PIN_AL30
152	HSMA_RX_n16	LVDS RX bit 16n or CMOS I/O	LVDS or 2.5-V	PIN_AR34
155	HSMA_CLKOUT_p2	LVDS TX or CMOS I/O or differential clock input/output	LVDS or 2.5-V	PIN_AG34
156	HSMA_CLKIN_p2	LVDS RX or CMOS I/O or differential clock input	LVDS or 2.5-V	PIN_AF34
157	HSMA_CLKOUT_n2	LVDS TX or CMOS I/O or differential clock input/output	LVDS or 2.5-V	PIN_AG35
158	HSMA_CLKIN_n2	LVDS RX or CMOS I/O or differential clock input	LVDS or 2.5-V	PIN_AE35

Note for **Table 2–11**:

*The signals E_HSMC_SDA and E_HSMC_SCL are level-shifted from 3.3V (FPGA) to 1.8V (HSMC).

2.6 GPIO Expansion Headers

The DE4 Board consists of two 40-pin expansion headers as shown in **Figure 2–18**. Each header has 36 pins connected to the Stratix IV GX FPGA, with the other 4 pins providing DC +5V (VCC5), DC +3.3V (VCC33), and two GND pins. Among these 36 I/O pins for connector JP3, there are 2 pins connected to the differential clock inputs of the FPGA. The I/O pins on the expansion headers have a 3.0-V I/O standard.

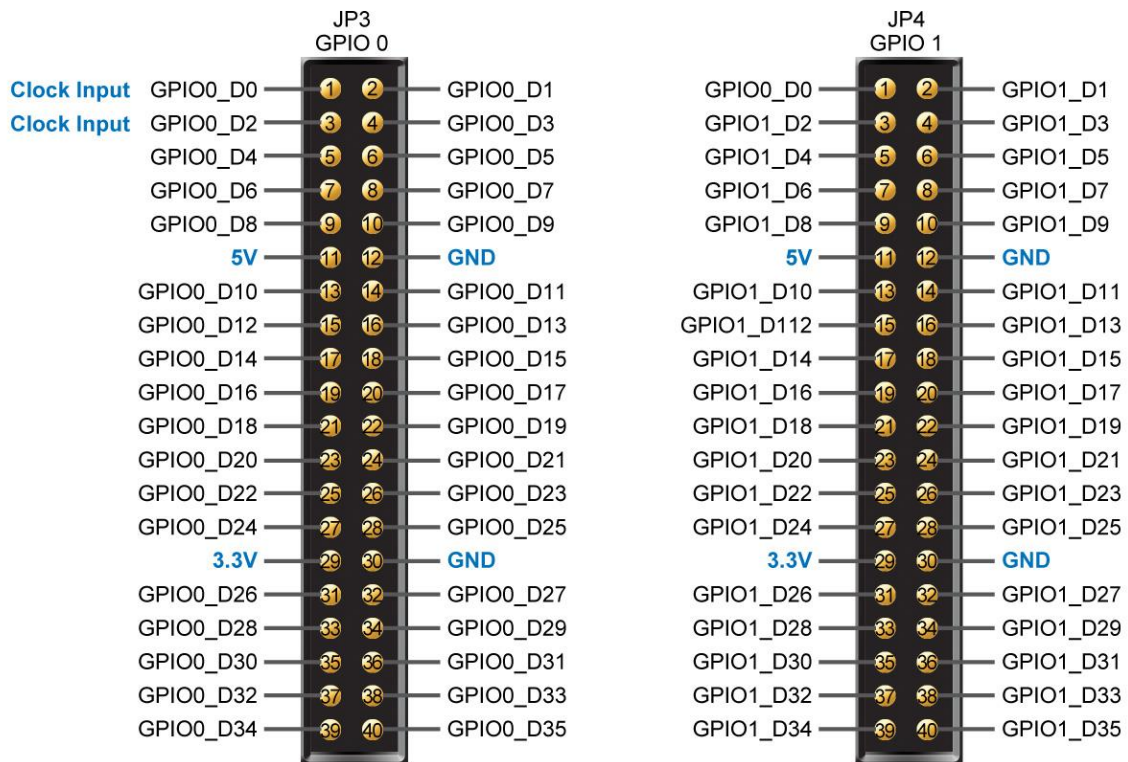

Figure 2-18 Pin distribution of the GPIO expansion headers

Finally, **Figure 2-19** shows the connections between the GPIO expansion headers and Stratix IV GX.

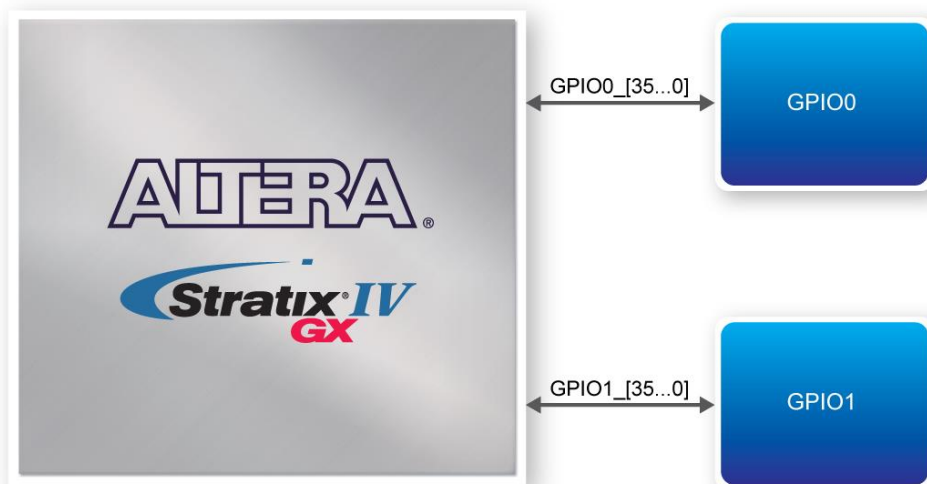

Figure 2-19 Connection between the GPIO expansion headers and Stratix IV GX

■ External 14-pin Expansion Header

An external 14-pin expansion header (JP6) is provided on the DE4 which offers additional connectivity and I/Os for general purpose applications. The header has 7 pins connected to the Stratix IV GX FPGA, with the other pins providing a DC +3.3V (VCC33) and 6 GND pins. Note the 6 data I/O pins on the 14-pin expansion header share the same bus with the GPIO expansion header (JP3).

The pin assignments are given in [Table 2–12](#), [Table 2–13](#) and [Table 2–14](#).

Table 2–12 GPIO Expansion Header (JP3) Pin Assignments, Schematic Signal Names, and Functions

<i>Schematic Signal Name</i>	<i>Description</i>	<i>I/O Standard</i>	<i>Stratix IV GX Pin Number</i>
GPIO0_D0	GPIO Expansion 0 IO[0](Clock In)	3.0-V or LVDS	PIN_AF6
GPIO0_D1	GPIO Expansion 0 IO[1]	3.0-V	PIN_AU9
GPIO0_D2	GPIO Expansion 0 IO[2](Clock In)	3.0-V or LVDS	PIN_AE5
GPIO0_D3	GPIO Expansion 0 IO[3]	3.0-V	PIN_AR8
GPIO0_D4	GPIO Expansion 0 IO[4]	3.0-V	PIN_AN9
GPIO0_D5	GPIO Expansion 0 IO[5]	3.0-V	PIN_AP9
GPIO0_D6	GPIO Expansion 0 IO[6]	3.0-V	PIN_AV5
GPIO0_D7	GPIO Expansion 0 IO[7]	3.0-V	PIN_AW6
GPIO0_D8	GPIO Expansion 0 IO[8]	3.0-V	PIN_AV7
GPIO0_D9	GPIO Expansion 0 IO[9]	3.0-V	PIN_AW7
GPIO0_D10	GPIO Expansion 0 IO[10]	3.0-V	PIN_AT5
GPIO0_D11	GPIO Expansion 0 IO[11]	3.0-V	PIN_AT8
GPIO0_D12	GPIO Expansion 0 IO[12]	3.0-V	PIN_AP5
GPIO0_D13	GPIO Expansion 0 IO[13]	3.0-V	PIN_AP7
GPIO0_D14	GPIO Expansion 0 IO[14]	3.0-V	PIN_AN5
GPIO0_D15	GPIO Expansion 0 IO[15]	3.0-V	PIN_AN10
GPIO0_D16	GPIO Expansion 0 IO[16]	3.0-V	PIN_AM5
GPIO0_D17	GPIO Expansion 0 IO[17]	3.0-V	PIN_AM10
GPIO0_D18	GPIO Expansion 0 IO[18]	3.0-V	PIN_AL10
GPIO0_D19	GPIO Expansion 0 IO[19]	3.0-V	PIN_AM8
GPIO0_D20	GPIO Expansion 0 IO[20]	3.0-V	PIN_AL8
GPIO0_D21	GPIO Expansion 0 IO[21]	3.0-V	PIN_AK8
GPIO0_D22	GPIO Expansion 0 IO[22]	3.0-V	PIN_AJ11
GPIO0_D23	GPIO Expansion 0 IO[23]	3.0-V	PIN_AK7
GPIO0_D24	GPIO Expansion 0 IO[24]	3.0-V	PIN_AJ5

GPIO0_D25	GPIO Expansion 0 IO[25]	3.0-V	PIN_AH12
GPIO0_D26	GPIO Expansion 0 IO[26]	3.0-V	PIN_AG10
GPIO0_D27	GPIO Expansion 0 IO[27]	3.0-V	PIN_AG13
GPIO0_D28	GPIO Expansion 0 IO[28]	3.0-V	PIN_AG9
GPIO0_D29	GPIO Expansion 0 IO[29]	3.0-V	PIN_AF11
GPIO0_D30	GPIO Expansion 0 IO[30]	3.0-V	PIN_AT9
GPIO0_D31	GPIO Expansion 0 IO[31]	3.0-V	PIN_AF10
GPIO0_D32	GPIO Expansion 0 IO[32]	3.0-V	PIN_AD10
GPIO0_D33	GPIO Expansion 0 IO[33]	3.0-V	PIN_AD9
GPIO0_D34	GPIO Expansion 0 IO[34]	3.0-V	PIN_AD12
GPIO0_D35	GPIO Expansion 0 IO[35]	3.0-V	PIN_AD13

Table 2–13 GPIO Expansion Header (JP4) Pin Assignments, Schematic Signal Names, and Functions

<i>Schematic Signal Name</i>	<i>Description</i>	<i>I/O Standard</i>	<i>Stratix IV GX Pin Number</i>
GPIO1_D0	GPIO Expansion 1 IO[0]	3.0-V	PIN_AW5
GPIO1_D1	GPIO Expansion 1 IO[1]	3.0-V	PIN_AW8
GPIO1_D2	GPIO Expansion 1 IO[2]	3.0-V	PIN_AW4
GPIO1_D3	GPIO Expansion 1 IO[3]	3.0-V	PIN_AV10
GPIO1_D4	GPIO Expansion 1 IO[4]	3.0-V	PIN_AV8
GPIO1_D5	GPIO Expansion 1 IO[5]	3.0-V	PIN_AW10
GPIO1_D6	GPIO Expansion 1 IO[6]	3.0-V	PIN_AU10
GPIO1_D7	GPIO Expansion 1 IO[7]	3.0-V	PIN_AU8
GPIO1_D8	GPIO Expansion 1 IO[8]	3.0-V	PIN_AP8
GPIO1_D9	GPIO Expansion 1 IO[9]	3.0-V	PIN_AT10
GPIO1_D10	GPIO Expansion 1 IO[10]	3.0-V	PIN_AU6
GPIO1_D11	GPIO Expansion 1 IO[11]	3.0-V	PIN_AT6
GPIO1_D12	GPIO Expansion 1 IO[12]	3.0-V	PIN_AU7
GPIO1_D13	GPIO Expansion 1 IO[13]	3.0-V	PIN_AR5
GPIO1_D14	GPIO Expansion 1 IO[14]	3.0-V	PIN_AP6
GPIO1_D15	GPIO Expansion 1 IO[15]	3.0-V	PIN_AT7
GPIO1_D16	GPIO Expansion 1 IO[16]	3.0-V	PIN_AN7
GPIO1_D17	GPIO Expansion 1 IO[17]	3.0-V	PIN_AN6
GPIO1_D18	GPIO Expansion 1 IO[18]	3.0-V	PIN_AL6
GPIO1_D19	GPIO Expansion 1 IO[19]	3.0-V	PIN_AM6
GPIO1_D20	GPIO Expansion 1 IO[20]	3.0-V	PIN_AL5
GPIO1_D21	GPIO Expansion 1 IO[21]	3.0-V	PIN_AL9
GPIO1_D22	GPIO Expansion 1 IO[22]	3.0-V	PIN_AK9
GPIO1_D23	GPIO Expansion 1 IO[23]	3.0-V	PIN_AJ6
GPIO1_D24	GPIO Expansion 1 IO[24]	3.0-V	PIN_AJ10
GPIO1_D25	GPIO Expansion 1 IO[25]	3.0-V	PIN_AH11

GPIO1_D26	GPIO Expansion 1 IO[26]	3.0-V	PIN_AH8
GPIO1_D27	GPIO Expansion 1 IO[27]	3.0-V	PIN_AH9
GPIO1_D28	GPIO Expansion 1 IO[28]	3.0-V	PIN_AG12
GPIO1_D29	GPIO Expansion 1 IO[29]	3.0-V	PIN_AH10
GPIO1_D30	GPIO Expansion 1 IO[30]	3.0-V	PIN_AF13
GPIO1_D31	GPIO Expansion 1 IO[31]	3.0-V	PIN_AE13
GPIO1_D32	GPIO Expansion 1 IO[32]	3.0-V	PIN_AE10
GPIO1_D33	GPIO Expansion 1 IO[33]	3.0-V	PIN_AP10
GPIO1_D34	GPIO Expansion 1 IO[34]	3.0-V	PIN_AE12
GPIO1_D35	GPIO Expansion 1 IO[35]	3.0-V	PIN_AE11

Table 2–14 External 14-pin Expansion Header (JP6) Pin Assignments, Schematic Signal Names, and Functions

<i>Schematic Signal Name</i>	<i>Description</i>	<i>I/O Standard</i>	<i>Stratix IV GX Pin Number</i>
GPIO0_D0	GPIO Expansion 0 IO[0](Clock In)	3.0-V or LVDS	PIN_AF6
GPIO0_D1	GPIO Expansion 0 IO[1]	3.0-V	PIN_AU9
GPIO0_D2	GPIO Expansion 0 IO[2](Clock In)	3.0-V or LVDS	PIN_AE5
GPIO0_D3	GPIO Expansion 0 IO[3]	3.0-V	PIN_AR8
GPIO0_D4	GPIO Expansion 0 IO[4]	3.0-V	PIN_AN9
GPIO0_D5	GPIO Expansion 0 IO[5]	3.0-V	PIN_AP9
GPIO0_D6	GPIO Expansion 0 IO[6]	3.0-V	PIN_AV5

2.7 DDR2 SO-DIMM

Two 200-pin DDR2 SO-DIMM sockets are provided as a flexible and efficient form-factor volatile memory for user applications. The two DDR2 SODIMM socket is wired to support a maximum capacity of 8GB with a 64-bit data bus. Using differential DQS signaling for the DDR2 SDRAM interfaces, it is capable of running at or above 400MHz memory clock for a maximum theoretical bandwidth of over 102Gbps. **Figure 2–20** shows the connections between the DDR2 SO-DIMM socket and Stratix IV GX device. The pin assignments are listed in **Table 2–15** and **Table 2–16**.

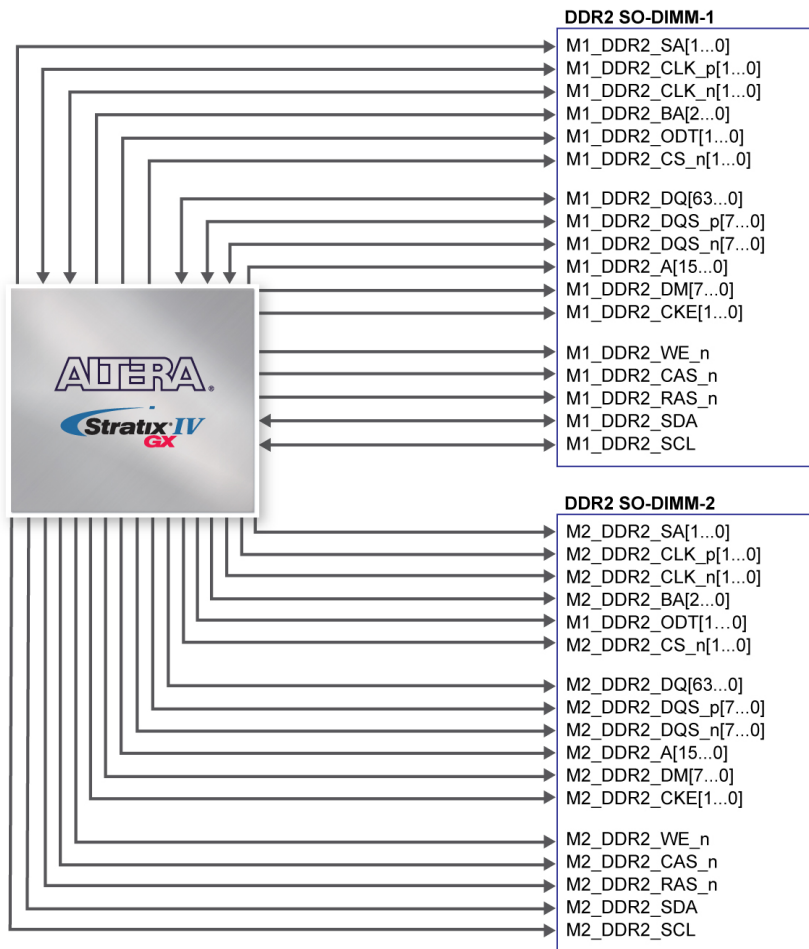

Figure 2–20 Connection between the DDR2 and Stratix IV GX FPGA

Table 2–15 DDR2-SO-DIMM-1 Pin Assignments, Schematic Signal Names, and Functions

<i>Schematic Signal Name</i>	<i>Description</i>	<i>I/O Standard</i>	<i>Stratix IV GX Pin Number</i>
M1_DDR2_DQ4	DDR Data [4]	SSTL-18 Class I	PIN_AW34
M1_DDR2_DQ0	DDR Data [0]	SSTL-18 Class I	PIN_AV32
M1_DDR2_DQ5	DDR Data [5]	SSTL-18 Class I	PIN_AW33
M1_DDR2_DQ1	DDR Data [1]	SSTL-18 Class I	PIN_AV31
M1_DDR2_DM0	DDR2 Data Mask [0]	SSTL-18 Class I	PIN_AW31
M1_DDR2_DQS_n0	DDR2 Data Strobe n[0]	Differential 1.8-V SSTL Class I	PIN_AW30
M1_DDR2_DQS_p0	DDR2 Data Strobe p[0]	Differential 1.8-V SSTL Class I	PIN_AV29
M1_DDR2_DQ6	DDR Data [6]	SSTL-18 Class I	PIN_AW28
M1_DDR2_DQ7	DDR Data [7]	SSTL-18 Class I	PIN_AW27
M1_DDR2_DQ2	DDR Data [2]	SSTL-18 Class I	PIN_AW29

M1_DDR2_DQ3	DDR Data [3]	SSTL-18 Class I	PIN_AV28
M1_DDR2_DQ12	DDR Data [12]	SSTL-18 Class I	PIN_AM25
M1_DDR2_DQ13	DDR Data [13]	SSTL-18 Class I	PIN_AN25
M1_DDR2_DQ8	DDR Data [8]	SSTL-18 Class I	PIN_AP25
M1_DDR2_DQ9	DDR Data [9]	SSTL-18 Class I	PIN_AV26
M1_DDR2_DM1	DDR2 Data Mask [1]	SSTL-18 Class I	PIN_AW26
M1_DDR2_DQS_n1	DDR2 Data Strobe n[1]	Differential 1.8-V SSTL Class I	PIN_AU26
M1_DDR2_CLK_p0	Clock p0 for DDR2	Differential 1.8-V SSTL Class I	PIN_AP28
M1_DDR2_DQS_p1	DDR2 Data Strobe p[1]	Differential 1.8-V SSTL Class I	PIN_AT26
M1_DDR2_CLK_n0	Clock n0 for DDR2	Differential 1.8-V SSTL Class I	PIN_AR28
M1_DDR2_DQ10	DDR Data [10]	SSTL-18 Class I	PIN_AU25
M1_DDR2_DQ14	DDR Data [14]	SSTL-18 Class I	PIN_AR25
M1_DDR2_DQ11	DDR Data [11]	SSTL-18 Class I	PIN_AT25
M1_DDR2_DQ15	DDR Data [15]	SSTL-18 Class I	PIN_AN24
M1_DDR2_DQ16	DDR Data [16]	SSTL-18 Class I	PIN_AN23
M1_DDR2_DQ20	DDR Data [20]	SSTL-18 Class I	PIN_AM23
M1_DDR2_DQ17	DDR Data [17]	SSTL-18 Class I	PIN_AP23
M1_DDR2_DQ21	DDR Data [21]	SSTL-18 Class I	PIN_AR23
M1_DDR2_DQS_n2	DDR2 Data Strobe n[2]	Differential 1.8-V SSTL Class I	PIN_AU24
M1_DDR2_DQS_p2	DDR2 Data Strobe p[2]	Differential 1.8-V SSTL Class I	PIN_AT24
M1_DDR2_DM2	DDR2 Data Mask [2]	SSTL-18 Class I	PIN_AU23
M1_DDR2_DQ18	DDR Data [18]	SSTL-18 Class I	PIN_AL22
M1_DDR2_DQ22	DDR Data [22]	SSTL-18 Class I	PIN_AT23
M1_DDR2_DQ19	DDR Data [19]	SSTL-18 Class I	PIN_AM22
M1_DDR2_DQ23	DDR Data [23]	SSTL-18 Class I	PIN_AL21
M1_DDR2_DQ24	DDR Data [24]	SSTL-18 Class I	PIN_AJ22
M1_DDR2_DQ28	DDR Data [28]	SSTL-18 Class I	PIN_AK24
M1_DDR2_DQ25	DDR Data [25]	SSTL-18 Class I	PIN_AH23
M1_DDR2_DQ29	DDR Data [29]	SSTL-18 Class I	PIN_AJ23
M1_DDR2_DM3	DDR2 Data Mask [3]	SSTL-18 Class I	PIN_AH22
M1_DDR2_DQS_n3	DDR2 Data Strobe n[3]	Differential 1.8-V SSTL Class I	PIN_AL23
M1_DDR2_DQS_p3	DDR2 Data Strobe p[3]	Differential 1.8-V SSTL Class I	PIN_AK23
M1_DDR2_DQ26	DDR Data [26]	SSTL-18 Class I	PIN_AF22
M1_DDR2_DQ30	DDR Data [30]	SSTL-18 Class I	PIN_AF23
M1_DDR2_DQ27	DDR Data [27]	SSTL-18 Class I	PIN_AE23
M1_DDR2_DQ31	DDR Data [31]	SSTL-18 Class I	PIN_AE22

M1_DDR2_CKE0	Clock Enable pin 0 for DDR2	SSTL-18 Class I	PIN_AT28
M1_DDR2_CKE1	Clock Enable pin 1 for DDR2	SSTL-18 Class I	PIN_AK27
M1_DDR2_A15	DDR2 Address [15]	SSTL-18 Class I	PIN_AT29
M1_DDR2_BA2	DDR2 Bank Address [2]	SSTL-18 Class I	PIN_AP27
M1_DDR2_A14	DDR2 Address [14]	SSTL-18 Class I	PIN_AU29
M1_DDR2_A12	DDR2 Address [12]	SSTL-18 Class I	PIN_AP26
M1_DDR2_A11	DDR2 Address [11]	SSTL-18 Class I	PIN_AU28
M1_DDR2_A9	DDR2 Address [9]	SSTL-18 Class I	PIN_AN27
M1_DDR2_A7	DDR2 Address [7]	SSTL-18 Class I	PIN_AT27
M1_DDR2_A8	DDR2 Address [8]	SSTL-18 Class I	PIN_AL27
M1_DDR2_A6	DDR2 Address [6]	SSTL-18 Class I	PIN_AU27
M1_DDR2_A5	DDR2 Address [5]	SSTL-18 Class I	PIN_AK26
M1_DDR2_A4	DDR2 Address [4]	SSTL-18 Class I	PIN_AN26
M1_DDR2_A3	DDR2 Address [3]	SSTL-18 Class I	PIN_AM26
M1_DDR2_A2	DDR2 Address [2]	SSTL-18 Class I	PIN_AW23
M1_DDR2_A1	DDR2 Address [1]	SSTL-18 Class I	PIN_AL25
M1_DDR2_A0	DDR2 Address [0]	SSTL-18 Class I	PIN_AV23
M1_DDR2_A10	DDR2 Address [10]	SSTL-18 Class I	PIN_AJ26
M1_DDR2_BA1	DDR2 Bank Address [1]	SSTL-18 Class I	PIN_AD25
M1_DDR2_BA0	DDR2 Bank Address [0]	SSTL-18 Class I	PIN_AH26
M1_DDR2_RAS_n	DDR2 Row Address Strobe	SSTL-18 Class I	PIN_AE21
M1_DDR2_WE_n	DDR2 Write Enable	SSTL-18 Class I	PIN_AK25
M1_DDR2_CS_n0	DDR2 Chip Select [0]	SSTL-18 Class I	PIN_AG21
M1_DDR2_CAS_n	DDR2 Column Address Strobe	SSTL-18 Class I	PIN_AJ25
M1_DDR2_ODT0	DDR2 On Die Termination[0]	SSTL-18 Class I	PIN_AG20
M1_DDR2_CS_n1	DDR2 Chip Select [1]	SSTL-18 Class I	PIN_AE25
M1_DDR2_A13	DDR2 Address [13]	SSTL-18 Class I	PIN_AD21
M1_DDR2_ODT1	DDR2 On Die Termination[1]	SSTL-18 Class I	PIN_AE24
M1_DDR2_DQ32	DDR Data [32]	SSTL-18 Class I	PIN_AK17
M1_DDR2_DQ36	DDR Data [36]	SSTL-18 Class I	PIN_AG16
M1_DDR2_DQ33	DDR Data [33]	SSTL-18 Class I	PIN_AM17
M1_DDR2_DQ37	DDR Data [37]	SSTL-18 Class I	PIN_AH17
M1_DDR2_DQS_n4	DDR2 Data Strobe n[4]	Differential 1.8-V SSTL Class I I	PIN_AL16
M1_DDR2_DM4	DDR2 Data Mask [4]	SSTL-18 Class I	PIN_AL17
M1_DDR2_DQS_p4	DDR2 Data Strobe p[4]	Differential 1.8-V SSTL Class I	PIN_AK16
M1_DDR2_DQ38	DDR Data [38]	SSTL-18 Class I	PIN_AF17
M1_DDR2_DQ34	DDR Data [34]	SSTL-18 Class I	PIN_AH16
M1_DDR2_DQ39	DDR Data [39]	SSTL-18 Class I	PIN_AE17
M1_DDR2_DQ35	DDR Data [35]	SSTL-18 Class I	PIN_AJ16
M1_DDR2_DQ44	DDR Data [44]	SSTL-18 Class I	PIN_AN17
M1_DDR2_DQ40	DDR Data [40]	SSTL-18 Class I	PIN_AR17

M1_DDR2_DQ45	DDR Data [45]	SSTL-18 Class I	PIN_AP17
M1_DDR2_DQ41	DDR Data [41]	SSTL-18 Class I	PIN_AN16
M1_DDR2_DQS_n5	DDR2 Data Strobe n[5]	Differential 1.8-V SSTL Class I	PIN_AR16
M1_DDR2_DM5	DDR2 Data Mask [5]	SSTL-18 Class I	PIN_AT16
M1_DDR2_DQS_p5	DDR2 Data Strobe p[5]	Differential 1.8-V SSTL Class I	PIN_AP16
M1_DDR2_DQ42	DDR Data [42]	SSTL-18 Class I	PIN_AU16
M1_DDR2_DQ46	DDR Data [46]	SSTL-18 Class I	PIN_AU15
M1_DDR2_DQ43	DDR Data [43]	SSTL-18 Class I	PIN_AW16
M1_DDR2_DQ47	DDR Data [47]	SSTL-18 Class I	PIN_AT15
M1_DDR2_DQ48	DDR Data [48]	SSTL-18 Class I	PIN_AW11
M1_DDR2_DQ52	DDR Data [52]	SSTL-18 Class I	PIN_AW14
M1_DDR2_DQ49	DDR Data [49]	SSTL-18 Class I	PIN_AW12
M1_DDR2_DQ53	DDR Data [53]	SSTL-18 Class I	PIN_AV14
M1_DDR2_CLK_p1	Clock p1 for DDR2	Differential 1.8-V SSTL Class I	PIN_AE20
M1_DDR2_CLK_n1	Clock n1 for DDR2	Differential 1.8-V SSTL Class I	PIN_AF20
M1_DDR2_DQS_n6	DDR2 Data Strobe n[6]	Differential 1.8-V SSTL Class I	PIN_AW13
M1_DDR2_DQS_p6	DDR2 Data Strobe n[6]	Differential 1.8-V SSTL Class I	PIN_AV13
M1_DDR2_DM6	DDR2 Data Mask [6]	SSTL-18 Class I	PIN_AU14
M1_DDR2_DQ50	DDR Data [50]	SSTL-18 Class I	PIN_AT14
M1_DDR2_DQ54	DDR Data [54]	SSTL-18 Class I	PIN_AU11
M1_DDR2_DQ51	DDR Data [51]	SSTL-18 Class I	PIN_AU12
M1_DDR2_DQ55	DDR Data [55]	SSTL-18 Class I	PIN_AT12
M1_DDR2_DQ56	DDR Data [56]	SSTL-18 Class I	PIN_AP13
M1_DDR2_DQ60	DDR Data [60]	SSTL-18 Class I	PIN_AR14
M1_DDR2_DQ57	DDR Data [57]	SSTL-18 Class I	PIN_AN14
M1_DDR2_DQ61	DDR Data [61]	SSTL-18 Class I	PIN_AP14
M1_DDR2_DM7	DDR2 Data Mask [7]	SSTL-18 Class I	PIN_AN13
M1_DDR2_DQS_n7	DDR2 Data Strobe n[7]	Differential 1.8-V SSTL Class I	PIN_AT13
M1_DDR2_DQS_p7	DDR2 Data Strobe p[7]	Differential 1.8-V SSTL Class I	PIN_AR13
M1_DDR2_DQ58	DDR Data [58]	SSTL-18 Class I	PIN_AL15
M1_DDR2_DQ59	DDR Data [59]	SSTL-18 Class I	PIN_AM14
M1_DDR2_DQ62	DDR Data [62]	SSTL-18 Class I	PIN_AL14
M1_DDR2_DQ63	DDR Data [63]	SSTL-18 Class I	PIN_AL13
M1_DDR2_SDA	DDR2 I2C Data	1.8-V	PIN_AG24
M1_DDR2_SCL	DDR2 I2C Clock	1.8-V	PIN_AH24
M1_DDR2_SA0	DDR2 Presence-detect address	1.8-V	PIN_AV25

	input [0]		
M1_DDR2_SA1	DDR2 Presence-detect address input [1]	1.8-V	PIN_AW25

Table 2–16 DDR2-SO-DIMM-2 Pin Assignments, Schematic Signal Names, and Functions

<i>Schematic Signal Name</i>	<i>Description</i>	<i>I/O Standard</i>	<i>Stratix IV GX Pin Number</i>
M2_DDR2_DQ4	DDR Data [4]	SSTL-18 Class I	PIN_J12
M2_DDR2_DQ0	DDR Data [0]	SSTL-18 Class I	PIN_F12
M2_DDR2_DQ5	DDR Data [5]	SSTL-18 Class I	PIN_J13
M2_DDR2_DQ1	DDR Data [1]	SSTL-18 Class I	PIN_H13
M2_DDR2_DM0	DDR2 Data Mask [0]	SSTL-18 Class I	PIN_H14
M2_DDR2_DQS_n0	DDR2 Data Strobe n[0]	Differential 1.8-V SSTL Class I	PIN_E13
M2_DDR2_DQS_p0	DDR2 Data Strobe p[0]	Differential 1.8-V SSTL Class I	PIN_F13
M2_DDR2_DQ6	DDR Data [6]	SSTL-18 Class I	PIN_G14
M2_DDR2_DQ7	DDR Data [7]	SSTL-18 Class I	PIN_D13
M2_DDR2_DQ2	DDR Data [2]	SSTL-18 Class I	PIN_E14
M2_DDR2_DQ3	DDR Data [3]	SSTL-18 Class I	PIN_F14
M2_DDR2_DQ12	DDR Data [12]	SSTL-18 Class I	PIN_P16
M2_DDR2_DQ13	DDR Data [13]	SSTL-18 Class I	PIN_N16
M2_DDR2_DQ8	DDR Data [8]	SSTL-18 Class I	PIN_P17
M2_DDR2_DQ9	DDR Data [9]	SSTL-18 Class I	PIN_N17
M2_DDR2_DM1	DDR2 Data Mask [1]	SSTL-18 Class I	PIN_M17
M2_DDR2_DQS_n1	DDR2 Data Strobe n[1]	Differential 1.8-V SSTL Class I	PIN_J16
M2_DDR2_CLK_p0	Clock p0 for DDR2	Differential 1.8-V SSTL Class I	PIN_L13
M2_DDR2_DQS_p1	DDR2 Data Strobe p[1]	Differential 1.8-V SSTL Class I	PIN_K16
M2_DDR2_CLK_n0	Clock n0 for DDR2	Differential 1.8-V SSTL Class I	PIN_K13
M2_DDR2_DQ10	DDR Data [10]	SSTL-18 Class I	PIN_L16
M2_DDR2_DQ14	DDR Data [14]	SSTL-18 Class I	PIN_J17
M2_DDR2_DQ11	DDR Data [11]	SSTL-18 Class I	PIN_K17
M2_DDR2_DQ15	DDR Data [15]	SSTL-18 Class I	PIN_H17
M2_DDR2_DQ16	DDR Data [16]	SSTL-18 Class I	PIN_B16
M2_DDR2_DQ20	DDR Data [20]	SSTL-18 Class I	PIN_C16
M2_DDR2_DQ17	DDR Data [17]	SSTL-18 Class I	PIN_A16
M2_DDR2_DQ21	DDR Data [21]	SSTL-18 Class I	PIN_E16
M2_DDR2_DQS_n2	DDR2 Data Strobe n[2]	Differential 1.8-V SSTL Class I	PIN_C15

M2_DDR2_DQS_p2	DDR2 Data Strobe p[2]	Differential 1.8-V SSTL Class I	PIN_D15
M2_DDR2_DM2	DDR2 Data Mask [2]	SSTL-18 Class I	PIN_G15
M2_DDR2_DQ18	DDR Data [18]	SSTL-18 Class I	PIN_F15
M2_DDR2_DQ22	DDR Data [22]	SSTL-18 Class I	PIN_G16
M2_DDR2_DQ19	DDR Data [19]	SSTL-18 Class I	PIN_D16
M2_DDR2_DQ23	DDR Data [23]	SSTL-18 Class I	PIN_G17
M2_DDR2_DQ24	DDR Data [24]	SSTL-18 Class I	PIN_C17
M2_DDR2_DQ28	DDR Data [28]	SSTL-18 Class I	PIN_C18
M2_DDR2_DQ25	DDR Data [25]	SSTL-18 Class I	PIN_E17
M2_DDR2_DQ29	DDR Data [29]	SSTL-18 Class I	PIN_D18
M2_DDR2_DM3	DDR2 Data Mask [3]	SSTL-18 Class I	PIN_F17
M2_DDR2_DQS_n3	DDR2 Data Strobe n[3]	Differential 1.8-V SSTL Class I	PIN_F18
M2_DDR2_DQS_p3	DDR2 Data Strobe p[3]	Differential 1.8-V SSTL Class I	PIN_G18
M2_DDR2_DQ26	DDR Data [26]	SSTL-18 Class I	PIN_F19
M2_DDR2_DQ30	DDR Data [30]	SSTL-18 Class I	PIN_F20
M2_DDR2_DQ27	DDR Data [27]	SSTL-18 Class I	PIN_G19
M2_DDR2_DQ31	DDR Data [31]	SSTL-18 Class I	PIN_G20
M2_DDR2_CKE0	Clock Enable pin 0 for DDR2	SSTL-18 Class I	PIN_D11
M2_DDR2_CKE1	Clock Enable pin 1 for DDR2	SSTL-18 Class I	PIN_K12
M2_DDR2_A15	DDR2 Address [15]	SSTL-18 Class I	PIN_M13
M2_DDR2_BA2	DDR2 Bank Address [2]	SSTL-18 Class I	PIN_B10
M2_DDR2_A14	DDR2 Address [14]	SSTL-18 Class I	PIN_K14
M2_DDR2_A12	DDR2 Address [12]	SSTL-18 Class I	PIN_N15
M2_DDR2_A11	DDR2 Address [11]	SSTL-18 Class I	PIN_L14
M2_DDR2_A9	DDR2 Address [9]	SSTL-18 Class I	PIN_M14
M2_DDR2_A7	DDR2 Address [7]	SSTL-18 Class I	PIN_N13
M2_DDR2_A8	DDR2 Address [8]	SSTL-18 Class I	PIN_A10
M2_DDR2_A6	DDR2 Address [6]	SSTL-18 Class I	PIN_A11
M2_DDR2_A5	DDR2 Address [5]	SSTL-18 Class I	PIN_C11
M2_DDR2_A4	DDR2 Address [4]	SSTL-18 Class I	PIN_C13
M2_DDR2_A3	DDR2 Address [3]	SSTL-18 Class I	PIN_R14
M2_DDR2_A2	DDR2 Address [2]	SSTL-18 Class I	PIN_D14
M2_DDR2_A1	DDR2 Address [1]	SSTL-18 Class I	PIN_B11
M2_DDR2_A0	DDR2 Address [0]	SSTL-18 Class I	PIN_B14
M2_DDR2_A10	DDR2 Address [10]	SSTL-18 Class I	PIN_R18
M2_DDR2_BA1	DDR2 Bank Address [1]	SSTL-18 Class I	PIN_C14
M2_DDR2_BA0	DDR2 Bank Address [0]	SSTL-18 Class I	PIN_C12
M2_DDR2_RAS_n	DDR2 Row Address Strobe	SSTL-18 Class I	PIN_J18
M2_DDR2_WE_n	DDR2 Write Enable	SSTL-18 Class I	PIN_P18
M2_DDR2_CS_n0	DDR2 Chip Select [0]	SSTL-18 Class I	PIN_H19

M2_DDR2_CAS_n	DDR2 Column Address Strobe	SSTL-18 Class I	PIN_A13
M2_DDR2_ODT0	DDR2 On Die Termination[0]	SSTL-18 Class I	PIN_D19
M2_DDR2_CS_n1	DDR2 Chip Select [1]	SSTL-18 Class I	PIN_B13
M2_DDR2_A13	DDR2 Address [13]	SSTL-18 Class I	PIN_C19
M2_DDR2_ODT1	DDR2 On Die Termination[1]	SSTL-18 Class I	PIN_A14
M2_DDR2_DQ32	DDR Data [32]	SSTL-18 Class I	PIN_N22
M2_DDR2_DQ36	DDR Data [36]	SSTL-18 Class I	PIN_R22
M2_DDR2_DQ33	DDR Data [33]	SSTL-18 Class I	PIN_M23
M2_DDR2_DQ37	DDR Data [37]	SSTL-18 Class I	PIN_P22
M2_DDR2_DQS_n4	DDR2 Data Strobe n[4]	Differential 1.8-V SSTL Class I	PIN_K23
M2_DDR2_DM4	DDR2 Data Mask [4]	SSTL-18 Class I	PIN_P23
M2_DDR2_DQS_p4	DDR2 Data Strobe p[4]	Differential 1.8-V SSTL Class I	PIN_L23
M2_DDR2_DQ38	DDR Data [38]	SSTL-18 Class I	PIN_M24
M2_DDR2_DQ34	DDR Data [34]	SSTL-18 Class I	PIN_K24
M2_DDR2_DQ39	DDR Data [39]	SSTL-18 Class I	PIN_J24
M2_DDR2_DQ35	DDR Data [35]	SSTL-18 Class I	PIN_J25
M2_DDR2_DQ44	DDR Data [44]	SSTL-18 Class I	PIN_G24
M2_DDR2_DQ40	DDR Data [40]	SSTL-18 Class I	PIN_G25
M2_DDR2_DQ45	DDR Data [45]	SSTL-18 Class I	PIN_F24
M2_DDR2_DQ41	DDR Data [41]	SSTL-18 Class I	PIN_C25
M2_DDR2_DQS_n5	DDR2 Data Strobe n[5]	Differential 1.8-V SSTL Class I	PIN_E25
M2_DDR2_DM5	DDR2 Data Mask [5]	SSTL-18 Class I	PIN_B25
M2_DDR2_DQS_p5	DDR2 Data Strobe p[5]	Differential 1.8-V SSTL Class I	PIN_F25
M2_DDR2_DQ42	DDR Data [42]	SSTL-18 Class I	PIN_A26
M2_DDR2_DQ46	DDR Data [46]	SSTL-18 Class I	PIN_D25
M2_DDR2_DQ43	DDR Data [43]	SSTL-18 Class I	PIN_C26
M2_DDR2_DQ47	DDR Data [47]	SSTL-18 Class I	PIN_D26
M2_DDR2_DQ48	DDR Data [48]	SSTL-18 Class I	PIN_F27
M2_DDR2_DQ52	DDR Data [52]	SSTL-18 Class I	PIN_H26
M2_DDR2_DQ49	DDR Data [49]	SSTL-18 Class I	PIN_G27
M2_DDR2_DQ53	DDR Data [53]	SSTL-18 Class I	PIN_J26
M2_DDR2_CLK_p1	Clock p1 for DDR2	Differential 1.8-V SSTL Class I	PIN_B17
M2_DDR2_CLK_n1	Clock n1 for DDR2	Differential 1.8-V SSTL Class I	PIN_A17
M2_DDR2_DQS_n6	DDR2 Data Strobe n[6]	Differential 1.8-V SSTL Class I	PIN_D29
M2_DDR2_DQS_p6	DDR2 Data Strobe n[6]	Differential 1.8-V SSTL Class I	PIN_E29
M2_DDR2_DM6	DDR2 Data Mask [6]	SSTL-18 Class I	PIN_D28

M2_DDR2_DQ50	DDR Data [50]	SSTL-18 Class I	PIN_F28
M2_DDR2_DQ54	DDR Data [54]	SSTL-18 Class I	PIN_E28
M2_DDR2_DQ51	DDR Data [51]	SSTL-18 Class I	PIN_H28
M2_DDR2_DQ55	DDR Data [55]	SSTL-18 Class I	PIN_G29
M2_DDR2_DQ56	DDR Data [56]	SSTL-18 Class I	PIN_C29
M2_DDR2_DQ60	DDR Data [60]	SSTL-18 Class I	PIN_A27
M2_DDR2_DQ57	DDR Data [57]	SSTL-18 Class I	PIN_A31
M2_DDR2_DQ61	DDR Data [61]	SSTL-18 Class I	PIN_A28
M2_DDR2_DM7	DDR2 Data Mask [7]	SSTL-18 Class I	PIN_C30
M2_DDR2_DQS_n7	DDR2 Data Strobe n[7]	Differential 1.8-V SSTL Class I	PIN_B28
M2_DDR2_DQS_p7	DDR2 Data Strobe p[7]	Differential 1.8-V SSTL Class I	PIN_C28
M2_DDR2_DQ58	DDR Data [58]	SSTL-18 Class I	PIN_C27
M2_DDR2_DQ59	DDR Data [59]	SSTL-18 Class I	PIN_D27
M2_DDR2_DQ62	DDR Data [62]	SSTL-18 Class I	PIN_B29
M2_DDR2_DQ63	DDR Data [63]	SSTL-18 Class I	PIN_B31
M2_DDR2_SDA	DDR2 I2C Data	1.8-V	PIN_J15
M2_DDR2_SCL	DDR2 I2C Clock	1.8-V	PIN_K15
M2_DDR2_SA0	DDR2 Presence-detect address input [0]	1.8-V	PIN_A18
M2_DDR2_SA1	DDR2 Presence-detect address input [1]	1.8-V	PIN_B19

2.8 USB OTG

The DE4 board provides both USB host and device interfaces using Philips ISP1761 single-chip Hi-Speed Universal Serial Bus (USB) On-The-Go (OTG) Controller. The host and device controllers are compliant with the Universal Serial Bus Specification Rev. 2.0, supporting data transfer at high-speed (480 Mbit/s), full-speed (12 Mbit/s) and low-speed (1.5 Mbit/s). **Figure 2–21** shows the connection between the USB OTG and Stratix IV GX device. The ISP1761 has three USB ports. Port 1 can be configured as a downstream port, an upstream port or an OTG port; ports 2 and 3 are always configured as downstream ports. If the port 1 is configured as an OTG port, users can use SW4 to specify host or peripheral role, as listed in **Table 2–17**. The pin assignments for the associated interface are listed in **Table 2–18**.

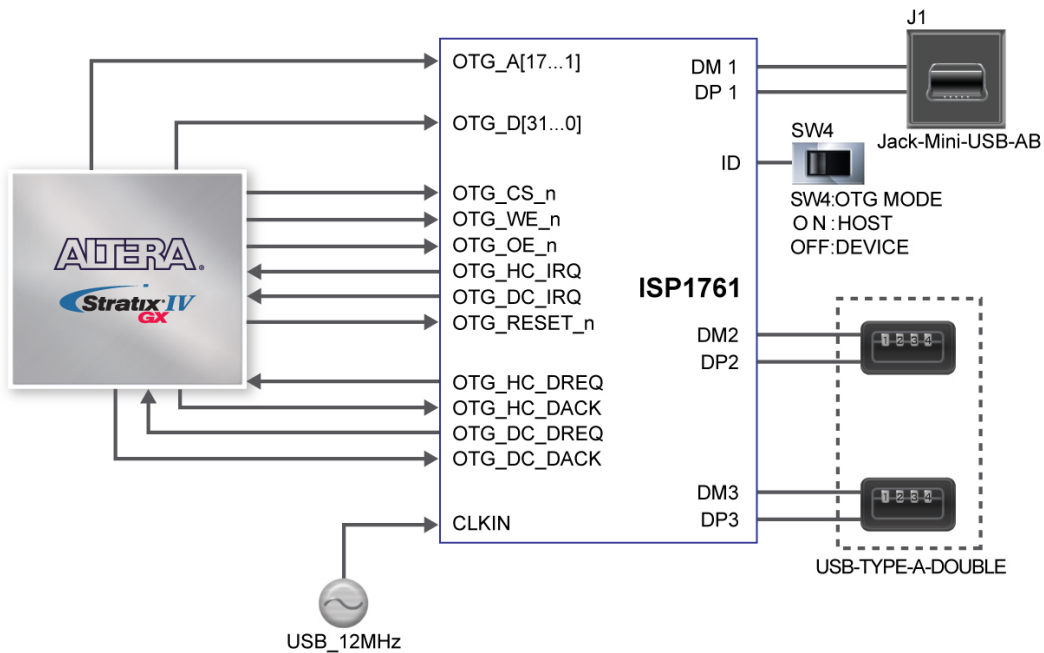

Figure 2–21 Connections between the USB OTG and Stratix IV GX device

Detailed information of the ISP1761 device can be found in its datasheet and programming guide; both documents are available from the manufacturer’s web site, or in the *Datasheet/USB* folder of the *DE4 System CD*. Two complete examples for host and device applications each, can be found in Sections 5.1 and 5.2. These demonstrations provide software drivers for the Nios II processor.

Table 2–17 The default host or peripheral setting for port 1 of the ISP1761

<i>SW4 Setting</i>	<i>Connectors</i>
ON	Port 1 set to host
OFF	Port 1 set to device

Table 2–18 USB 2.0 OTG Pin Assignments, Schematic Signal Names, and Functions

<i>Schematic Signal Name</i>	<i>Description</i>	<i>I/O Standard</i>	<i>Stratix IV GX Pin Number</i>
OTG_A1	OTG Address [1]	1.8-V	PIN_K26
OTG_A2	OTG Address [2]	1.8-V	PIN_P25
OTG_A3	OTG Address [3]	1.8-V	PIN_N25
OTG_A4	OTG Address [4]	1.8-V	PIN_R24
OTG_A5	OTG Address [5]	1.8-V	PIN_P24
OTG_A6	OTG Address [6]	1.8-V	PIN_M25
OTG_A7	OTG Address [7]	1.8-V	PIN_L25
OTG_A8	OTG Address [8]	1.8-V	PIN_N23

OTG_A9	OTG Address [9]	1.8-V	PIN_K28
OTG_A10	OTG Address [10]	1.8-V	PIN_A29
OTG_A11	OTG Address [11]	1.8-V	PIN_J27
OTG_A12	OTG Address [12]	1.8-V	PIN_G26
OTG_A13	OTG Address [13]	1.8-V	PIN_F26
OTG_A14	OTG Address [14]	1.8-V	PIN_G28
OTG_A15	OTG Address [15]	1.8-V	PIN_B26
OTG_A16	OTG Address [16]	1.8-V	PIN_D17
OTG_A17	OTG Address [17]	1.8-V	PIN_F16
OTG_D0	OTG Data [0]	1.8-V	PIN_AF16
OTG_D1	OTG Data [1]	1.8-V	PIN_AJ14
OTG_D2	OTG Data [2]	1.8-V	PIN_AD15
OTG_D3	OTG Data [3]	1.8-V	PIN_AE15
OTG_D4	OTG Data [4]	1.8-V	PIN_AE16
OTG_D5	OTG Data [5]	1.8-V	PIN_AH14
OTG_D6	OTG Data [6]	1.8-V	PIN_AM13
OTG_D7	OTG Data [7]	1.8-V	PIN_AN15
OTG_D8	OTG Data [8]	1.8-V	PIN_AP15
OTG_D9	OTG Data [9]	1.8-V	PIN_AG18
OTG_D10	OTG Data [10]	1.8-V	PIN_AG19
OTG_D11	OTG Data [11]	1.8-V	PIN_AM19
OTG_D12	OTG Data [12]	1.8-V	PIN_AN19
OTG_D13	OTG Data [13]	1.8-V	PIN_AV16
OTG_D14	OTG Data [14]	1.8-V	PIN_AT17
OTG_D15	OTG Data [15]	1.8-V	PIN_AV17
OTG_D16	OTG Data [16]	1.8-V	PIN_AU17
OTG_D17	OTG Data [17]	1.8-V	PIN_AW18
OTG_D18	OTG Data [18]	1.8-V	PIN_AT18
OTG_D19	OTG Data [19]	1.8-V	PIN_AU18
OTG_D20	OTG Data [20]	1.8-V	PIN_AR19
OTG_D21	OTG Data [21]	1.8-V	PIN_AW20
OTG_D22	OTG Data [22]	1.8-V	PIN_AW21
OTG_D23	OTG Data [23]	1.8-V	PIN_AF19
OTG_D24	OTG Data [24]	1.8-V	PIN_AE19
OTG_D25	OTG Data [25]	1.8-V	PIN_AE18
OTG_D26	OTG Data [26]	1.8-V	PIN_AD19
OTG_D27	OTG Data [27]	1.8-V	PIN_G13
OTG_D28	OTG Data [28]	1.8-V	PIN_M16
OTG_D29	OTG Data [29]	1.8-V	PIN_M27
OTG_D30	OTG Data [30]	1.8-V	PIN_K27
OTG_D31	OTG Data [31]	1.8-V	PIN_L26
OTG_CS_n	OTG Chip Select	1.8-V	PIN_P19
OTG_WE_n	OTG Write Enable	1.8-V	PIN_AR22

OTG_OE_n	OTG Output Enable	1.8-V	PIN_N19
OTG_HC_IRQ	OTG Host Controller IRQ	1.8-V	PIN_AJ20
OTG_DC_IRQ	OTG Peripheral Controller IRQ	1.8-V	PIN_AT22
OTG_RESET_n	OTG Reset	1.8-V	PIN_AU22
OTG_HC_DREQ	OTG DMA Controller request for Host Controller	1.8-V	PIN_AN21
OTG_HC_DACK	OTG DMA Controller request Acknowledgement	1.8-V	PIN_AT21
OTG_DC_DREQ	OTG DMA Controller request for Peripheral Controller	1.8-V	PIN_AP21
OTG_DC_DACK	Peripheral Controller DMA request acknowledgement	1.8-V	PIN_AH20
USB_12MHZ	OTG CLK input	-	-
PSW1	Power Switch for port 1	-	-
DM1	Downstream data minus port 1	-	-
DP1	Downstream data plus port 1	-	-
USB_ID	ID input to detect the default	-	-
PSW2	Power Switch for port 2	-	-
DM2	Downstream data minus port 2	-	-
DP2	Downstream data plus port 2	-	-
PSW3	Power Switch for port 3	-	-
DM3	Downstream data minus port 3	-	-
DP3	Downstream data plus port 3	-	-

2.9 SD Card

The DE4 is equipped with a SD card socket and can be accessed as an optional external memory in both SPI and 4-bit SD mode. **Table 2–19** lists the pin assignments of the SD card socket with Stratix IV GX FPGA. The connection between the SD card and Stratix IV GX device is presented in **Figure 2–22**.

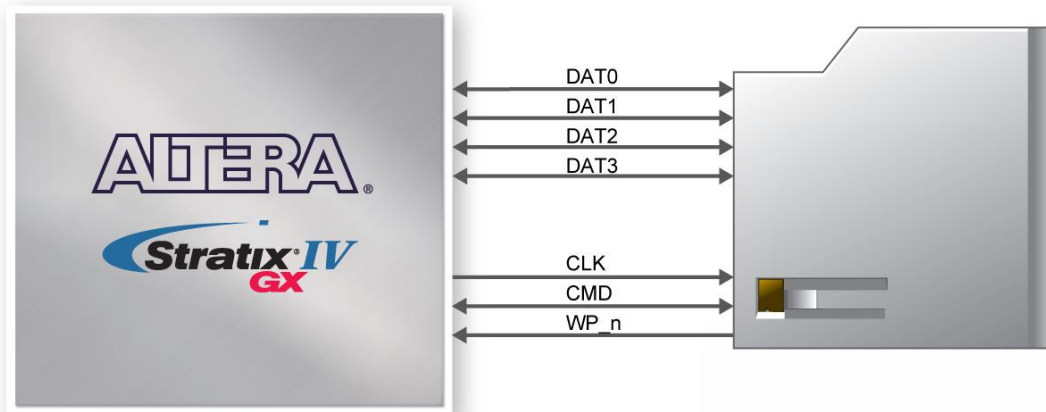

Figure 2–22 Connections between the SD card and Stratix IV GX

Table 2–19 SD Card Socket Pin Assignments, Schematic Signal Names, and Functions

Schematic Signal Name	Description	I/O Standard	Stratix IV GX Pin Number
E_SD_CLK	Clock for SD	1.8-V	PIN_AT19
SD_WP_n	Write protection for SD	1.8-V	PIN_AH18
E_SD_DAT0	Data bit 0 for SD	1.8-V	PIN_AR20
E_SD_DAT1	Data bit 1 for SD	1.8-V	PIN_AT20
E_SD_DAT2	Data bit 2 for SD	1.8-V	PIN_AU19
E_SD_DAT3	Data bit 3 for SD	1.8-V	PIN_AU20
E_SD_CMD	Command for SD	1.8-V	PIN_AV20

2.10 Clock Circuitry

■ Stratix IV GX FPGA Clock Inputs and Outputs

The DE4 development board contains three types of clock inputs which include 16 global clock inputs pins, external PLL clock inputs and transceiver reference clock inputs. The clock input sources of the Stratix IV GX FPGA originate from two on-board oscillators, a 50MHz and 100MHz, driven through the clock buffers as well as other interfaces including HSMC, GPIO expansion headers, and SMA connectors. The overall clock distribution of the DE4 is presented in [Figure 2–23](#). [Table 2–20](#) depicts the clock options available and their associated DIP switch settings.

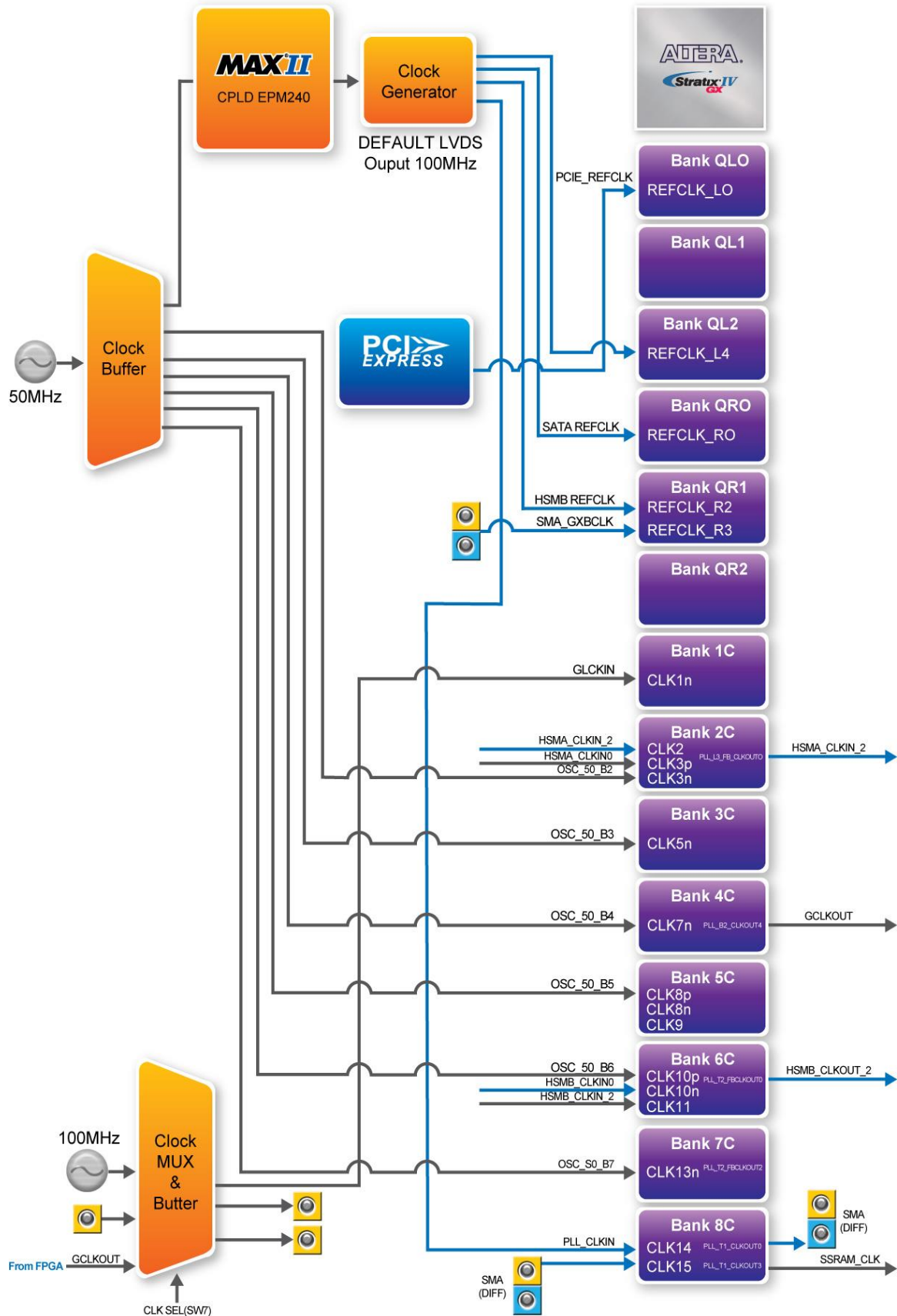
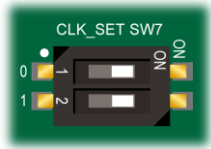
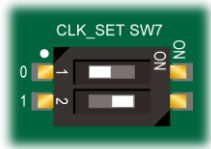
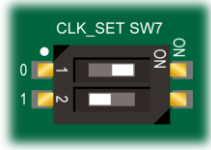
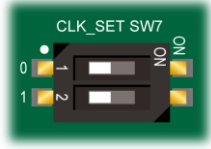

Figure 2–23 Clock connections of the DE4

Table 2–20 Clock Selections

SW7 Setting	Clock Selection	
00	100 MHz	
01	SMA_CLKIN	
10	GCLKOUT	
11	N/A	

The Stratix IV GX FPGA consists of 7 dedicated clock input pins and from those pins, 1 dedicated differential clock input listed in [Table 2–21](#). In addition, there are a total of 8 PLLs available for the Stratix IV GX device.

Table 2–21 Dedicated Clock Input Pins

Dedicated Clock Input Pins
HSMA_CLKIN_p1(differential)
HSMA_CLKIN_n1(differential)
HSMA_CLKIN0
OSC_50_B2
OSC_50_B5
OSC_50_B6
HSMB_CLKIN0

The dedicated clock input pins from the clock input multiplexer allow users to use any of these clocks as a source clock to drive the Stratix IV PLL circuit through the GCLK and RCLK networks. Alternatively, PLLs through the GCLK and RCLK networks or from dedicated connections on

adjacent top/bottom and left/right PLLs can also drive the PLL circuit. The clock outputs of Stratix IV GX FPGA are derived from various interfaces, notably the HSMC and the SMA connectors.

■ Stratix IV GX FPGA Transceiver Clock Inputs

The transceiver reference clock inputs for the serial protocols supported by the Stratix IV GX FPGA transceiver channels include the PCI Express (PIPE), SATA, and through the SMA connectors.

The DE4 uses three programmable low-jitter clock generators with default clock output of 100MHz and an I/O standard of LVDS that is non-configurable. The clock generators are programmed via Max II CPLD to generate the necessary clocks for the Stratix IV GX transceiver protocols and interfaces such as SATA and HSMC. The PCI Express (PIPE) transceiver reference clock is generated from the PCIe connector.

The clock frequency for the programmable clock generators can be specified by using the DE4 control panel, DE4 system builder, or the external clock generator demo provided. Note that signals PLL_CLKIN and SATA_REFCLK share the same clock generator which would lead to the same output frequency for both signals.

The associated pin assignments for clock buffer and SMA connectors to FPGA I/O pins are shown in [Table 2–22](#).

Table 2–22 Clock Inputs/Outputs Pin Assignments, Schematic Signal Names, and Functions

Board Reference	Schematic Signal Name	Description	I/O Standard	Stratix IV GX Pin Number
-	OSC_50_B2	Dedicated 50MHz clock input for bank 2C	2.5-V	PIN_AC35
-	OSC_50_B3	50MHz clock input for bank 3C	1.8-V	PIN_AV22
-	OSC_50_B4	50MHz clock input for bank 4C	1.8-V	PIN_AV19
-	OSC_50_B5	50MHz clock input for bank 5C	3.0-V	PIN_AC6
-	OSC_50_B6	50MHz clock input for bank 6C	2.5-V	PIN_AB6
-	OSC_50_B7	50MHz clock input for bank 7C	1.8-V	PIN_A19
-	GCLKIN	100MHz or SMA_CLKIN or GCLKOUT clock input	1.8-V	PIN_A21
-	GCLKOUT_FPGA	Single-ended clock output	1.8-V	PIN_AH19

-	PLL_CLKIN_p	Programmable 100MHz differential clock input	2.5-V or LVDS	PIN_B22
-	PLL_CLKIN_n	Programmable 100MHz differential clock input	2.5-V or LVDS	PIN_A22
J15	SMA_CLKIN_p	SMA differential clock input	2.5-V or LVDS	PIN_B23
J19	SMA_CLKIN_n	SMA differential clock input	2.5-V or LVDS	PIN_A23
J13	SMA_GXBCLK_p	SMA transceiver reference clock input	LVDS	PIN_W2
J17	SMA_GXBCLK_n	SMA transceiver reference clock input	LVDS	PIN_W1
-	SATA_REFCLK_p	SATA reference clock input	LVDS	PIN_AN2
-	SATA_REFCLK_n	SATA reference clock input	LVDS	PIN_AN1
-	HSMC_REFCLK_p	HSMC-A transceiver reference clock input	LVDS	PIN_J38
-	HSMC_REFCLK_n	HSMC-A transceiver reference clock input	LVDS	PIN_J39
-	HSMC_REFCLK_p	HSMC-B transceiver reference clock input	LVDS	PIN_AA2
-	HSMC_REFCLK_n	HSMC-B transceiver reference clock input	LVDS	PIN_AA1

2.11 PCI Express

The DE4 development board is designed to fit entirely into a PC motherboard with x8 or x16 PCI Express slot. Utilizing built-in transceivers on a Stratix IV GX device, it is able to provide a fully integrated PCI Express-compliant solution for multi-lane (x1, x4, and x8) applications. With the PCI Express hard IP block incorporated in the Stratix IV GX device, it will allow users to implement simple and fast protocol, as well as saving logic resources for logic application. **Figure 2–24** presents the pin connection established between the Stratix IV GX and PCI Express.

The PCI Express interface supports complete PCI Express Gen1 at 2.5Gbps/lane and Gen2 at 5.0Gbps/lane protocol stack solution compliant to PCI Express base specification 2.0 that includes PHY-MAC, Data Link, and transaction layer circuitry embedded in PCI Express hard IP blocks.

The power of the board can be sourced entirely from the PCI Express edge connector when installed into a PC motherboard. An optional PCIe external power source can be connected if larger power is required on the DE4. It is recommended that users connect the PCIe external power connector to the DE4 when either the HSMC or GPIO interface is occupied by a daughter card. The PCIE_REFCLK_P signal is a differential input that is driven from the PC motherboard on this

board through the PCIe edge connector. A DIP switch (SW9) is connected to the PCI Express to allow different configuration to enable an x1, x4, or x8 PCIe.

Table 2–23 summarizes the PCI Express pin assignments of the signal names relative to the Stratix IV GX FPGA.

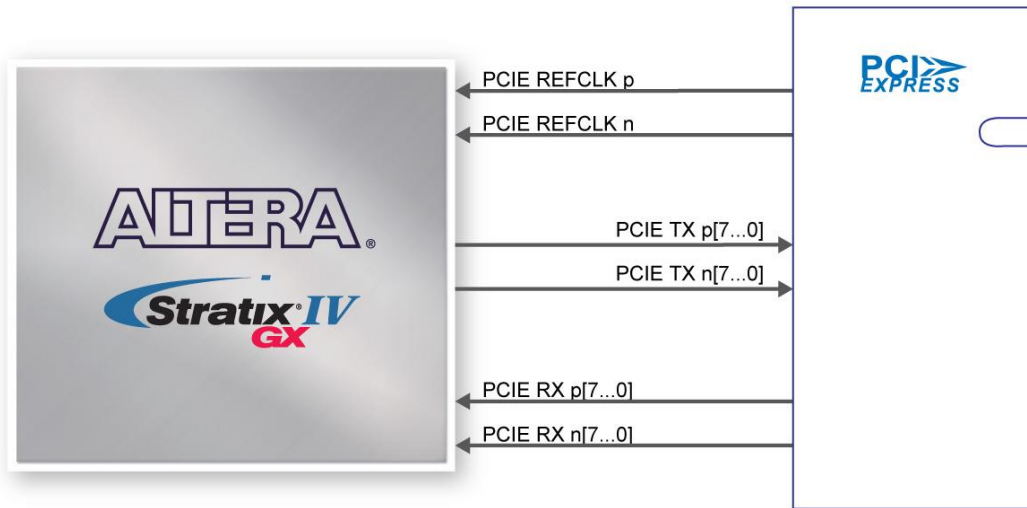

Figure 2–24 PCI Express pin connection

Table 2–23 PCI Express Pin Assignments, Schematic Signal Names, and Functions

<i>Schematic Signal Name</i>	<i>Description</i>	<i>I/O Standard</i>	<i>Stratix IV GX Pin Number</i>
PCIE_TX_p0_NET	Add-in card transmit bus	1.4-V PCML	PIN_AT36
PCIE_TX_n0_NET	Add-in card transmit bus	1.4-V PCML	PIN_AT37
PCIE_TX_p1_NET	Add-in card transmit bus	1.4-V PCML	PIN_AP36
PCIE_TX_n1_NET	Add-in card transmit bus	1.4-V PCML	PIN_AP37
PCIE_TX_p2_NET	Add-in card transmit bus	1.4-V PCML	PIN_AH36
PCIE_TX_n2_NET	Add-in card transmit bus	1.4-V PCML	PIN_AH37
PCIE_TX_p3_NET	Add-in card transmit bus	1.4-V PCML	PIN_AF36
PCIE_TX_n3_NET	Add-in card transmit bus	1.4-V PCML	PIN_AF37
PCIE_TX_p4_NET	Add-in card transmit bus	1.4-V PCML	PIN_AD36
PCIE_TX_n4_NET	Add-in card transmit bus	1.4-V PCML	PIN_AD37
PCIE_TX_p5_NET	Add-in card transmit bus	1.4-V PCML	PIN_AB36
PCIE_TX_n5_NET	Add-in card transmit bus	1.4-V PCML	PIN_AB37
PCIE_TX_p6_NET	Add-in card transmit bus	1.4-V PCML	PIN_T36
PCIE_TX_n6_NET	Add-in card transmit bus	1.4-V PCML	PIN_T37
PCIE_TX_p7_NET	Add-in card transmit bus	1.4-V PCML	PIN_P36

PCIE_TX_n7_NET	Add-in card transmit bus	1.4-V PCML	PIN_P37
PCIE_RX_p0	Add-in card receive bus	1.4-V PCML	PIN_AU38
PCIE_RX_n0	Add-in card receive bus	1.4-V PCML	PIN_AU39
PCIE_RX_p1	Add-in card receive bus	1.4-V PCML	PIN_AR38
PCIE_RX_n1	Add-in card receive bus	1.4-V PCML	PIN_AR39
PCIE_RX_p2	Add-in card receive bus	1.4-V PCML	PIN_AJ38
PCIE_RX_n2	Add-in card receive bus	1.4-V PCML	PIN_AJ39
PCIE_RX_p3	Add-in card receive bus	1.4-V PCML	PIN_AG38
PCIE_RX_n3	Add-in card receive bus	1.4-V PCML	PIN_AG39
PCIE_RX_p4	Add-in card receive bus	1.4-V PCML	PIN_AE38
PCIE_RX_n4	Add-in card receive bus	1.4-V PCML	PIN_AE39
PCIE_RX_p5	Add-in card receive bus	1.4-V PCML	PIN_AC38
PCIE_RX_n5	Add-in card receive bus	1.4-V PCML	PIN_AC39
PCIE_RX_p6	Add-in card receive bus	1.4-V PCML	PIN_U38
PCIE_RX_n6	Add-in card receive bus	1.4-V PCML	PIN_U39
PCIE_RX_p7	Add-in card receive bus	1.4-V PCML	PIN_R38
PCIE_RX_n7	Add-in card receive bus	1.4-V PCML	PIN_R39
PCIE_REFCLK_p	Motherboard reference clock	HCSL	PIN_AN38
PCIE_REFCLK_n	Motherboard reference clock	HCSL	PIN_AN39
PCIE_PREST_n	Reset	2.5-V	PIN_V30
PCIE_SMBCLK	SMB clock	2.5-V	PIN_R31
PCIE_SMBDAT	SMB data	2.5-V	PIN_W33
PCIE_WAKE_n	Wake signal	2.5-V	PIN_U35
PCIE_PRSENT1n	Hot plug detect	-	-
PCIE_PRSENT2n_x1	Hot plug detect x1 PCIe slot enabled using SW9 dip switch	-	-
PCIE_PRSENT2n_x4	Hot plug detect x4 PCIe slot enabled using SW9 dip switch	-	-
PCIE_PRSENT2n_x8	Hot plug detect x8 PCIe slot enabled using SW9 dip switch	-	-

■ Trigger Switch

The DE4 provides a 2-pin header (JP2) with one pin connected directly to the Stratix IV GX FPGA, while the other pin connected to GND. The 2-pin header is intended to be used as a trigger switch (not included in the DE4 kit package). It is placed in a location where the PCIe bracket is installed which conveniently allows users to install a trigger switch to the 2-pin header as the DE4 is connected to the PC through the PCIe slot shown in [Figure 2–25](#). Users can incorporate the trigger switch in their design as a reset or trigger function. [Table 2–24](#) shows the pin assignments of the 2-pin header.

Table 2–24 2-pin header Pin Assignments, Schematic Signal Names, and Functions

Schematic Signal Name	Description	I/O Standard	Stratix IV GX Pin Number
EXT_IO	General Purpose I/O	3.0-V	PIN_AC11

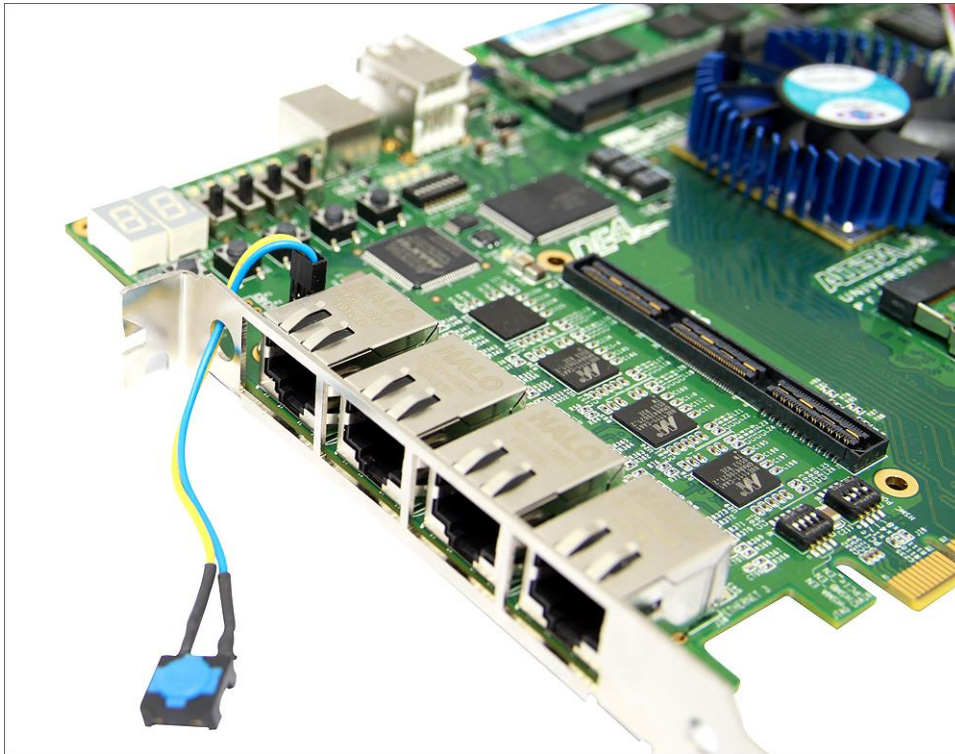

Figure 2–25 PCIe bracket setup with the trigger switch connected to 2-pin header (JP2)

2.12 Gigabit Ethernet (GigE)

The DE4 development board is equipped with four Marvell Integrated 10/100/1000 Gigabit Ethernet transceiver devices. The device is an auto-negotiating Ethernet PHY with a default SGMII MAC interface. The Marvell device is powered by 2.5V and 1.1V power rails and also requires a 25MHz reference clock driven from a dedicated 25MHz oscillator. The transmitter and receiver signals of the Marvell device are connected directly to the LVDS I/Os of the Stratix IV GX device with speeds at 1.2Gbps. The integrated Ethernet transceiver through internal magnetics to RJ45 can be used to drive copper lines with Ethernet traffic. **Figure 2–26** illustrates the overall structure and connection between the RJ45 ports and the 88E1111 devices, while **Table 2–25** lists the default settings for the four chips.

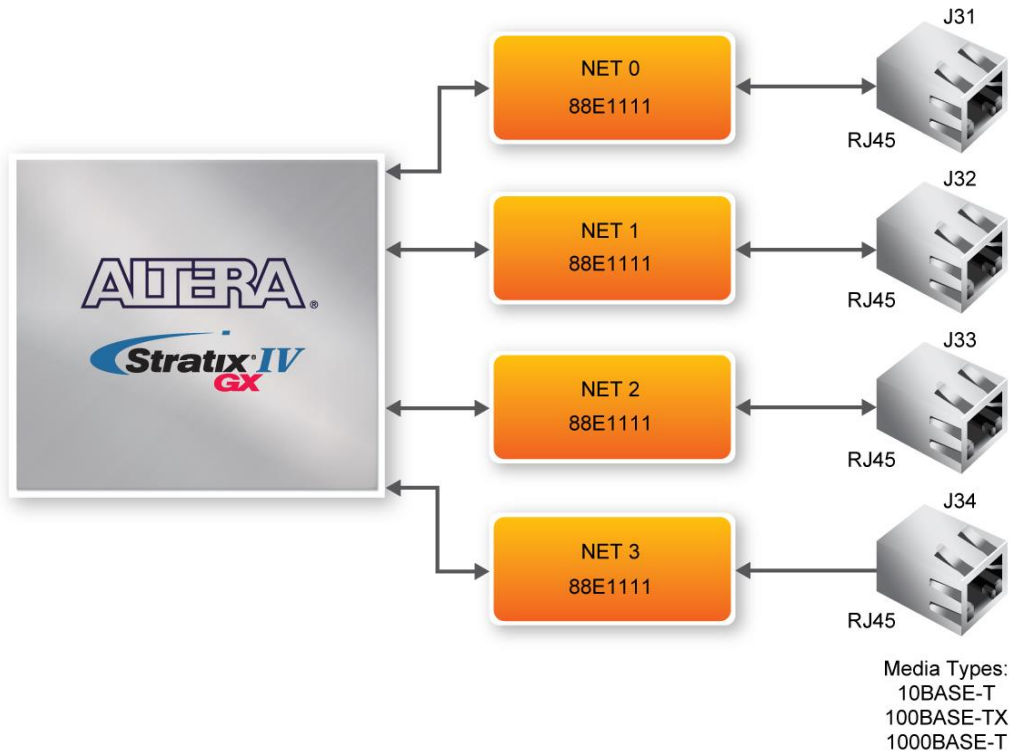

Figure 2–26 Overall connection of the Ethernet devices

Table 2–25 Default Configuration for Gigabit Ethernet

Configuration	Ethernet MAC port	Default Value
PHYADDR[4:0]	PHY Address in MDIO/MDC Mode	00000 for Enet0; 00001 for Enet1; 00010 for Enet2; 00011 for Enet3
ENA_PAUSE	Enable Pause	0-Default Register 4.11:10 to 00
ANEG[3:0]	Auto negotiation configuration for copper modes	1110-Auto-neg, advertise all capabilities, prefer master
ENA_XC	Enable Crossover	0-Disable
DIS_125	Disable 125MHz clock	1-Disable 125CLK
HWCFG[3:0]	Hardware Configuration Mode	0100 SGMII without clock with SGMII Auto-Neg to copper
DIS_FC	Disable fiber/copper interface	1-Disable
DIS_SLEEP	Energy detect	1-Disable energy detect
SEL_TWSI	Interface select	0-Select MDC/MDIO interface
INT_POL	Interrupt polarity	1-INTn signal is active LOW

75/50OHM	Termination resistance	0-50 ohm termination for fiber
----------	------------------------	--------------------------------

Table 2–26 lists the Ethernet signal names and their corresponding Stratix IV GX pin numbers.

Table 2–26 Ethernet PHY Pin Assignments, Schematic Signal Names, and Functions

<i>Schematic Signal Name</i>	<i>Description</i>	<i>I/O Standard</i>	<i>Stratix IV GX Pin Number</i>
Ethernet 0			
ETH_TX_p0	TX data	LVDS	PIN_T30
ETH_TX_n0	TX data	LVDS	PIN_T31
ETH_RX_p0	RX data	LVDS	PIN_U31
ETH_RX_n0	RX data	LVDS	PIN_V31
ETH_MDC0	Management bus control	2.5-V	PIN_R30
ETH_MDIO0	Management bus data	2.5-V	PIN_W32
ETH_INT_n0	Management bus interrupt	1.8-V	PIN_B20
ETH_RST_n	Device reset	2.5-V	PIN_V29
Ethernet 1			
ETH_TX_p1	TX data	LVDS	PIN_R32
ETH_TX_n1	TX data	LVDS	PIN_R33
ETH_RX_p1	RX data	LVDS	PIN_N33
ETH_RX_n1	RX data	LVDS	PIN_N34
ETH_MDC1	Management bus control	2.5-V	PIN_J6
ETH_MDIO1	Management bus data	2.5-V	PIN_J5
ETH_INT_n1	Management bus interrupt	2.5-V	PIN_AG30
ETH_RST_n	Device reset	2.5-V	PIN_V29
Ethernet 2			
ETH_TX_p2	TX data	LVDS	PIN_M32
ETH_TX_n2	TX data	LVDS	PIN_L32
ETH_RX_p2	RX data	LVDS	PIN_K34
ETH_RX_n2	RX data	LVDS	PIN_K35
ETH_MDC2	Management bus control	2.5-V	PIN_K6
ETH_MDIO2	Management bus data	2.5-V	PIN_K5
ETH_INT_n2	Management bus interrupt	2.5-V	PIN_AE30
ETH_RST_n	Device reset	2.5-V	PIN_V29
Ethernet 3			
ETH_TX_p3	TX data	LVDS	PIN_P31
ETH_TX_n3	TX data	LVDS	PIN_P32
ETH_RX_p3	RX data	LVDS	PIN_J34
ETH_RX_n3	RX data	LVDS	PIN_J35
ETH_MDC3	Management bus control	2.5-V	PIN_N7
ETH_MDIO3	Management bus data	2.5-V	PIN_N8
ETH_INT_n3	Management bus interrupt	2.5-V	PIN_AE31
ETH_RST_n	Device reset	2.5-V	PIN_V29

2.13 Serial ATA (SATA)

Four Serial ATA (SATA) ports available on the DE4 development board which are computer bus standard with the primary function of transferring data between the motherboard and mass storage devices (such as hard drives, optical drives, and solid-state disks). Supporting a storage interface is just one of many different applications an FPGA can be used in storage appliances. The Stratix IV GX device can bridge different protocols such as bridging simple bus I/Os like PCI Express (PCIe) to SATA or network interfaces such as Gigabit Ethernet (GbE) to SATA. The SATA interface supports SATA 3.0 standard with connection speed of 6 Gbps based on Stratix IV GX device with integrated transceivers compliant to SATA electrical standards.

The four Serial ATA (SATA) ports include two available ports for device and two available ports for host capable of implementing SATA solution with a design that consists of both host and target (device side) functions. **Figure 2–27** depicts the host and device design examples.



Figure 2–27 PC and storage device connection to the Stratix IV GX FPGA

The transmitter and receiver signals of the SATA ports are connected directly to the Stratix IV GX transceiver channels to provide SATA IO connectivity to both host and target devices. To verify the functionality of the SATA host/device ports, a connection can be established between the two ports by using a SATA cable as **Figure 2–28** depicts the associated signals connected. **Table 2–27** lists the SATA pin assignments, signal names and functions.

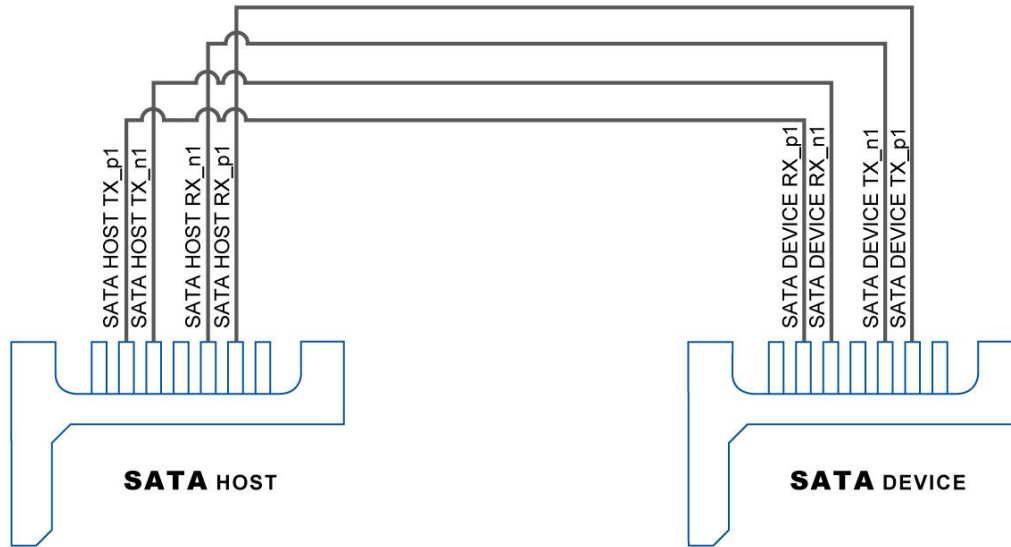

Figure 2–28 Pin connection between SATA connectors

Table 2–27 Serial ATA Pin Assignments, Schematic Signal Names, and Functions

Schematic Signal Name	Description	I/O Standard	Stratix IV GX Pin Number
Device			
SATA_DEVICE_RX_p0	Differential receive data input after DC blocking capacitor	1.4-V PCML	PIN_AU2
SATA_DEVICE_RX_n0	Differential receive data input after DC blocking capacitor	1.4-V PCML	PIN_AU1
SATA_DEVICE_TX_n0	Differential transmit data output before DC blocking capacitor	1.4-V PCML	PIN_AT3
SATA_DEVICE_TX_p0	Differential transmit data output before DC blocking capacitor	1.4-V PCML	PIN_AT4
SATA_DEVICE_RX_p1	Differential receive data input after DC blocking capacitor	1.4-V PCML	PIN_AJ2
SATA_DEVICE_RX_n1	Differential receive data input after DC blocking capacitor	1.4-V PCML	PIN_AJ1
SATA_DEVICE_TX_n1	Differential transmit data output before DC blocking capacitor	1.4-V PCML	PIN_AH3
SATA_DEVICE_TX_p1	Differential transmit data output before DC blocking capacitor	1.4-V PCML	PIN_AH4
Host			
SATA_HOST_TX_p0	Differential transmit data output before DC blocking capacitor	1.4-V PCML	PIN_AP4
SATA_HOST_TX_n0	Differential transmit data output	1.4-V PCML	PIN_AP3

	before DC blocking capacitor		
SATA_HOST_RX_n0	Differential receive data input after DC blocking capacitor	1.4-V PCML	PIN_AR1
SATA_HOST_RX_p0	Differential receive data input after DC blocking capacitor	1.4-V PCML	PIN_AR2
SATA_HOST_TX_p1	Differential transmit data output before DC blocking capacitor	1.4-V PCML	PIN_AF4
SATA_HOST_TX_n1	Differential transmit data output before DC blocking capacitor	1.4-V PCML	PIN_AF3
SATA_HOST_RX_n1	Differential receive data input after DC blocking capacitor	1.4-V PCML	PIN_AG1
SATA_HOST_RX_p1	Differential receive data input after DC blocking capacitor	1.4-V PCML	PIN_AG2

2.14 RS-232 Serial Port

The DE4 board uses the ADM3202 transceiver chip and a 9-pin D-SUB connector for RS-232 communication. For detailed information on how to use the transceiver, refer to the datasheet which is available on the manufacturer's website, or in the *Datasheet/RS232* folder on the **DE4 System CD-ROM**. **Table 2–28** lists the RS-232 pin assignments, signal names and functions.

Table 2–28 RS-232 Pin Assignments, Schematic Signal Names, and Functions

<i>Schematic Signal Name</i>	<i>Description</i>	<i>I/O Standard</i>	<i>Stratix IV GX Pin Number</i>
UART_TXD	Receiver Output	2.5-V	PIN_AN34
UART_CTS	Receiver Output	2.5-V	PIN_AN35
UART_RXD	Transmitter (Driver) Input	2.5-V	PIN_AH32
UART_RTS	Transmitter (Driver) Input	2.5-V	PIN_AH33

Note for **Table 2–28**:

*The RS-232 signals are level-shifted from 2.5V (FPGA) to 3.3V (RS-232).

2.15 FLASH Memory

The DE4 development board features a 64MB PC28F512P30BFA CFI-compliant NOR-type flash memory device which is part of the shared FMS Bus consisting of flash memory, SSRAM, and the Max II CPLD (EPM2210) System Controller. The single synchronous flash memory with 16-bit data bus supports 4-word, 8-word 16-word, and continuous-word burst mode provides non-volatile

storage that can be used for configuration as well as software storage. The memory interface can sustain output synchronous-burst read operations at 40-MHz with zero wait states. The device defaults to asynchronous page-mode read when power-up is initiated or returned from reset.

This device is also used to store configuration files for the Stratix IV GX FPGA where the MAX II CPLD (EPM2210) can access flash for FPP configuration of the FPGA using the PFL Megafunction.

Table 2–29 lists the flash pin assignments, signal names, and functions.

Table 2–29 Flash Memory Pin Assignments, Schematic Signal Names, and Functions

<i>Schematic Signal Name</i>	<i>Description</i>	<i>I/O Standard</i>	<i>Stratix IV GX Pin Number</i>
FSM_A1	Address bus	2.5-V	PIN_G22
FSM_A2	Address bus	2.5-V	PIN_G23
FSM_A3	Address bus	2.5-V	PIN_A25
FSM_A4	Address bus	2.5-V	PIN_H22
FSM_A5	Address bus	2.5-V	PIN_H23
FSM_A6	Address bus	2.5-V	PIN_J22
FSM_A7	Address bus	2.5-V	PIN_K22
FSM_A8	Address bus	2.5-V	PIN_M21
FSM_A9	Address bus	2.5-V	PIN_J23
FSM_A10	Address bus	2.5-V	PIN_F34
FSM_A11	Address bus	2.5-V	PIN_G35
FSM_A12	Address bus	2.5-V	PIN_E34
FSM_A13	Address bus	2.5-V	PIN_J32
FSM_A14	Address bus	2.5-V	PIN_F35
FSM_A15	Address bus	2.5-V	PIN_C24
FSM_A16	Address bus	2.5-V	PIN_A24
FSM_A17	Address bus	2.5-V	PIN_D23
FSM_A18	Address bus	2.5-V	PIN_D24
FSM_A19	Address bus	2.5-V	PIN_T27
FSM_A20	Address bus	2.5-V	PIN_T28
FSM_A21	Address bus	2.5-V	PIN_D22
FSM_A22	Address bus	2.5-V	PIN_E23
FSM_A23	Address bus	2.5-V	PIN_N20
FSM_A24	Address bus	2.5-V	PIN_P20
FSM_A25	Address bus	2.5-V	PIN_C22
FSM_D0	Data bus	2.5-V	PIN_K29
FSM_D1	Data bus	2.5-V	PIN_J30
FSM_D2	Data bus	2.5-V	PIN_K30
FSM_D3	Data bus	2.5-V	PIN_L29
FSM_D4	Data bus	2.5-V	PIN_K31
FSM_D5	Data bus	2.5-V	PIN_E32

FSM_D6	Data bus	2.5-V	PIN_F32
FSM_D7	Data bus	2.5-V	PIN_H32
FSM_D8	Data bus	2.5-V	PIN_B32
FSM_D9	Data bus	2.5-V	PIN_C32
FSM_D10	Data bus	2.5-V	PIN_C35
FSM_D11	Data bus	2.5-V	PIN_D35
FSM_D12	Data bus	2.5-V	PIN_M22
FSM_D13	Data bus	2.5-V	PIN_M28
FSM_D14	Data bus	2.5-V	PIN_C31
FSM_D15	Data bus	2.5-V	PIN_D31
FLASH_CLK	Clock	2.5-V	PIN_E22
FLASH_RESET_n	Reset	2.5-V	PIN_D21
FLASH_CE_n	Chip enable	2.5-V	PIN_F23
FLASH_OE_n	Output enable	2.5-V	PIN_N21
FLASH_WE_n	Write enable	2.5-V	PIN_R20
FLASH_ADV_n	Address valid	2.5-V	PIN_F21
FLASH_RDY_BSY_n	Ready	2.5-V	PIN_G21
FLASH_WP_n	Write protect	-	-

2.16 SSRAM Memory

The IS61NVP102418 Synchronous Static Random Access Memory (SSRAM) device featured on the DE4 development board is part of the shared FMS Bus, which connects to flash memory, SSRAM, and the MAX II CPLD (E2PROM) System Controller. This device is a Zero-bus turnaround (ZBT) 2MB SRAM device with a 16-bit data bus providing no bus latency synchronous-burst SRAM with a simplified interface that fully uses available bandwidth by removing the turnaround cycles between read and write operations.

Table 2–30 lists the SSRAM pin assignments, signal names relative to the Stratix IV GX device in terms of I/O setting.

Table 2–30 SSRAM Memory Pin Assignments, Schematic Signal Names, and Functions

<i>Schematic Signal Name</i>	<i>Description</i>	<i>I/O Standard</i>	<i>Stratix IV GX Pin Number</i>
FSM_A1	Address bus	2.5-V	PIN_G22
FSM_A2	Address bus	2.5-V	PIN_G23
FSM_A3	Address bus	2.5-V	PIN_A25

FSM_A4	Address bus	2.5-V	PIN_H22
FSM_A5	Address bus	2.5-V	PIN_H23
FSM_A6	Address bus	2.5-V	PIN_J22
FSM_A7	Address bus	2.5-V	PIN_K22
FSM_A8	Address bus	2.5-V	PIN_M21
FSM_A9	Address bus	2.5-V	PIN_J23
FSM_A10	Address bus	2.5-V	PIN_F34
FSM_A11	Address bus	2.5-V	PIN_G35
FSM_A12	Address bus	2.5-V	PIN_E34
FSM_A13	Address bus	2.5-V	PIN_J32
FSM_A14	Address bus	2.5-V	PIN_F35
FSM_A15	Address bus	2.5-V	PIN_C24
FSM_A16	Address bus	2.5-V	PIN_A24
FSM_A17	Address bus	2.5-V	PIN_D23
FSM_A18	Address bus	2.5-V	PIN_D24
FSM_A19	Address bus	2.5-V	PIN_T27
FSM_A20	Address bus	2.5-V	PIN_T28
FSM_D0	Data bus	2.5-V	PIN_K29
FSM_D1	Data bus	2.5-V	PIN_J30
FSM_D2	Data bus	2.5-V	PIN_K30
FSM_D3	Data bus	2.5-V	PIN_L29
FSM_D4	Data bus	2.5-V	PIN_K31
FSM_D5	Data bus	2.5-V	PIN_E32
FSM_D6	Data bus	2.5-V	PIN_F32
FSM_D7	Data bus	2.5-V	PIN_H32
FSM_D8	Data bus	2.5-V	PIN_B32
FSM_D9	Data bus	2.5-V	PIN_C32
FSM_D10	Data bus	2.5-V	PIN_C35
FSM_D11	Data bus	2.5-V	PIN_D35
FSM_D12	Data bus	2.5-V	PIN_M22
FSM_D13	Data bus	2.5-V	PIN_M28
FSM_D14	Data bus	2.5-V	PIN_C31
FSM_D15	Data bus	2.5-V	PIN_D31
SSRAM_CLK	Clock	2.5-V	PIN_M31
SSRAM_BWA_n	Synchronous Byte lane A Write Input	2.5-V	PIN_R27
SSRAM_BWB_n	Synchronous Byte lane B Write Input	2.5-V	PIN_N31
SSRAM_OE_n	Output enable	2.5-V	PIN_H34
SSRAM_WE_n	Write enable	2.5-V	PIN_L31
SSRAM_CKE_n	Clock enable	2.5-V	PIN_N28
SSRAM_CE_n	Synchronous Chip enable	2.5-V	PIN_R28
SSRAM_ADV	Address valid	2.5-V	PIN_H35
SSRAM_MODE	Mode	-	-
SSRAM_CE2	Synchronous Chip enable	-	-

SSRAM_CE2_n	Synchronous Chip enable	-	-
SSRAM_ZZ	Sleep	-	-

2.17 I2C Serial EEPROM

A 24LC02B Microchip 2kbit Electrically Erasable PROM (EEPROM) is equipped on the DE4 which is configured through a 2-wire serial interface. The device is organized as one block of 256 x 8-bit memory. The detailed pin description between the Stratix IV GX FPGA and EEPROM is shown below in [Table 2–31](#).

Table 2–31 EEPROM Pin Assignments, Schematic Signal Names, and Functions

<i>Schematic Signal Name</i>	<i>Description</i>	<i>I/O Standard</i>	<i>Stratix IV GX Pin Number</i>
EEP_SCL	Serial Clock	2.5-V	PIN_G33
EEP_SDA	Serial Address/Data I/O	2.5-V	PIN_F33

2.18 Temperature Sensor

The DE4 is equipped with a temperature sensor MAX1619, which provides temperature sensing and over-temperature alert. These functions are accomplished by connecting the temperature sensor to the internal temperature sensing diode of the Stratix IV GX device. The temperature status and alarm threshold registers of the temperature sensor can be programmed by a two-wire SMBus, which is connected to the Stratix IV GX FPGA. In addition, the 7-bit POR slave address for this sensor is set to ‘0011000b’.

An optional 3-pin +12V fan located on J10 of the DE4 board is intended to reduce the temperature of the FPGA. When the temperature of the FPGA device is over the threshold value set by the users, the fan will turn on automatically. The pin assignments for the associated interface are listed in [Table 2–32](#).

Table 2–32 Temperature Sensor Pin Assignments, Schematic Signal Names, and Functions

<i>Schematic Signal Name</i>	<i>Description</i>	<i>I/O Standard</i>	<i>Stratix IV GX Pin Number</i>
TEMPDIODEp	Positive pin of temperature diode in	2.5-V	PIN_A9

	Stratix IV		
TEMPDIODEn	Negative pin of temperature diode in Stratix IV	2.5-V	PIN_E11
TEMP_SMCLK	SMBus clock	1.8-V	PIN_AN18
TEMP_SMDAT	SMBus data	1.8-V	PIN_AP18
TEMP_INT_n	SMBus alert (interrupt)	1.8-V	PIN_AP19
FAN_CTRL	Fan control	1.8-V	PIN_AP20

2.19 Power

The DE4 Development Board has two selective power sources to choose from which include the DC power input and the PCIe edge connector. When the DE4 is connected to the PCIe slot, an optional 6-pin PCIe external power connector can be connected to a PC power supply in case additional power is required on the DE4. It is recommended that users connect the PCIe external power connector to the DE4 when either the HSMC or GPIO interface is occupied by a daughter card. The DC voltage is stepped down to various power rails used by the components on the board and installed into the HSMC connectors.

■ Power Switch

The slide switch (SW5) is the board power switch for the DC power input. When the slide switch is in the ON position, the board is power on. Alternatively when the switch is in the OFF position, the board is power off.

■ Power Measurement

There are 12 power supply rails which have on-board voltage and current sense capabilities. These 8-channel differential 24-bit ADC devices and rails are split from the primary supply plane by a low-value sense resistor for the ADC to measure voltage and current. A SPI bus connects these ADC devices through level shifters to the Stratix IV GX FPGA. **Figure 2–29** shows the block diagram for the power measurement circuitry.

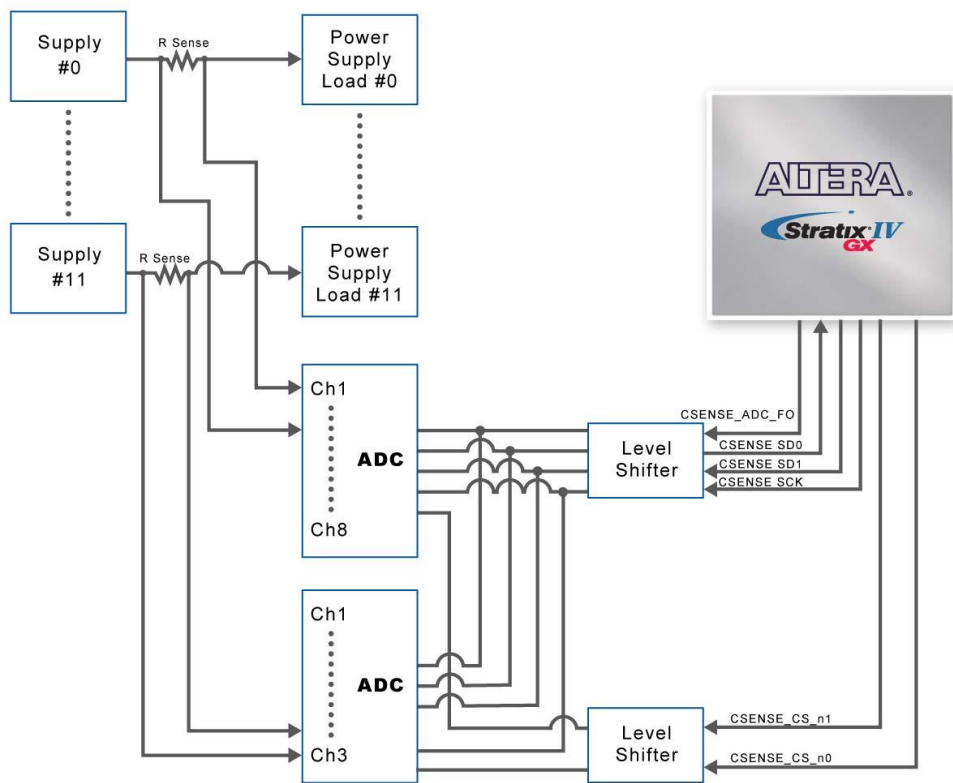

Figure 2-29 Power measurement circuit

Table 2-33 lists the targeted rails. The schematic signal name specifies the name of the rail being measured and the device pin denotes the devices attached to the rail.

Table 2-33 Power Rail Measurements

Switch	Schematic Signal Name	Voltage	Description
0	GPIO_VCCIOPD	3.0-V	Bank 5A & 5C IO Pre-Driver
1	HSMA_VCCIO	2.5-V	Bank 2A & 2C IO power (HSMC port A)
2	HSMB_VCCIO	2.5-V	Bank 6A & 6C IO power (HSMC port B)
3	VCC1P8	1.8-V	Bank 3A, 3B, 3C 4A, 4B, 4C IO power
4	VCC1P8	1.8-V	Bank 7A, 7B, 7C, 8A, 8B, 8C IO power
5	VCC0P9	0.9-V	FPGA core and periphery power
6	VCCHIP	0.9-V	PCI Express hard IP block
7	VCCA_PLL	2.5-V	PLL analog power
8	VCCD_PLL	0.9-V	PLL digital power
9	VCCL_GXB	1.1-V	Transceiver clock power
10	VCCH_GXB	1.4-V	Transmitter clock power

11	VCC3P3_HSMC	3.3-V	HSMC power (HSMC ports A and B)
----	-------------	-------	---------------------------------

Chapter 3

Control Panel

The DE4 board comes with a PC-based Control Panel that allows users to access various components onboard. The host computer communicates with the board via USB port. The tool can be used to verify the functionality of components.

This chapter presents some basic functions of the Control Panel, illustrates its structure in block diagram form, and finally describes its capabilities.

3.1 Control Panel Setup

The Control Panel software utility is located in the directory “/Tools/DE4_ControlPanel” in the **DE4 System CD**. To execute the program, simply copy the whole folder to your host computer and launch the control panel by double clicking the **DE4_ControlPanel.exe**.

Note. Please make sure Quartus II and USB-Blaster Driver are installed before launching DE4 Control Panel. In addition, before the DE4 control panel is launched it is imperative the fan is installed on the Stratix IV GX device, to prevent excessive high temperature on the FPGA.

To activate the Control Panel, perform the following steps:

- Make sure Quartus II is installed successfully on your PC.
- Connect the supplied USB cable to the USB Blaster port and the supplied power cord to J4. Turn the power switch ON.
- Verify the connection on the USB blaster is available and not occupied or used between Quartus and DE4.
- Start the executable DE4_ControlPanel.exe on the host computer. **Figure 3–1** will appear and

the Control Panel starts to auto-detect the FPGA and download the .sof files.

- After the configuration file is programmed to the DE4 board, the FPGA device information will be displayed on the window.

Note the Control Panel will occupy the USB port, users will not be able to download any configuration file into the FPGA before you exit the Control Panel program.

The Control Panel is now ready, as shown in **Figure 3–2**



Figure 3–1 Download .sof files to the DE4 board



Figure 3–2 DE4 Control Panel is ready

If the connection between DE4 board and USB-Blaster is not established, or the DE4 board is not powered on before running the **DE4_ControlPanel.exe**, the Control Panel will fail to detect the FPGA and a warning message window will pop up as shown in **Figure 3–3**.



Figure 3–3 The DE4 Control Panel fails to download .sof file

The concept of the DE4 Control Panel is illustrated in [Figure 3–4](#). The “Control Codes” which performs the control functions is implemented in the FPGA board. It communicates with the Control Panel window, which is active on the host computer, via the USB Blaster link. The graphical users interface is used to issue commands to the control codes. It handles all requests and performs data transfer between the computer and the DE4 board.

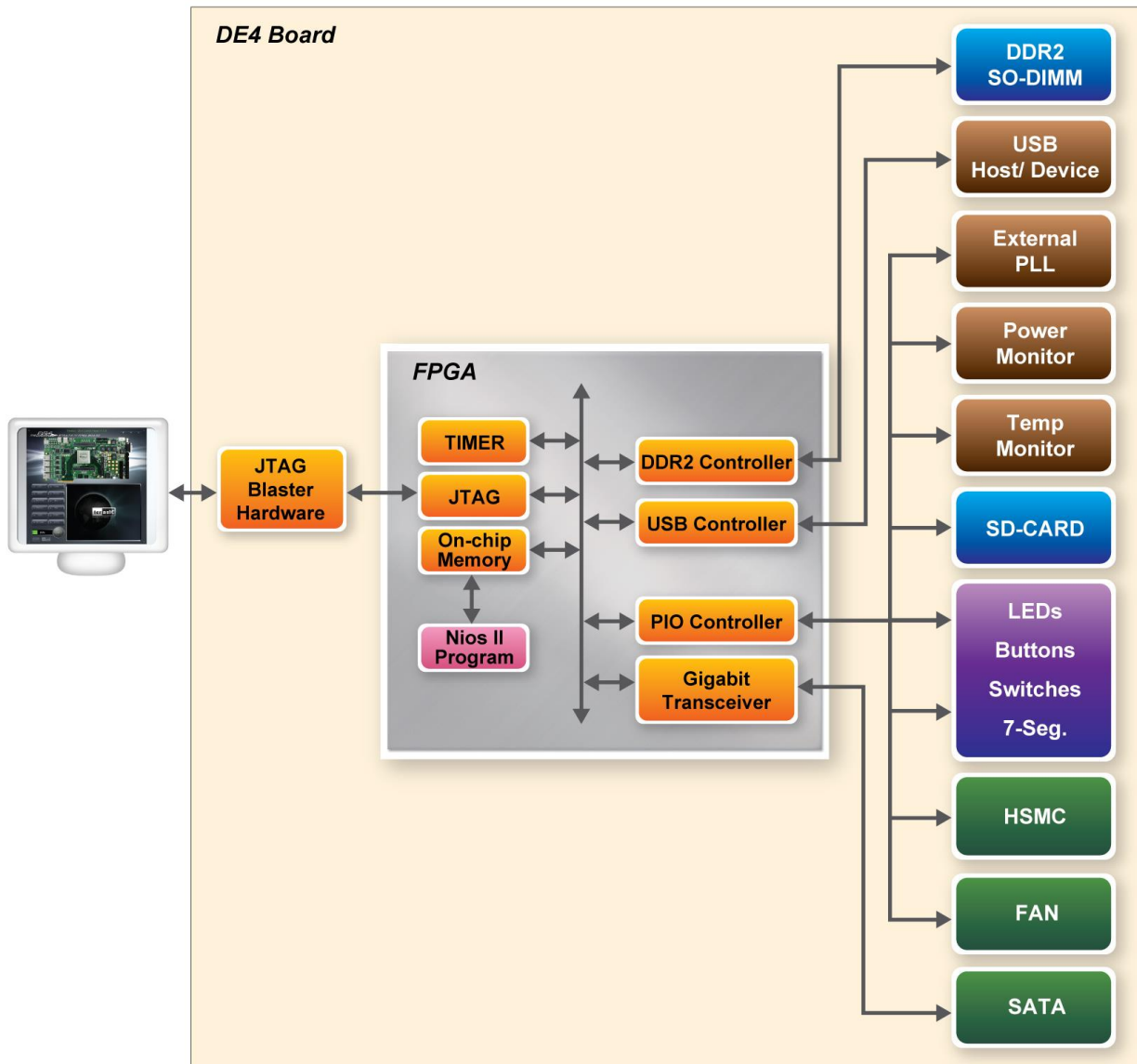

Figure 3–4 The DE4 Control Panel concept

The DE4 Control Panel can be used to illuminate the LEDs, change the values displayed on 7-segment displays, monitoring buttons/switches status, read/write from various memory types, in addition to testing various components of the DE4 board.

3.2 Controlling the LEDs and 7-Segment Displays

One of the functions of the Control Panel is to set up the status of the LEDs and 7-segment displays. The tab-window shown in Figure 3–5 indicates where you can directly turn all the LEDs on or off

individually by selecting them and clicking “Light All” or “Unlight All”.



Figure 3–5 Controlling LEDs

Figure 3–6 shows the interface of the 7-SEG and how to select desired patterns. The status of the 7-SEG patterns will be updated immediately.



Figure 3–6 Controlling 7-SEG display

3.3 SWITCH/BUTTON

Choose the **Button** tab as shown in **Figure 3–7**. This function is designed to monitor status of switches and buttons from a graphic interface in real-time. It can be used to verify the functionality of switches and buttons.



Figure 3–7 Monitoring Switches and Buttons

3.4 Memory Controller

The Control Panel can be used to write/read data to/from the DDR2 SO-DIMM/Flash/SSRAM/EEPROM memory on the DE4 board. Note, only the read function is supported on the flash memory of the DE4 Control Panel. We will describe how the DDR2 SO-DIMM is accessed. Click on the Memory tab to reach the tab-window shown in [Figure 3–8](#).

A 16-bit value can be written into the DDR2 SO-DIMM memory by three steps, namely specifying the address of the desired location, entering the hexadecimal data to be written, and pressing the **Write** button. Contents of the location can be read by pressing the **Read** button. [Figure 3–9](#) depicts the result of writing the hexadecimal value 7EFF to location 0x100, followed by reading the same location.

The Sequential Write function of the Control Panel is used to write the contents of a file to the serial configuration device, as described below:

- Specify the starting address in the Address box.
- Specify the number of bytes to be written in the Length box. If the entire file is to be loaded, a check mark can be placed in the File Length box instead of giving the number of bytes.
- To initiate the writing of data, click on the Write a File to Memory button.
- When the Control Panel responds with the standard Windows dialog box asking for the source file, specify the desired file in the usual manner.

The Sequential Read function is used to read the contents of the serial configuration device and place them into a file as follows:

- Specify the starting address in the Address box.
- Specify the number of bytes to be copied into a file in the Length box. If the entire contents of the serial configuration device are to be copied, then place a check mark in the Entire Memory box.
- Press Load Memory Content to a File button.
- When the Control Panel responds with the standard Windows dialog box ask for the destination file, users can specify the desired file in the usual manner.

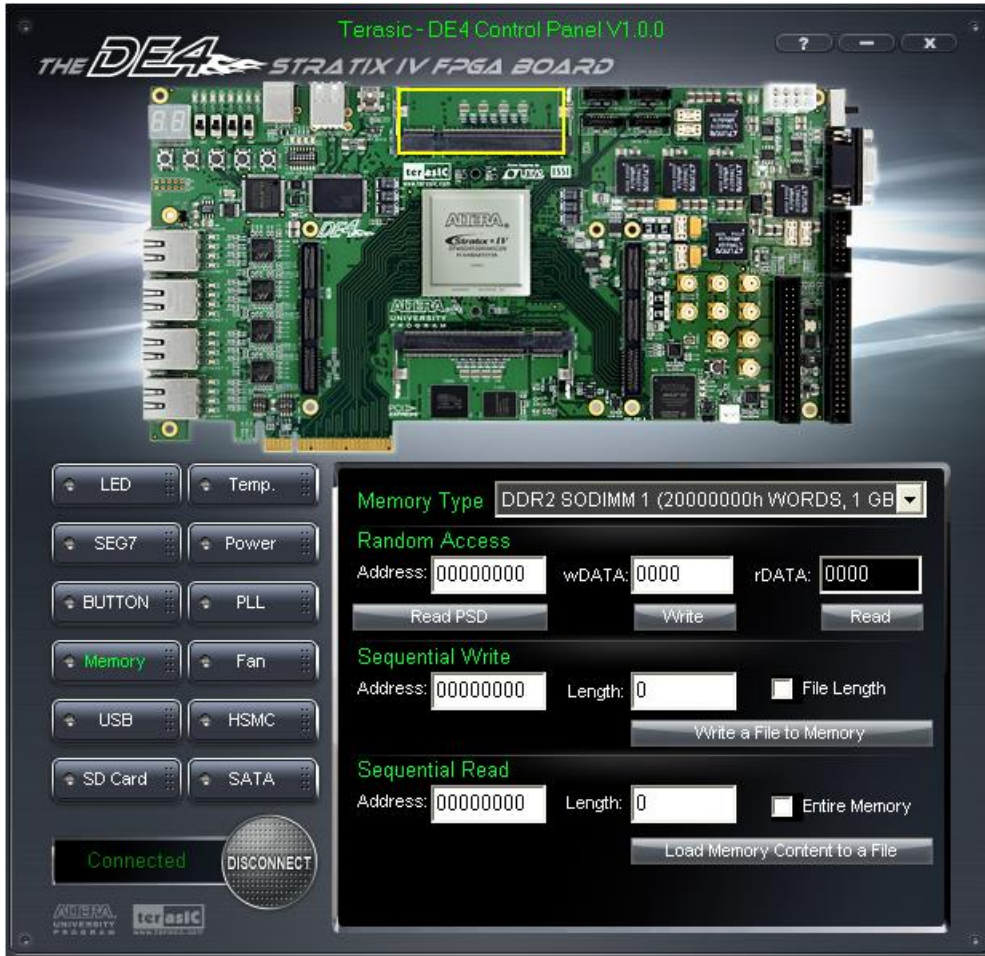

Figure 3–8 Access DDR2 SO-DIMM memory

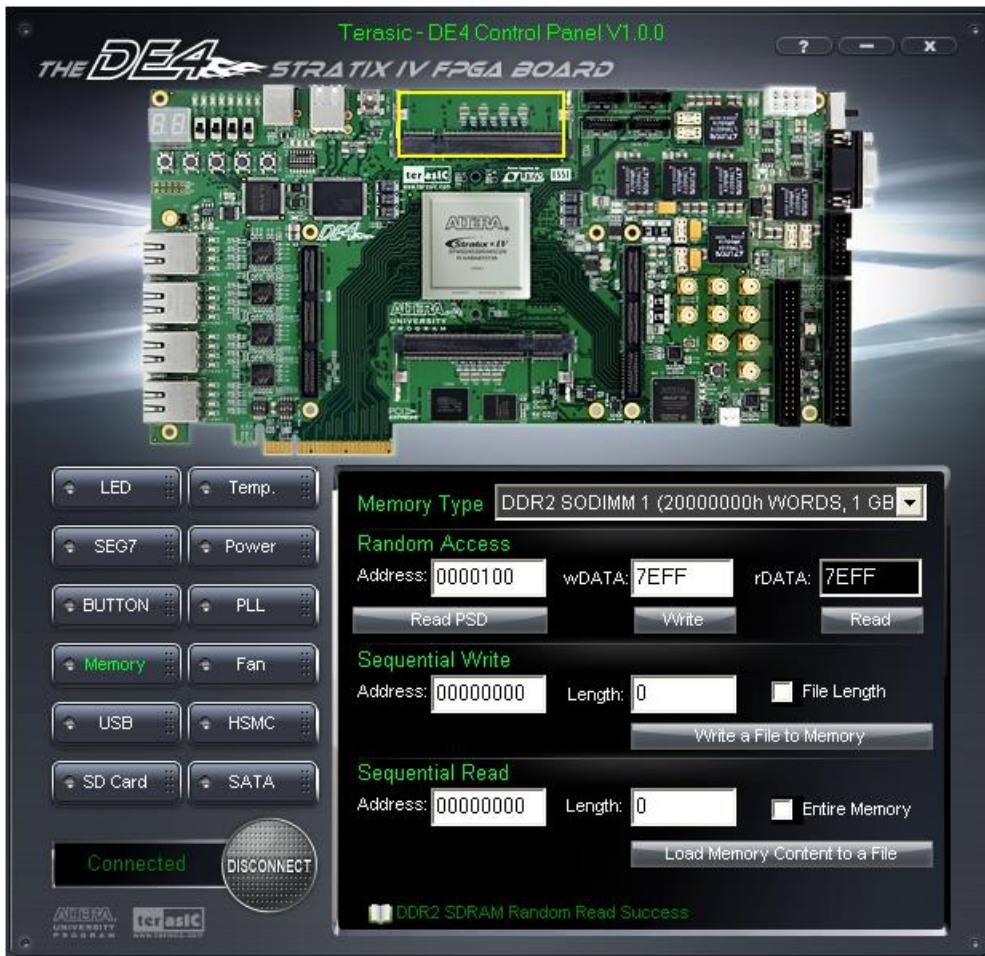

Figure 3–9 Writing the hexadecimal value 7EFF to location 0x100

3.5 USB2.0 OTG

Choose the **USB** tab to reach the window in **Figure 3–10**. This function is designed to monitor the status of USB Host Hub in real-time.

Plug a USB device to any USB port of FPGA board, and both the device type and speed will be displayed on the control window. **Figure 3–10** shows a USB storage device plugged into port 3.



Figure 3–10 Monitoring status of USB ports

3.6 SD CARD

Choose the **SD-CARD** tab to the window shown in [Figure 3–11](#). This function is designed to read the identification and specification of SD Card. 4-bit SD-MODE is used to access the SD Card. This function can be used to verify the functionality of SD-CARD interface.

To gather the information, simply insert a SD Card to the FPGA board and press the **Read** button. The SD-CARD identification and specification will be displayed on the control window



Figure 3–11 Reading the SD Card Identification and Specification

3.7 Temperature Monitor

Choose the **Temperature** tab to reach the window shown in **Figure 3–12**. This function is designed to control temperature sensor through Control Panel. The temperatures of Stratix IV GX and DE4 board are shown on the right-hand side of the Control Panel.

When the temperature of Stratix IV GX exceeds the maximum setting of ‘Over Temperature’ or ‘Alert’, a warning message will be shown on the Control Panel. Click “Read” button to get current settings for ‘Over temperature’ and ‘Alert’. Users can enter the maximum and minimum temperatures for ‘Over temperature’ or ‘Alert’ as required. Click the Write button to update the values entered.



Figure 3–12 Accessing the Temperature Sensor through Control Panel

3.8 Power

The Power function is designed to monitor the power consumption in real-time of various blocks on the DE4 board. Using the 12 power supply rails on the DE4 we are able to sense the on-board voltage and current for transceiver power, Stratix IV GX power, and the I/O power. Choose the Power tab to reach the window shown in [Figure 3–13](#) which depicts all associated power banks of the DE4 board.

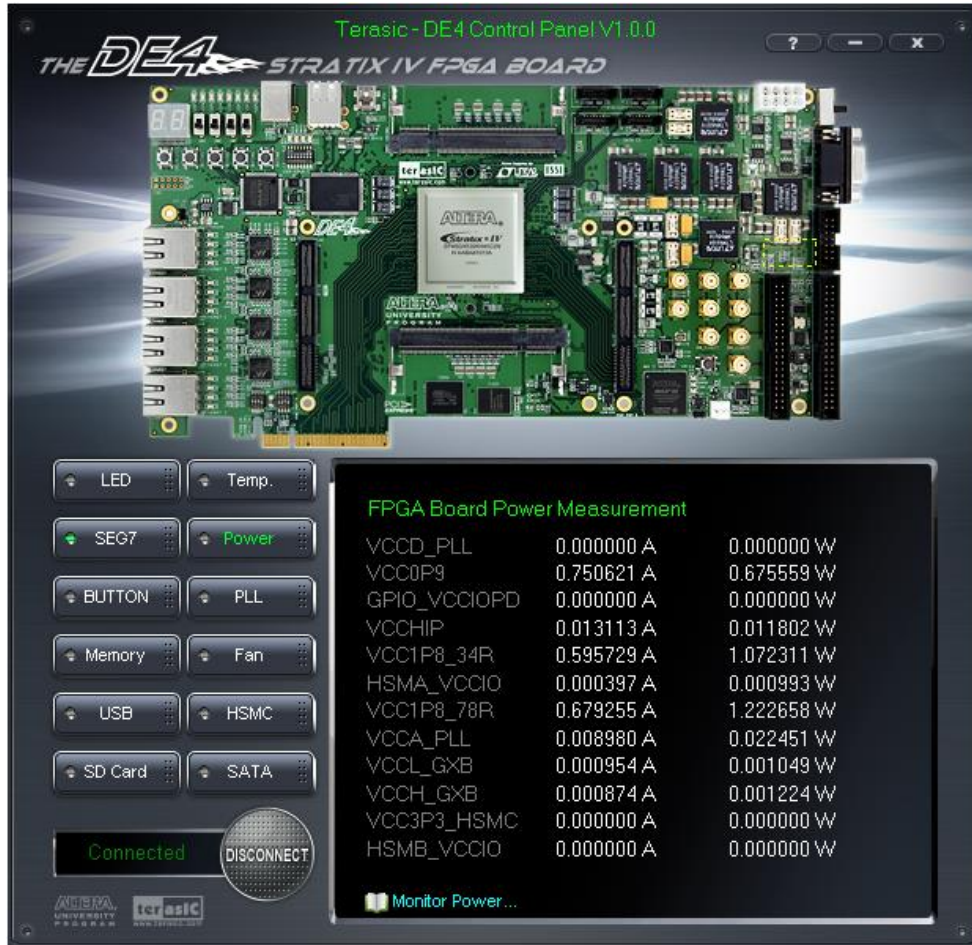

Figure 3–13 Power measurement for the associated power banks of the DE4

3.9 PLL

The PLL function is designed to configure the external programmable PLL on the DE4. There are 3 programmable clocks for the DE4 board that generates reference clocks for the following signals HSMA_REFCLK, HSMB_REFCLK, and PLL_CLKIN/SATA_REFCLK. The clock frequency can be adjusted to 62.5, 75, 100, 125, 150, 156.25, 187.5, 200, 250, 312.5, and 625MHz. Choose the ‘PLL’ tab to reach the window shown in [Figure 3–14](#). To set the desire clock frequency for the associated clock signal, click on ‘Set’.



Figure 3–14 Programmable External PLL configured through Control Panel

3.10 SATA

Choose the **SATA** tab to reach the window shown in **Figure 3–15**. This function is designed to verify the functionality of the transceiver signals found on the SATA interface using a loopback approach. Before running the Loopback verification SATA test, follow the ‘Loopback Installation’ and click on ‘Verify’.



Figure 3–15 SATA loopback verification test performed through the Control Panel

3.11 HSMC

Choose the **HSMC** tab to reach the window shown in **Figure 3–16**. This function is designed to verify the functionality of signals found on the HSMC connectors of ports A and B using a loopback approach. Before running the loopback verification HSMC test, select the desire HSMC connector to be tested on. Follow the instruction noted under Loopback Installation section and click on ‘Verify’. Please note to turn off the DE4 board before the HSMC loopback adapter is installed to prevent any damage to the DE4 board. Note the Control Panel HSMC loopback test does not tests the transceiver signals on the HSMC interface. For HSMC transceiver loopback test, please refer to the demonstration section.



Figure 3–16 HSMC loopback verification test performed under Control Panel

3.12 Fan

Choose the **Fan** tab to reach the window shown in **Figure 3–17**. This function is designed to verify the functionality of the fan components and signals. Please make sure the Fan is installed on the DE4 before running this function.

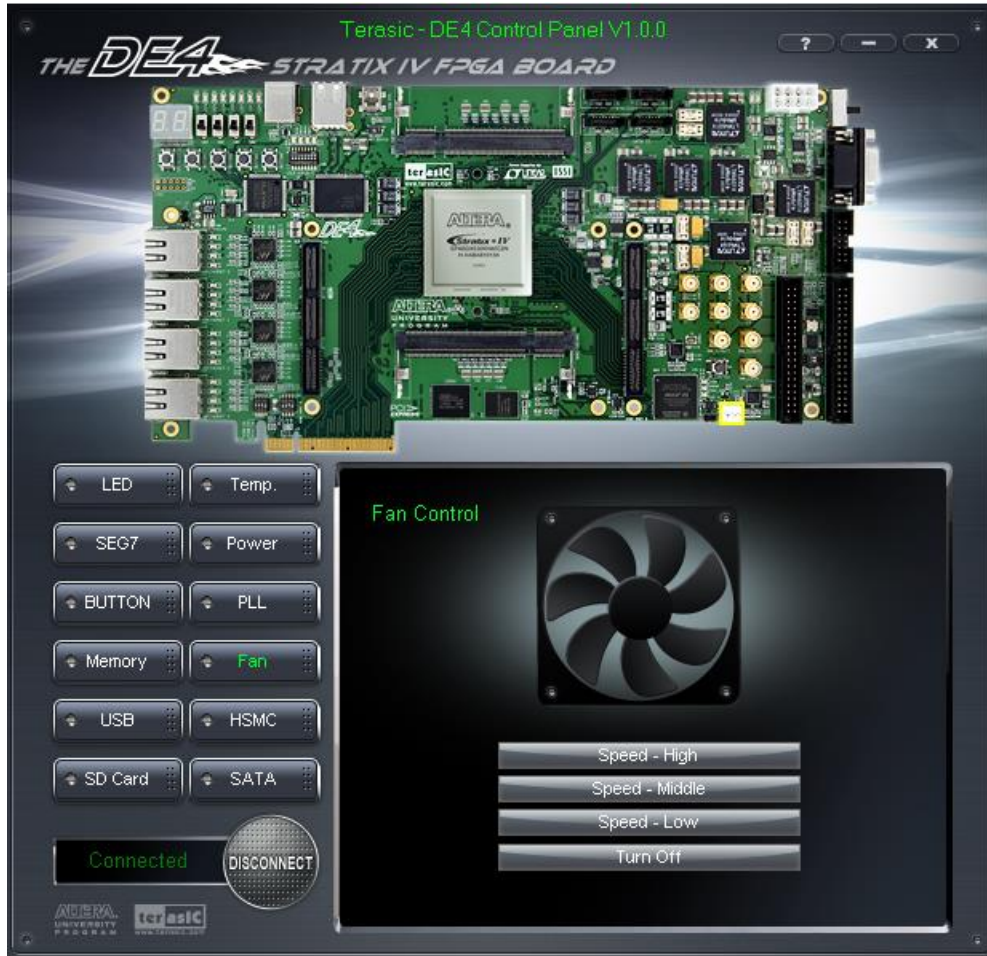

Figure 3–17 Fan Control of the DE4

Chapter 4

DE4 System Builder

This chapter describes how users can create a custom design project on the DE4 board by using DE4 Software Tools – DE4 System Builder.

4.1 Introduction

The DE4 System Builder is a Windows based software utility, designed to assist users to create a Quartus II project for the DE4 board within minutes. The generated Quartus II project files include:

- Quartus II Project File (.qpf)
- Quartus II Setting File (.qsf)
- Top-Level Design File (.v)
- External PLL Controller (.v)
- Synopsis Design Constraints file (.sdc)
- Pin Assignment Document (.htm)

The DE4 System Builder not only can generate the files above, but can also provide error-checking rules to handle situation that are prone to errors. The common mistakes that users encounter are the following:

- Board damaged for wrong pin/bank voltage assignment.
- Board malfunction caused by wrong device connections or missing pin counts for connected ends.
- Performance dropped because of improper pin assignments

4.2 General Design Flow

This section will introduce the general design flow to build a project for the DE4 board via the DE4 System Builder. The general design flow is illustrated in the [Figure 4-1](#).

Users should launch DE4 System Builder and create a new project according to their design requirements. When users complete the settings, the DE4 System Builder will generate two major files which include top-level design file (.v) and the Quartus II setting file (.qsf).

The top-level design file contains top-level verilog wrapper for users to add their own design/logic. The Quartus II setting file contains information such as FPGA device type, top-level pin assignment, and I/O standard for each user-defined I/O pin.

Finally, Quartus II programmer must be used to download SOF file to DE4 board using JTAG interface.

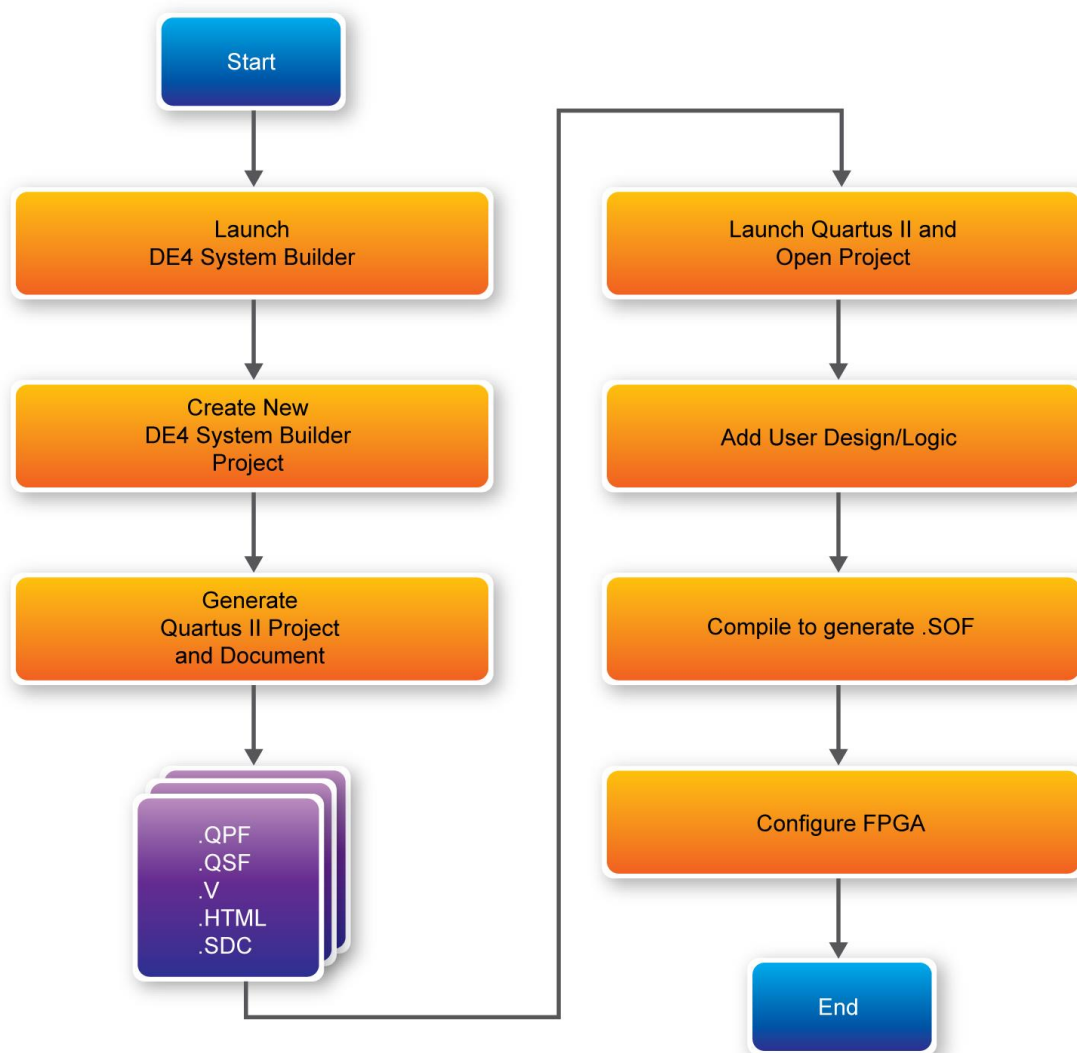

Figure 4–1 The general design flow of building a design

4.3 Using DE4 System Builder

This section provides the detail procedures on how the DE4 System Builder is used.

■ Install and launch the DE4 System Builder

The DE4 System Builder is located in the directory: "**Tools\DE4_SystemBuilder**" in the DE4 System CD. Users can copy the whole folder to a host computer without installing the utility. Before using the DE4 System Builder, execute the **DE4_SystemBuilder.exe** on the host computer

as appears in **Figure 4–2**.



Figure 4–2 The DE4 System Builder window

■ Select Board Type and Input Project Name

Select the target board type and input project name as show in **Figure 4–3**.

- **Board Type:** Select the appropriate FPGA device according to the DE4 board which includes the EP4SGX230 and EP4SGX530 devices.
- **Project Name:** Specify the project name as it is automatically assigned to the name of the top-level design entity.

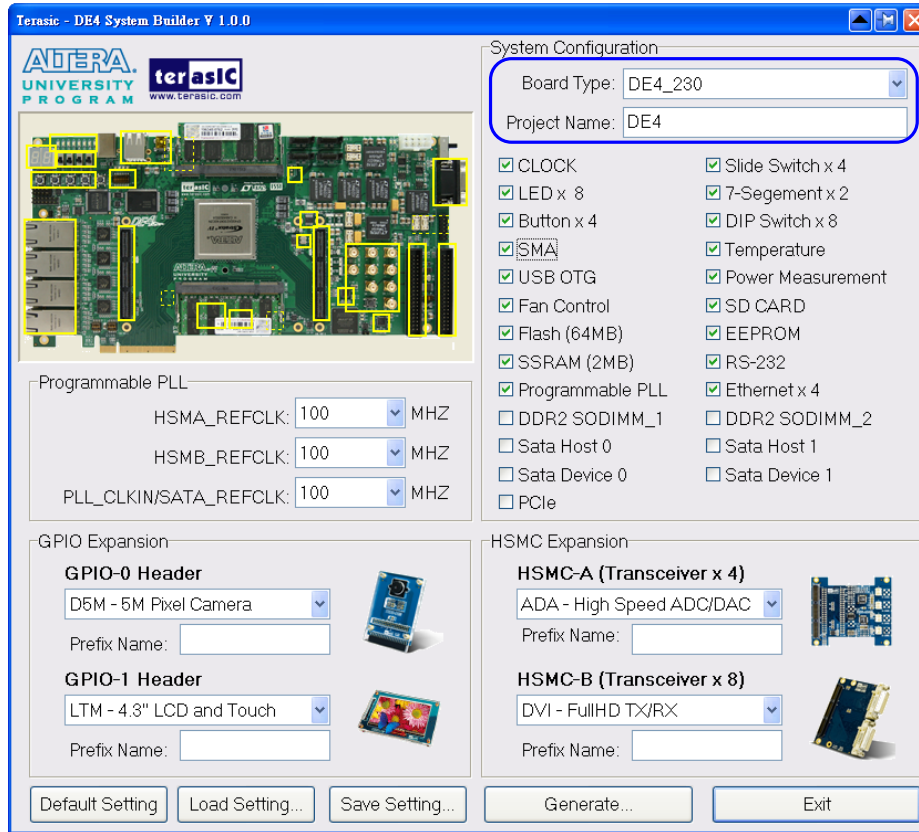

Figure 4–3 The DE4 Board Type and Project Name

■ System Configuration

Under System Configuration users are given the flexibility of enabling their choice of components on the DE4 as shown in **Figure 4–4**. Each component of the DE4 is listed where users can enable or disable a component according to their design by simply marking a check or removing the check in the field provided. If the component is enabled, the DE4 System Builder will automatically generate the associated pin assignments including the pin name, pin location, pin direction, and I/O standards.

Note. The pin assignments for some components for e.g. DDR2 and SATA require associated controller codes in the Quartus project otherwise Quartus will result in compilation errors. Therefore, do not select them if they are not necessary in your design. To use the DDR2 controller, please refer to the DDR2 SDRAM demonstration in Chapter 5.

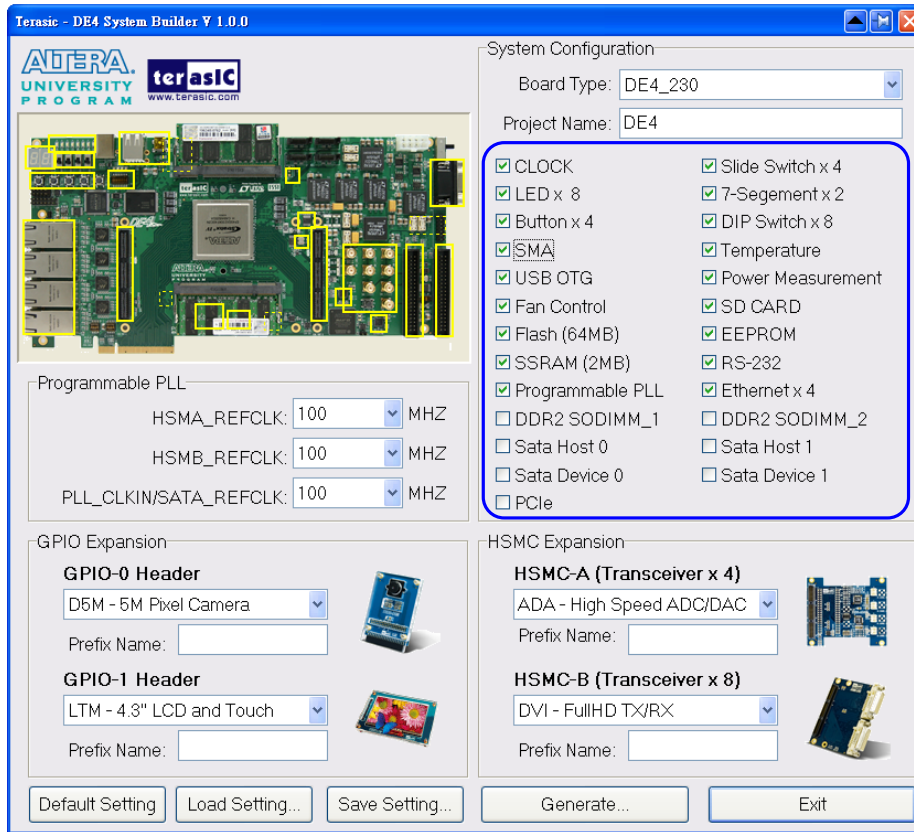

Figure 4–4 System Configuration Group

■ Programmable PLL

There are three external programmable PLLs on-board that provide reference clocks for the following signals HSMA_REFCLK, HSMB_REFCLK, and PLLCLKIN/SATA_REFCLK. To use these PLLs, users can select the desired frequency on the Programmable PLL group, as show in [Figure 4–5](#).

As the Quartus project is created, System Builder automatically generates the associated PLL configuration code according to users’ desired frequency in verilog which facilitates users’ implementation as no additional control code is required to configure the PLLs.

Note. If users need to dynamically change the frequency, they would need to modify the generated control code themselves.

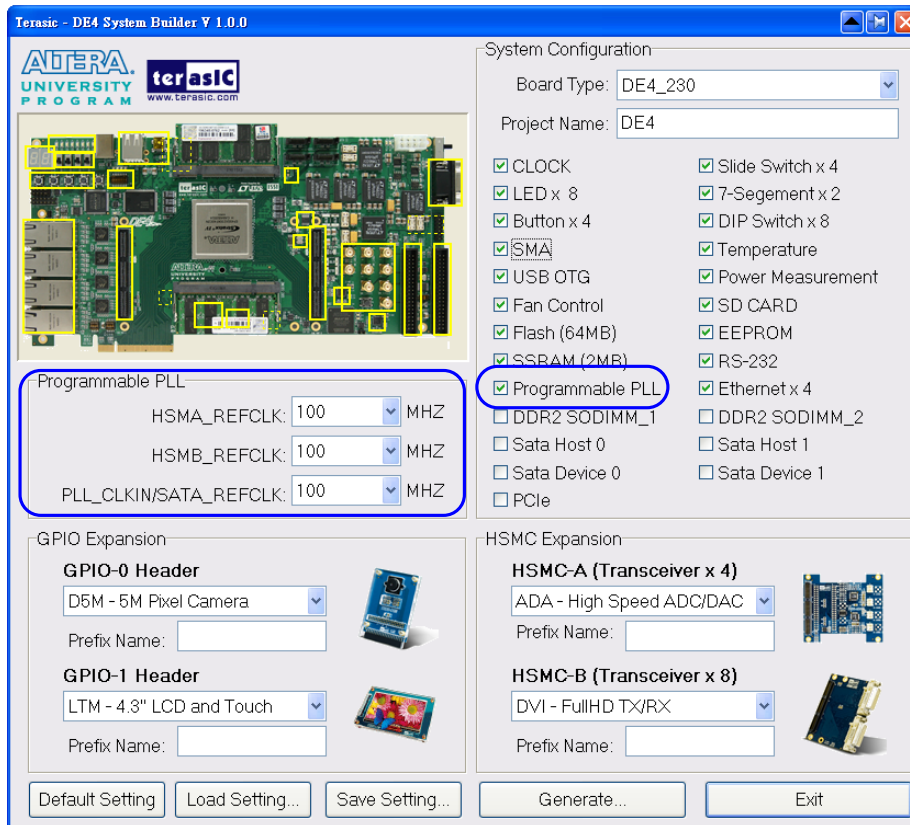

Figure 4-5 External Programmable PLL

■ GPIO Expansion

Users can connect GPIO expansion card onto either GPIO-0 header or the GPIO-1 header located on the DE4 board as shown in **Figure 4-6**. Select the daughter card you wish to add to your design under the appropriate GPIO header where the daughter card is connected to. The system builder will automatically generate the associated pin assignment including the pin name, pin location, pin direction, and IO standard.

If a customized daughter board is used, users can select “GPIO Default” followed by changing the pin name, pin direction, and IO standard according to the specification of the customized daughter board.

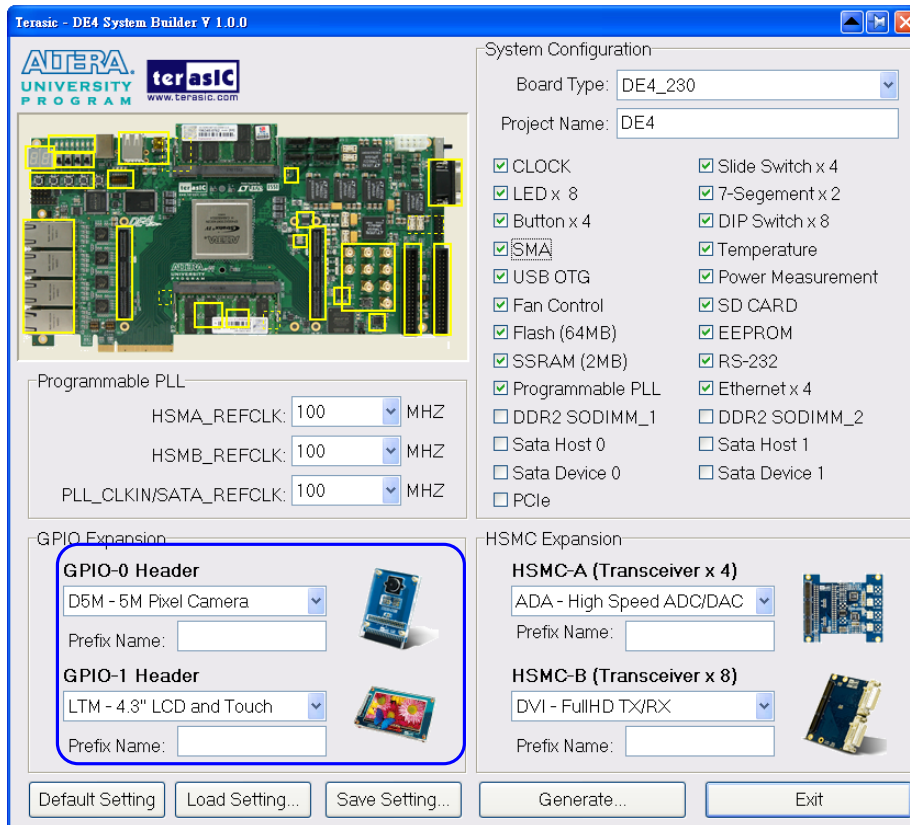

Figure 4–6 GPIO Expansion Group

The “Prefix Name” is an optional feature which denotes the pin name of the daughter card assigned in your design. Users may leave this field empty.

Note. If the same GPIO expansion card is selected under GPIO-0 and GPIO-1, a prefix name is required to avoid pin name duplication as shown in **Figure 4–7**, otherwise System Builder will prompt an error message.

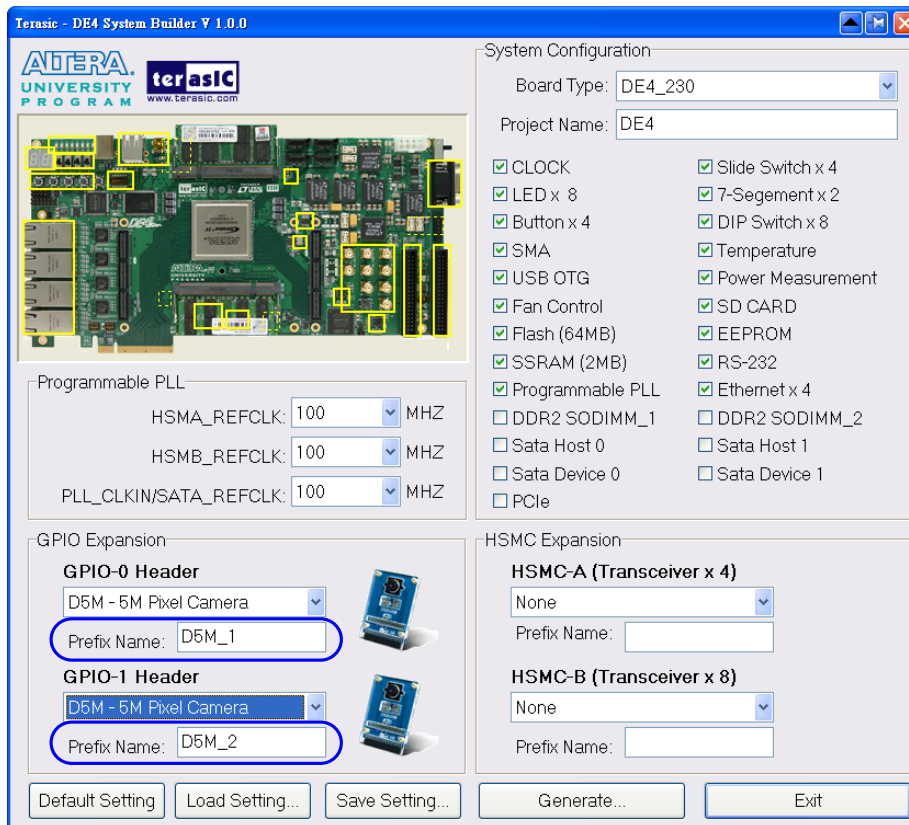

Figure 4–7 Specify Prefix Name for GPIO Expansion Board

■ HSMC Expansion

Users can connect HSMC-interfaced daughter cards onto either HSMC-A or HSMC-B located on the DE4 board shown in **Figure 4–8**. Select the daughter card you wish to add to your design under the appropriate HSMC connector where the daughter card is connected to. The System Builder will automatically generate the associated pin assignment including pin name, pin location, pin direction, and IO standard.

If a customized daughter board is used, users can select “HSMC Default” followed by changing the pin name, pin direction, and IO standard according to the specification of the customized daughter board. If transceiver pins are not required on the daughter board, please remember to remove it, otherwise Quartus will report errors.

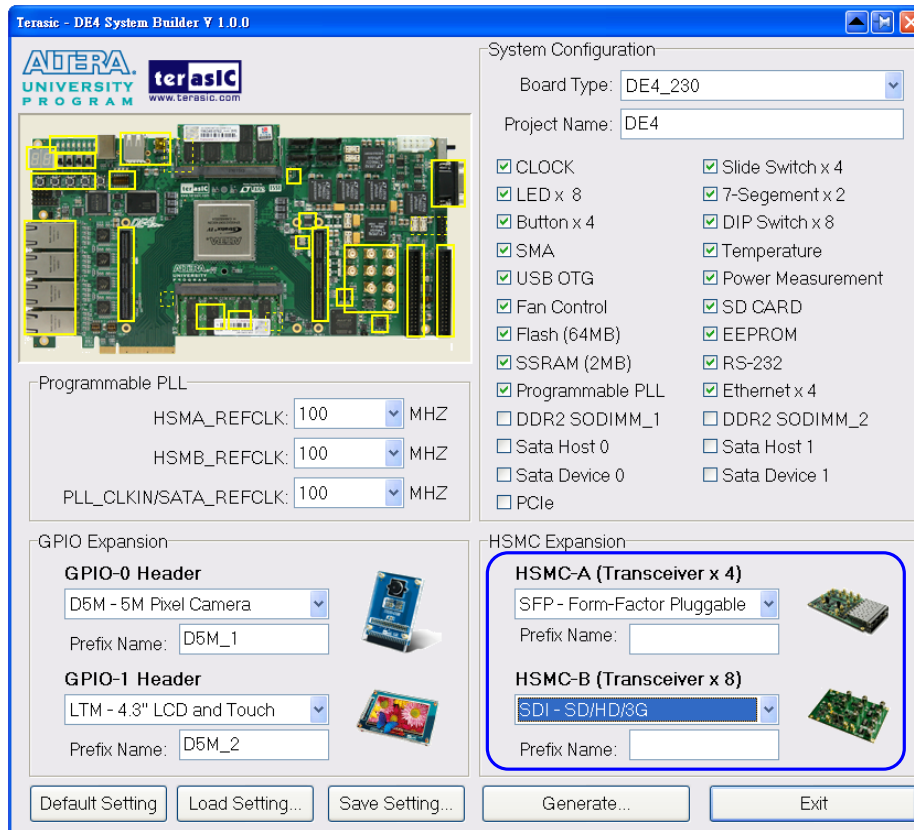

Figure 4–8 HSMC Expansion Group

The “Prefix Name” is an optional feature that denotes the pin name of the daughter card assigned in your design. Users may leave this field empty.

Note, if the same HSMC daughter card is selected in both HSMC-A and HSMC-B expansion, a prefix name is required to avoid pin name duplication as shown in **Figure 4–9**, otherwise System Builder will prompt an error message.

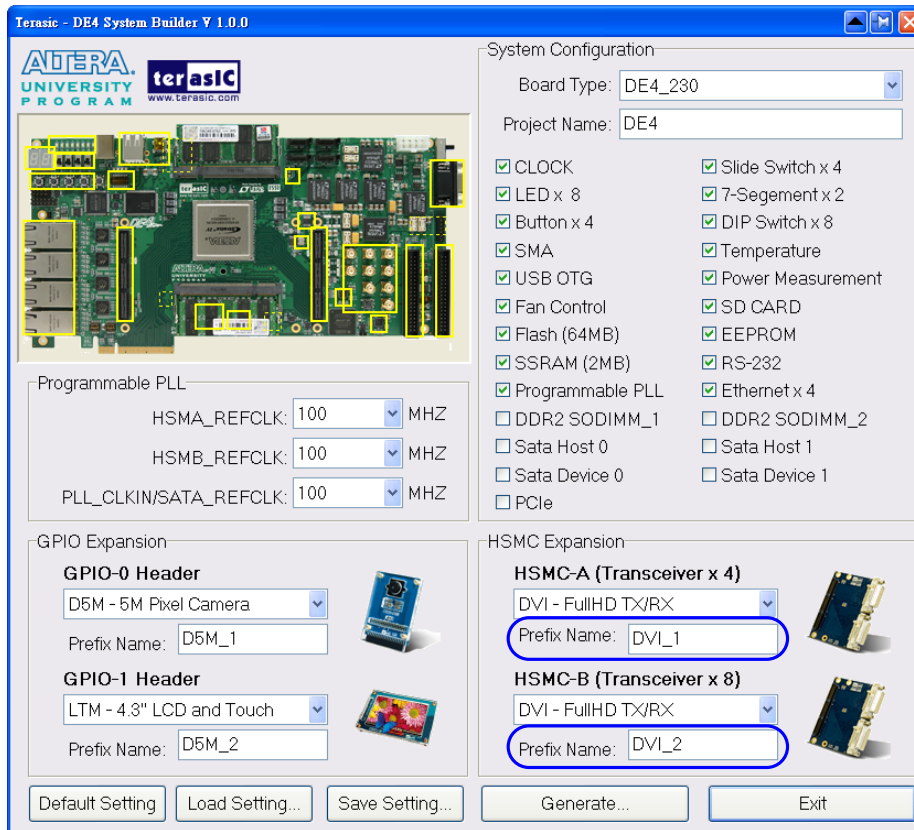

Figure 4–9 Specify Prefix Name for HSMC Expansion Board

■ Project Setting Management

The DE4 System Builder also provides functions to restore default setting, loading a setting, and saving users' board configuration file shown in **Figure 4–10**. Users can save the current board configuration information into a .cfg file and load it to the DE4 System Builder.

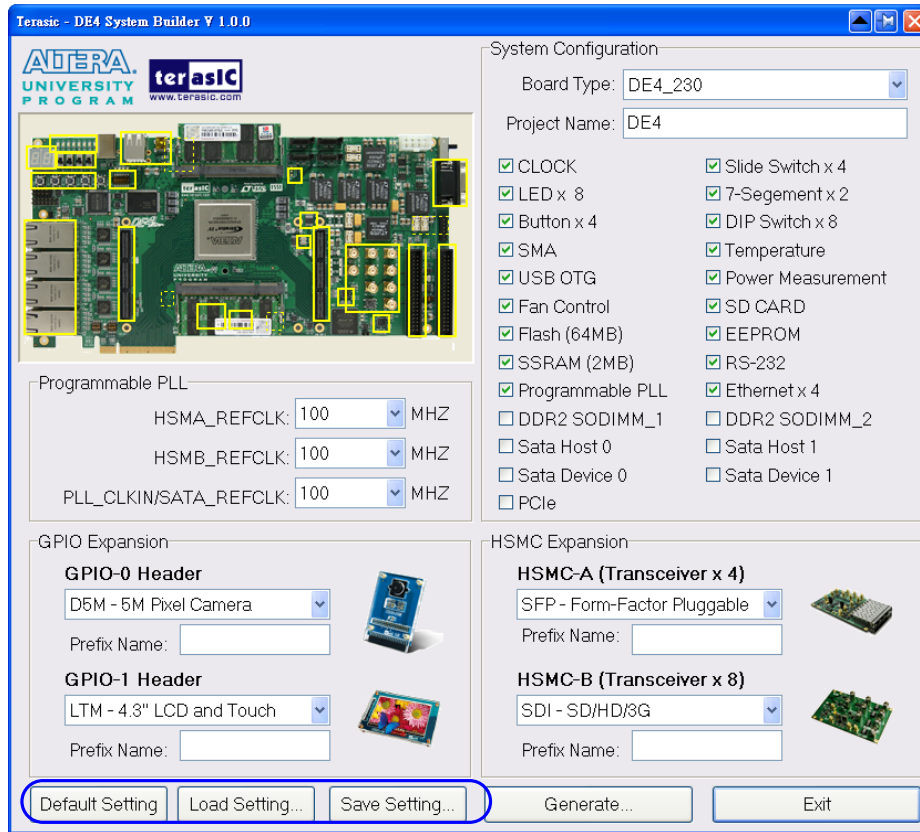

Figure 4–10 Project Settings

■ Project Generation

When users press the **Generate** button, the DE4 System Builder will generate the corresponding Quartus II files and documents as listed in the **Table 4–1** in the directory specified by the user.

Table 4–1 The files generated by DE4 System Builder

No.	Filename	Description
1	<Project name>.v	Top level verilog file for Quartus II
2	EXT_PLL_CTRL.v	External PLL configuration controller IP
3	<Project name>.qpf	Quartus II Project File
4	<Project name>.qsf	Quartus II Setting File
5	<Project name>.sdc	Synopsis Design Constraints file for Quartus II
6	<Project name>.htm	Pin Assignment Document

Users can use Quartus II software to add custom logic into the project and compile the project to generate the SRAM Object File (.sof).

In addition, External Programmable PLL Configuration Controller IP will be instantiated in the Quartus II top-level file as listed below:

```

ext_pll_ctrl ext_pll_ctrl_Inst(
    .osc_50(OSC_50_BANK2), //50MHZ
    .rstn(rstn),

    // device 1 (HSMA_REFCLK)
    .clk1_set_wr(clk1_set_wr),
    .clk1_set_rd(),

    // device 2 (HSMB_REFCLK)
    .clk2_set_wr(clk2_set_wr),
    .clk2_set_rd(),

    // device 3 (PLL_CLKIN/SATA_REFCLK)
    .clk3_set_wr(clk3_set_wr),
    .clk3_set_rd(),

    // setting trigger
    .conf_wr(conf_wr), // 1T 50MHz
    .conf_rd(), // 1T 50MHz

    // status
    .conf_ready(conf_ready),

    // 2-wire interface
    .max_sclk(MAX_I2C_SCLK),
    .max_sdat(MAX_I2C_SDAT)
);

```

If dynamic PLL configuration is required, users need to modify the code according to users' desired PLL behavior.

Chapter 5

Examples of Advanced Demonstration

This chapter introduces several advanced designs that demonstrate Stratix IV GX features using the DE4 board. The provided designs include the major features on board such as the SATA, HSMC, Gigabit Ethernet, SD card, USB host and device, and DDR2. For each demonstration the Stratix IV GX FPGA configuration file is provided, as well as full source code in Verilog HDL and C. All of the associated files can be found in the *DE4_demonstrations\de4_<Stratix device>* folder from the **DE4 System CD**.

For each of demonstrations described in the following sections, we give the name of the project directory for its files, which are sub-directories of the *DE4_demonstrations\de4_<Stratix_device>* folder.

5.1 USB Host

USB (Universal Serial Bus) is a well-known communication standard used in many peripherals. The DE4 board provides a complete USB solution for both host and device applications. In this demonstration, USB host functions are implemented for USB mass-storage and Human-interface devices (HIDs) including a USB-Mouse. The drivers of the above applications are implemented in NIOS II C code. All high-speed, full-speed, and low-speed devices are supported in this demonstration.

Figure 5–1 shows the hardware system block diagram of this demonstration. The system requires a 50 MHz clock provided from the board. The PLL generates a 100 MHz clock for NIOS II processor and high-speed controllers, as well as a 10 MHz clock for low-speed peripherals such as buttons. A custom-defined SOPC ISP1761 controller, developed by TERASIC, is used to connect the ISP1761

USB chip and NIOS II processor. Based on this controller, NIOS II processor can access the register, memory, and interrupts of the USB chip. A PIO pin, named `usb_reset_n`, is connected to the USB for performing hardware reset of the USB chip. The NIOS II program is stored in the On-Chip Memory.

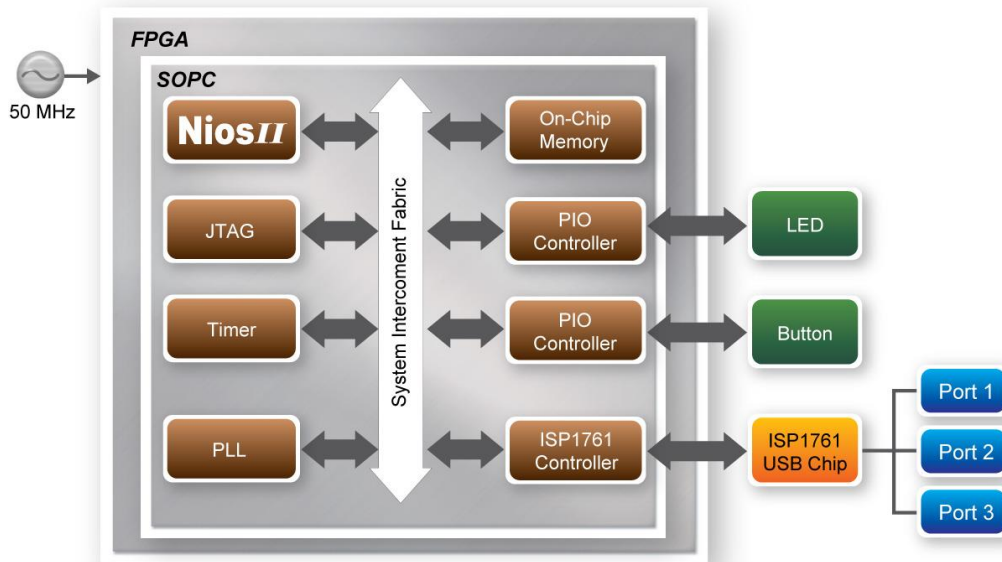

Figure 5–1 Hardware block diagram of the USB-Host demonstration

■ Nios II Software Architecture

Figure 5–2 shows the architectural layers of a NIOS II software stack of this demonstration.

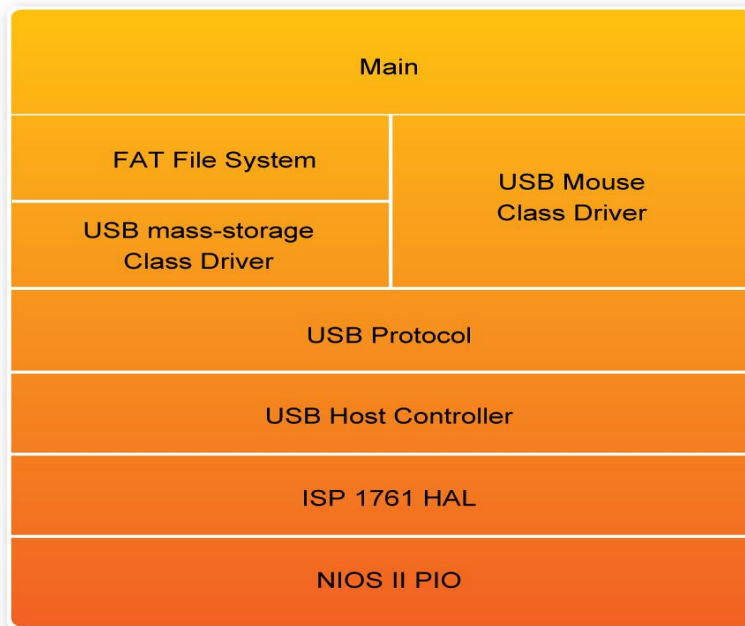

Figure 5–2 Software stack of the USB-Host demonstration

Each block encapsulates the specific implementation details of that block, providing a data abstraction for the block above. The following is a description of each block:

Nios II PIO – The Nios PIO block provided by Nios II system that supports basic IO functions IORD and IOWR to access hardware directly. The function prototypes are defined in the header file <io.h>.

ISP 1761 HAL – The ISP 1761 HAL block implements functions to access internal registers and memories of the USB chip ISP 1761, and high/full/low speed transfer functions for isochronous, interrupt, control, and bulk transfers.

USB Host Controller – The USB host controller block implements control functions for ISP1761 host controller.

USB Protocol – The USB protocol block implements USB protocol including USB-Hub protocol.

USB-Mouse Class Driver – The USB-mouse class driver implements functions to communicate with HID USB-mouse.

USB mass-storage Class Driver – The USB mass-storage Class Driver implements functions to communicate with Bulk-Only Transport USB mass-storage based on “USB Floppy Interface” (UFI)

command set. UFI is defined based on the SCSI-2 and SFF-8070i command set.

FAT File System – The FAT file system block implements reading functions for FAT16 and FAT32 file system. Long filename is supported in this function block.

Main – the main block contains the tasks for the application including reading the commands and write functions to the computer.

The workflow of the main block is shown in **Figure 5–3**. The standard output of this program is JTAG-UART. In the demo batch file, the output message will be display in nios2-terminal. When the program detects an USB mass-storage device, it will list the files in root directory. If a file named “test.txt” is found, the program will dump the file contents. When an HID USB-Mouse is detected, the program will poll the mouse status continuously and display the relative information in standard output.

In this demonstration, NIOS II uses PIO mode to access the internal memory of ISP1761. For high throughput application, DMA implementation and interrupt can enhance data transfer rate significantly.

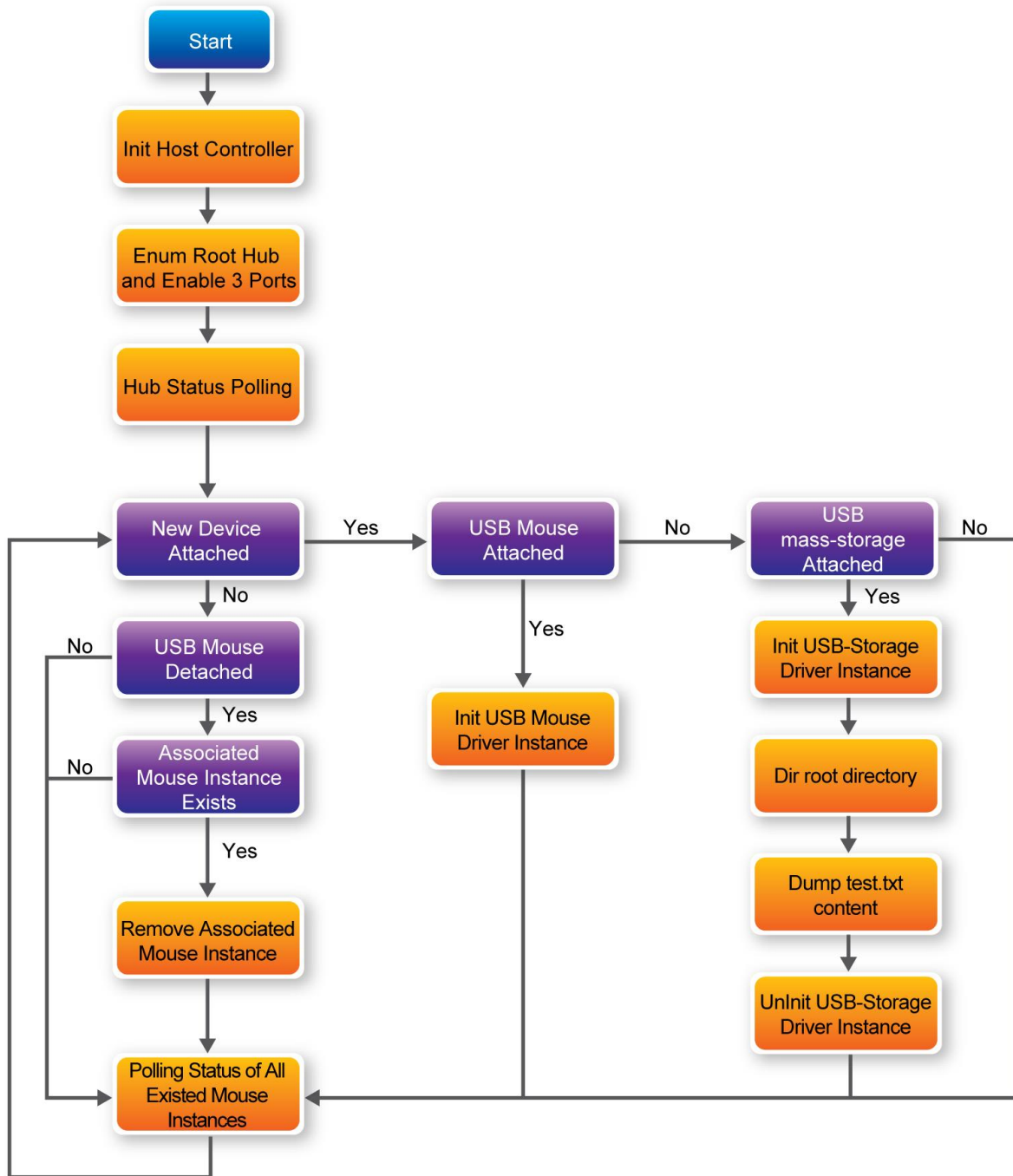

Figure 5-3 Software workflow of the USB-Host demonstration

■ Design Tools

- Quartus II
- NIOS II IDE

■ Demonstration Source Code

- Quartus II Project directory: *DE4_USB*
- FPGA Bit Stream: *DE4_USB.sof*
- NIOS II Workspace: *DE4_USB\Software\Project_Usb_Host*

The NIOS II source code list is shown in **Figure 5–4**. Users can modify *terasic_debug.h* to configure the debug message. Note, the debug message may affect the USB performance, and possibly cause malfunction to the demonstration.

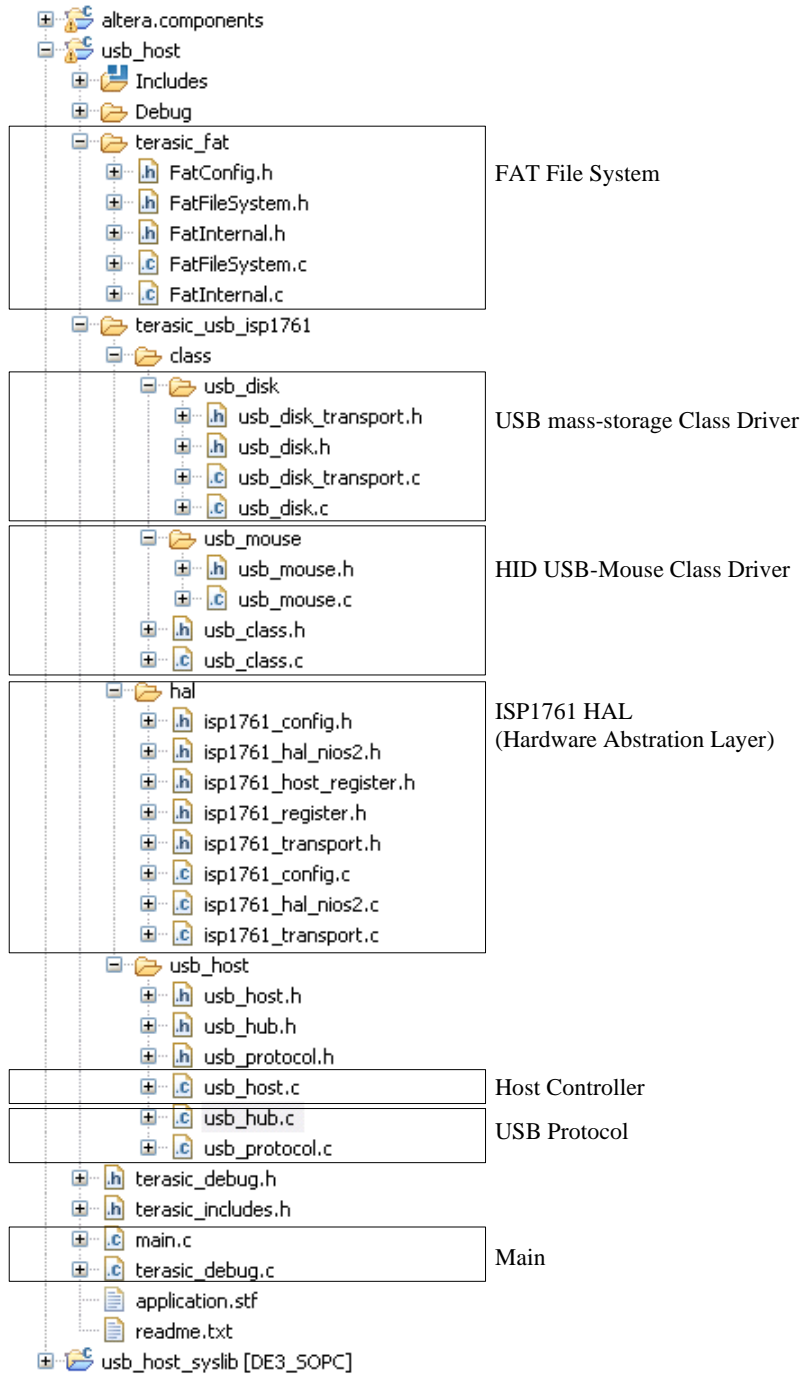

Figure 5–4 Source code list of the USB-Host demonstration

■ Nios II IDE Project Compilation

- Before you attempt to compile the reference design under Nios II IDE, make sure the project is cleaned first from the ‘Project’ menu of Nios followed by ‘Clean’.

■ Demonstration Batch File

Demo Batch File Folder: DE4_USB \Demo_Batch\usb_host

The demo batch file folders include the following files:

- Batch File: test.bat, test_bashrc
- FPGA Configuration File: *DE4_USB.sof*
- NIOS II Program: *usb_host.elf*

■ Demonstration Setup

- Make sure Quartus II and NIOS II are installed.
- Power on DE4.
- Connect USB cable to DE4. The PC will need to install the USB Blaster driver for the first time use.
- Execute the demo batch file “test.bat” under the batch file folder, DE4_USB\demo_batch\usb_host
- The LED (D13-D15) of the three USB ports will be light after USB ports are configured completed.
- For USB mass-storage demonstration, copy test files to the root directory of USB-Disk.
- Plug USB mass-storage device or HID USB-Mouse into the USB ports in DE4, as shown in [Figure 5-5](#).
- The device information will be displayed in nios2-terminal, as shown in [Figure 5-6](#).

■ Reference

- ISP1761 Hi-Speed Universal Bus On-The-Go controller, Rev. 04 – 5 March 2007.
- Universal Serial Bus Specification, Revision 2.0, April 27, 2000.
- Enhanced Host Controller Interface Specification for Universal Serial Bus, Revision 1.0, March 12, 2002.
- Universal Serial Bus Mass Storage Class, Bulk-Only Transport, Revision 1.0, September 31, 1999.
- Universal Serial Bus Mass Storage Class, UFI Command Specification, Revision 1.0, December 14, 1998.

- Universal Serial Bus, Device Class Definition for Human Interface Devices (HID), Version 1.11, June 27, 2001.

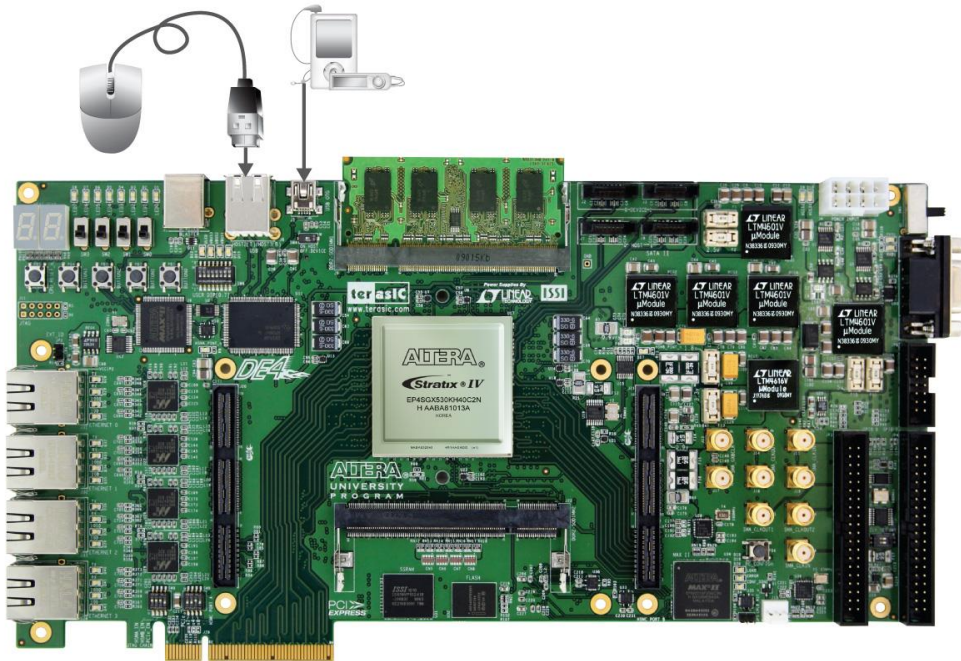

Figure 5-5 Plug USB-Devices into DE4

```

C:\> Nios II EDS 9.1

-----
Welcome to the Nios II Embedded Design Suite
Version 9.1, Built Thu Oct 22 02:02:11 PDT 2009

Example designs can be found in
  /cygdrive/c/altera/91/nios2eds/examples

-----
<You may add a startup script: c:/altera/91/nios2eds/user.bashrc>
Using cable "USB-Blaster [USB-01]", device 1, instance 0x00
Resetting and pausing target processor: OK
Initializing CPU cache <if present>
OK
Downloaded 98KB in 1.7s <57.6KB/s>
Verified OK
Starting processor at address 0x011201C8
nios2-terminal: connected to hardware target using JTAG UART on cable
nios2-terminal: "USB-Blaster [USB-01]", device 1, instance 0
nios2-terminal: <Use the IDE stop button or Ctrl-C to terminate>

[APP]==== DE4 ISP1761 USB Host Demo [03/11/2010]====
[APP]Please insert USB-Storage or/and HID USB-Mouse
[APP]Device attach at port 2, Speed=Low Speed, DeviceType=USB-Mouse
[APP]Port[2] Mouse:x=0, y=0, Left Button Pressed
  
```

Figure 5-6 Display device information

5.2 USB Device

Most USB applications and products operate as USB devices, rather than USB hosts. This demonstration will show how the DE4 board is operated as a USB device by connecting it to a host computer. In this demonstration, the USB port 1 (mini-AB port) on the DE4 is configured as a device port to connect with a host computer. The NIOS II processor communicates with host computer through USB Bulk Transfer with user-defined command sets. The USB device driver is implemented in NIOS C code. From the host computer side, a test program is used to communicate with DE4. The test program can configure LED status and poll button status through the USB connection.

■ Nios II Software Architecture

The hardware system block diagram of this demonstration is the same as the USB Host. **Figure 5-7** shows the architectural layers of a NIOS II software stack of this demonstration.

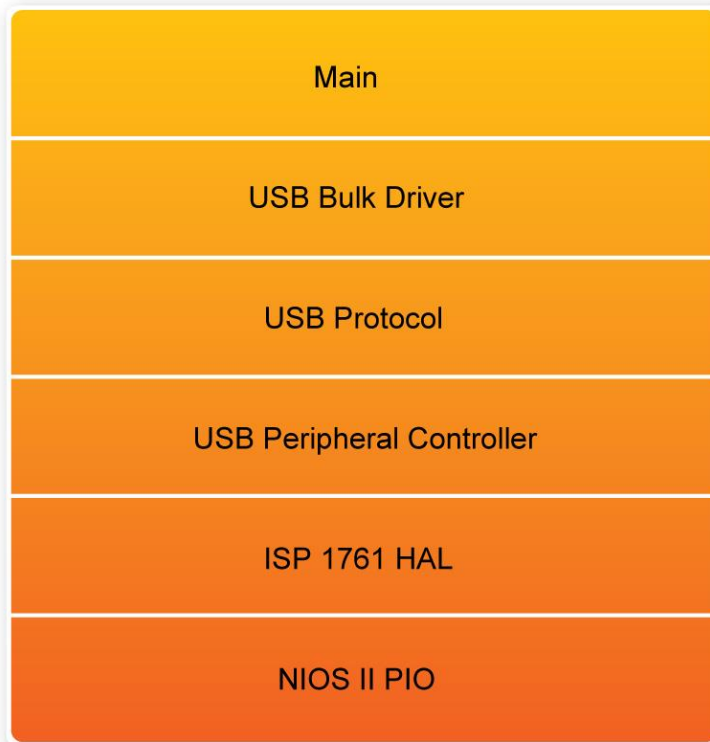

Figure 5-7 Software stack of the USB-Device demonstration

Each block encapsulates the specific implementation details of that block, providing a data abstraction for the block above. The following is a description of each block:

Nios II PIO – The Nios PIO block provided by Nios II system that supports basic IO functions IORD and IOWR to access hardware directly. The function prototypes are defined in the header file <io.h>.

ISP 1761 HAL – The ISP 1761 HAL block implements functions to access internal control/data registers of the USB chip ISP 1761.

USB Peripheral Controller – The USB peripheral controller block implements control functions for ISP1761 peripheral controller.

USB Protocol – The USB protocol block implements USB protocol including USB-Hub protocol.

USB Bulk Driver – The USB bulk driver implements a device driver to provide two bulk end-points, namely Bulk-In and Bulk-Out.

Main – the main block is implemented to communicate with a host computer. It calls bulk-read functions to receive commands from the host computer, and calls bulk-write function to return data to the host computer.

From the host computer, a test program named `Terasic_UsbControl.exe` is used to communicate with the DE4, as shown in **Figure 5–8**. Users that are connecting the DE4 USB device port for the first time, a dialog window will appear requesting a USB driver to be installed. The driver is available in the current demo folder, named `terasic_usb.sys` and `terasic_usb.inf`. After the driver is installed, users can launch the test program to communicate with the DE4.

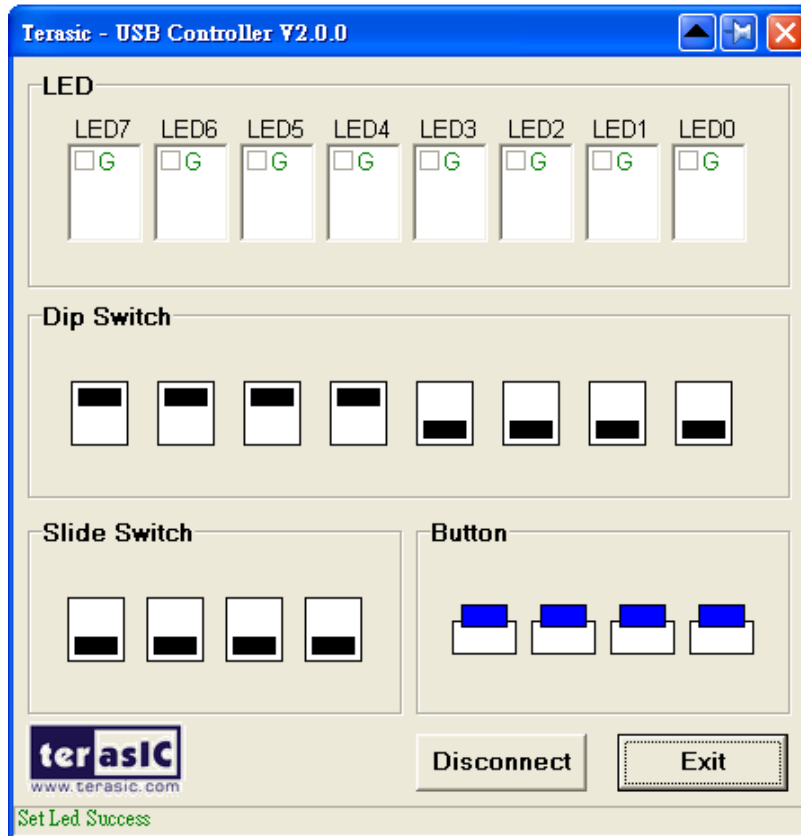

Figure 5–8 User interface of the Terasic_UsbControl.exe

■ Design Tools

- Quartus II
- NIOS II IDE

■ Demonstration Source Code

- Quartus Project directory: *DE4_USB*
- FPGA Bit Stream: *DE4_USB.sof*
- NIOS II Workspace: *DE4_USB\Software\Project_Usb_Device*

The NIOS II source code list is shown in [Figure 5–9](#). Users can modify *terasic_debug.h* to configure the debug message. Note that any debug message may affect the USB performance, or even cause malfunction in this demonstration.

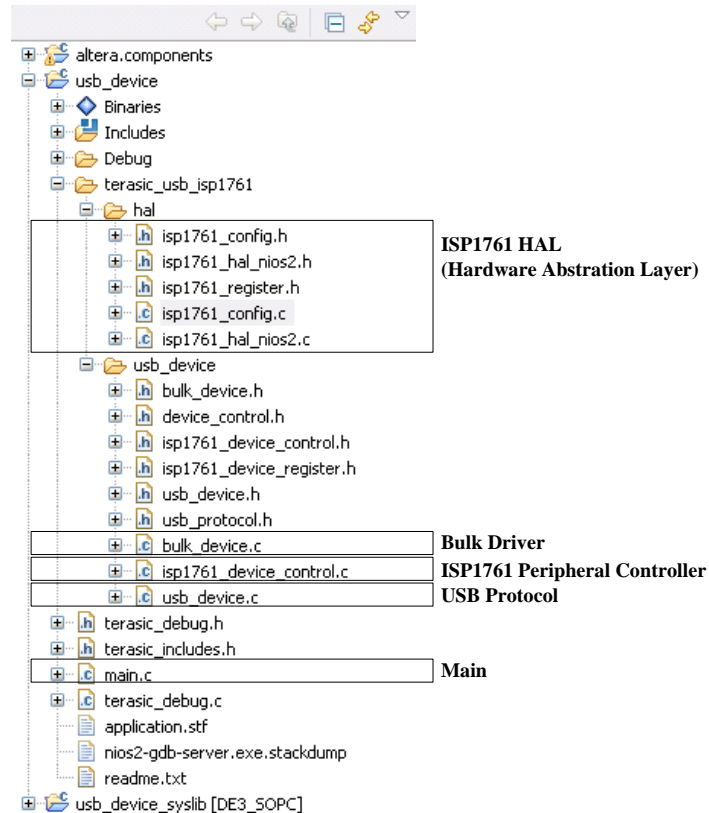

Figure 5–9 Source Code List of the USB-Device Demonstration

■ Nios II IDE Project Compilation

- Before you attempt to compile the reference design under Nios II IDE, make sure the project is cleaned first from the ‘Project’ menu of Nios followed by ‘Clean’.

■ Demonstration Batch File

Demo Batch File Folder: DE4_USB \demo_batch\usb_device

The demo batch file includes the following files:

- Batch File: test.bat, test_bashrc
- FPGA Configure File: *DE4_USB.sof*
- NIOS II Program: *usb_device.elf*
- USB Driver for Windows XP: terasic_usb.sys and terasic_usb.inf
- USB Test Program for Windows XP: *Terasic_UsbControl.exe*

■ Demonstration Setup

- It is suggested to run this demonstration under Windows XP.
- Make sure Quartus II and NIOS II are installed.
- Power on the DE4 board.
- Connect USB Blaster to DE4 board and install USB Blaster driver if necessary.
- Execute the demo batch file “*test.bat*” under the batch file folder, *DE4_USB\demo_batch\usb_device*.
- Users may remove the USB Blaster once the FPGA configuration is completed.
- Connect USB cable from a host computer to the mini-AB port in DE4, as shown in **Figure 5–10**.
- For the first time the USB port of the host computer is connected to the mini-AB port of the DE4 board, a dialog will pop up to request a USB driver to be installed. The required driver is available in the demo batch folder, *DE4_USB\demo_batch\usb_device*.
- Launch *Terasic_UsbControl.exe* under the batch file folder, *DE4_USB\demo_batch\usb_device*.
- Click “**Connect**” in *DE4_UsbControl* window.
- After connection established, the button status on the DE4 will be updated to the program interface, and users can start to configure the LED status now.

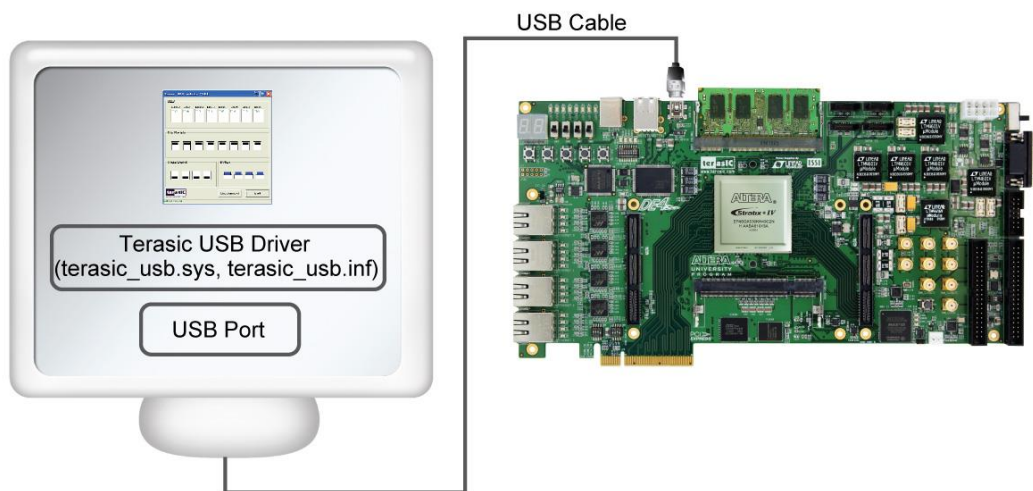

Figure 5–10 Connect USB ports for the USB-Device demonstration

5.3 Ethernet – Simple Socket Server

The Stratix IV GX device on the DE4 consists of built-in serializer/deserializer (SERDES) circuitry

for high-speed LVDS interfaces to support Gigabit Ethernet. Ethernet has been the dominant networking protocol providing a simple, cost-effective option for backbone and server connectivity. Gigabit Ethernet builds on top of the Ethernet protocol with speed up to 1000 Mbps, or 1 gigabit per second (Gbps). In this demonstration, we will illustrate how to create a simple socket server generated in Nios II using the Gigabit Ethernet devices equipped on the DE4 board. As indicated in the block diagram in **Figure 5–11**, the Nios II processor is used to communicate with the client via Marvell 88E1111 Ethernet Transceiver.

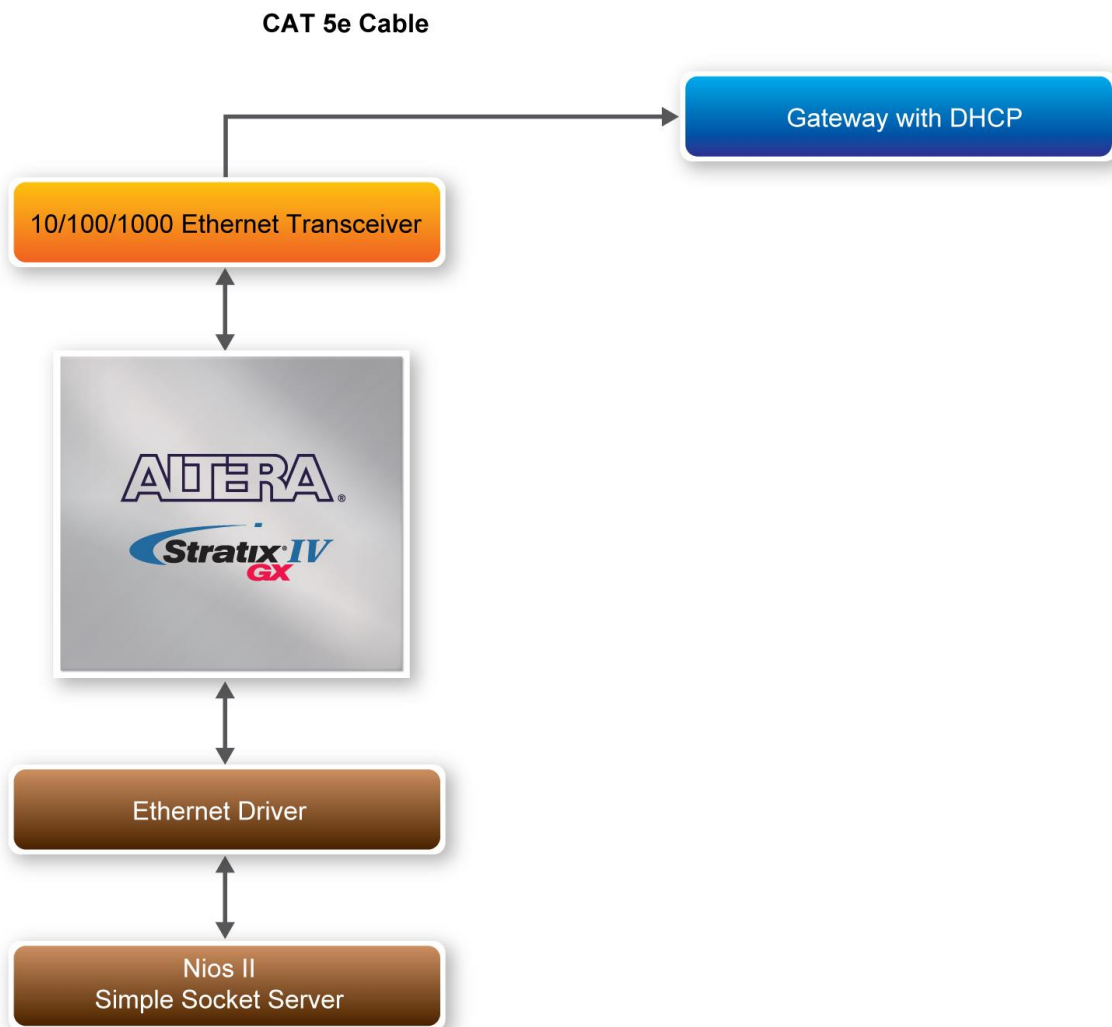

Figure 5–11 Block diagram of the Ethernet demonstration

Part of Nios II, NicheStack TCP/IP Network Stack is a software suite of networking protocols designed to provide an optimal solution for designing network-connected embedded devices with the Nios II processor. A telnet client application is used to communicate with the Simple Socket

Server issuing commands over a TCP/IP socket to the Ethernet-connected NicheStack TCP/IP Stack running on the DE4 board with a Simple Socket Server. The Simple Socket Server continues to listen for commands on a TCP/IP port and operates the DE4 LEDs according to the commands from the telnet client. NicheStack TCP/IP stack uses the MicroC/OS-II RTOS multithreaded environment to provide immediate access to a stack for Ethernet connectivity for the Nios II processor. The Nios II processor system contains an Ethernet interface, or media access control (MAC)

■ How the Ethernet demonstration is built

In this following section we describe how to build the demonstration through the SOPC builder. The SOPC system includes the CPU processor, On-Chip memory, JTAG UART, system ID, timer, Triple-Speed Ethernet, Scatter-Gather DMA Controllers and peripherals which are linked together contained in the Nios II hardware system that are used when building a project. **Figure 5–12** presents the overall setup of the SOPC builder from the Ethernet Simple Socket Server project.

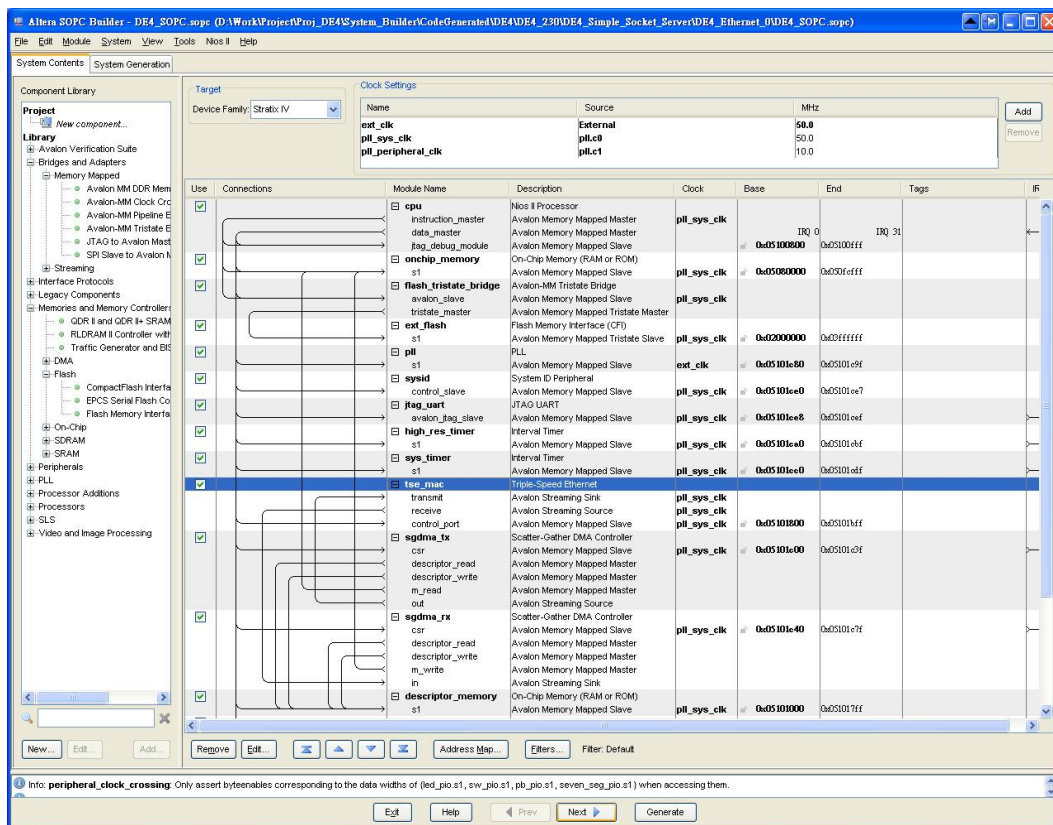

Figure 5–12 SOPC builder for Ethernet Simple Socket Server

In the Triple-Speed Ethernet IP Core configuration, the interface is set to SGMII as well as using the internal FIFO shown in **Figure 5–13**.

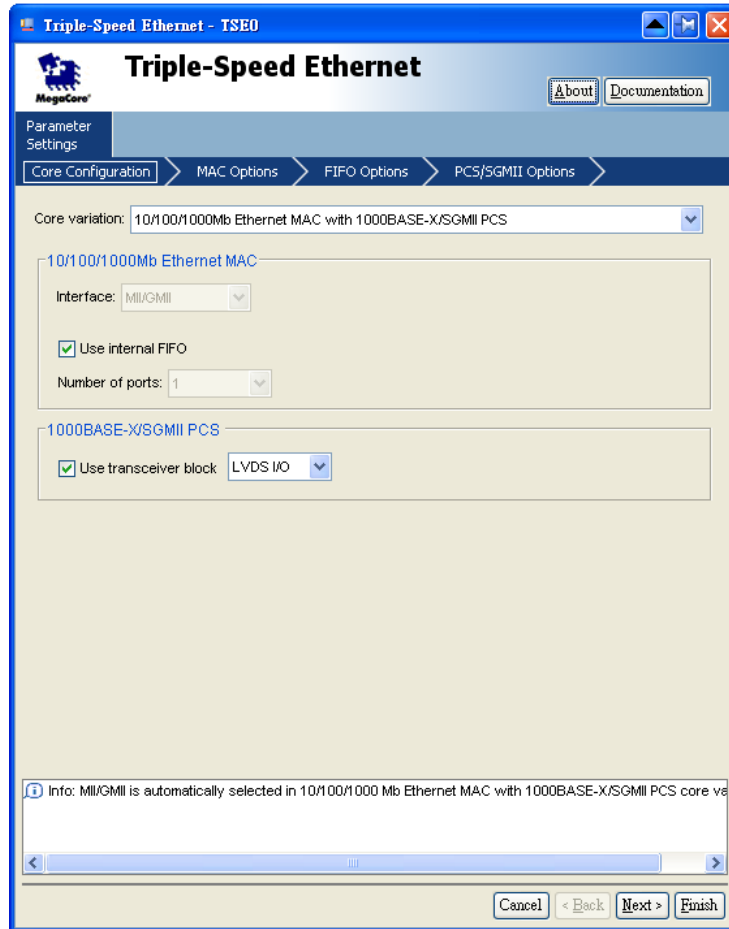

Figure 5–13 Triple-Speed Ethernet core configurations

In the MAC options section, the MDIO module is included that controls the PHY Management Module associated with the MAC block. The host clock divisor is to divide the MAC control register interface clock to produce the MDC clock output on the MDIO interface. The MAC control register interface clock frequency is 100 MHz and the desired MDC clock frequency is 2.5 MHz, a host clock divisor of 40 should be used. Once the Triple-Speed Ethernet IP configuration has been set and necessary hardware connections has been made click on ‘Generate’ to build the interconnect logic automatically.

In this following section we will describe the steps to create the Simple Socket Server using Nios II. We create a new project in Nios II using the project template, Simple Socket Server shown in **Figure 5–14**. The PTF file created using the SOPC builder in Quartus II is used in the Select Target Hardware section.

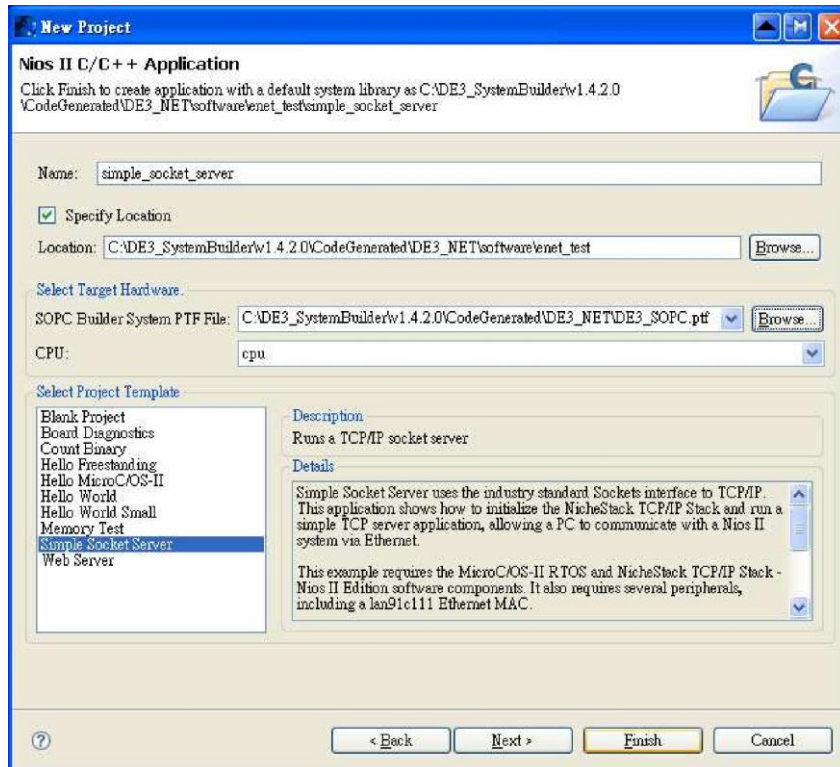

Figure 5–14 Nios II project simple socket server

■ Overview

The Simple Socket Server uses the industry standard sockets interface to TCP/IP. It uses DHCP protocol to requests a valid IP from the Gateway. During the device initialization process, the NichStack TCP/IP Stack system code calls `get_mac_add()` and `get_ip_add()` to get the MAC and IP addresses for the network interface.

Once the MAC address is generated, Autonegotiation is initiated where both connected devices, the Ethernet (Marvel 88E1111) and Gateway devices broadcasts its transmission parameters, speed and duplex mode. By default, the MAC interface for the Ethernet device is set to SGMII. In this demonstration, we are using SGMII MAC interface which can be configured through the management interface of the 88E1111 Ethernet device. Once the link is established an IP address is assigned to the Ethernet device along with the port number. Through TCP and port number, the demonstration uses Telnet client to establish connection with the Simple Socket Server, where it is continuously listening on the port. Once the connection is established between the Telnet client and Simple Socket Server, the Telnet client is able to send packets which are received by the Nios II processor and through the Simple Socket Server it will send server command to the DE4. The packet sent contains LED command which is extracted and dispatched to the LED command queue

for processing by the LED management tasks.

Figure 5–15 shows the software architecture of the Nios program for the Simple Socket Server. The top block containing the Nios II processor and the necessary hardware to be implemented into the DE4 board. The software device drivers contain the necessary device drivers needed for Ethernet and other hardware components to functions. The HAL API block provides the interface for the software device drivers, while the MicroC/OS-II provides communication services to the NicheStack and the Simple Socket Server. The NicheStack TCP/IP stack software block provides networking services to the application where it contains tasks for Simple Socket Server and also LED management.

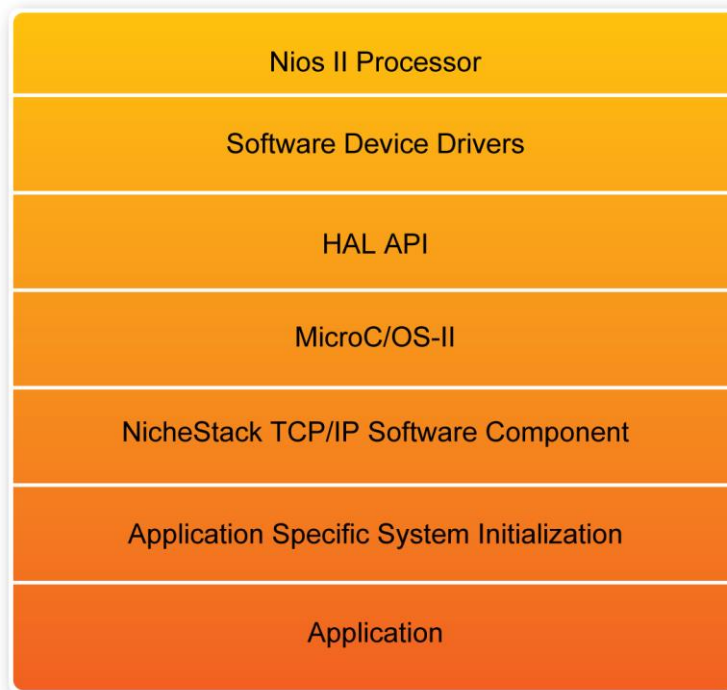

Figure 5–15 Nios program software architecture

■ Design Tools

- Quartus II
- NIOS II IDE

■ Demonstration Source Code

- Quartus Project directory: DE4_Simple_Socket_Server\DE4_Ethernet_<Ethernet Port #>

- FPGA Bit Stream: *DE4_Ethernet.sof*
- NIOS II Workspace: *DE4_Simple_Socket_Server\DE4_Ethernet_<Ethernet Port #>\software\simple_socket_server*

■ Nios II IDE Project Compilation

- Before you attempt to compile the reference design under Nios II IDE, make sure the project is cleaned first from the ‘Project’ menu of Nios followed by ‘Clean’.

■ Demonstration Batch File

- Demo Batch File Folder: *DE4_Simple_Socket_Server\de4_<Stratix device>_ethernet_test_batch\demo_batch_<Ethernet port #>*

The demo batch file folders include the following files:

- Batch File: *de4_net.bat*, *de4_net_bashrc*, *open_telnet.bat*
- FPGA Configuration File: *DE4_Ethernet.sof*
- NIOS II Program: *simple_socket_server.elf*

■ Demonstration Setup

- Make sure Quartus II and NIOS II are installed.
- Power on DE4.
- Connect USB cable to DE4. The PC will need to install the USB Blaster driver for the first time use.
- Execute the demo batch file “*de4_net.bat*” under the batch file folder, where the IP address and port numbers are assigned as shown below in **Figure 5–16**.

```

Nios II EDS 8.1
InterNiche Portable TCP/IP, v3.1

Copyright 1996-2008 by InterNiche Technologies. All rights reserved.
prep_tse_mac 0
Your Ethernet MAC address is 00:07:ed:12:34:56
prepped 1 interface, initializing...
[tse_mac_init]
INFO : TSE MAC 0 found at address 0x06002000
INFO : PHY Marvell 88E1111 found at PHY address 0x12 of MAC Group[0]
INFO : PHY[0.0] - Automatically mapped to tse_mac_device[0]
INFO : PHY[0.0] - Restart Auto-Negotiation, checking PHY link...
WARNING : PHY[0.0] - Auto-Negotiation FAILED
MARVELL : Enabling auto crossover
MARVELL : PHY reset
INFO : PHY[0.0] - Checking link...
INFO : PHY[0.0] - Link not yet established, restart auto-negotiation...
INFO : PHY[0.0] - Restart Auto-Negotiation, checking PHY link...
WARNING : PHY[0.0] - Auto-Negotiation FAILED
WARNING : PHY[0.0] - Link could not established
WARNING : PHY[0.0] - Auto-Negotiation not completed! Speed = 100, Duplex = Full
OK, x=0, CMD_CONFIG=0x00000000

MAC post-initialization: CMD_CONFIG=0x04000203
[tse_sgdma_read_init] RX descriptor chain desc (1 depth) created
mctest init called
IP address of et1 : 192.168.1.234
Created "inet main" task (Prio: 2)
Created "clock tick" task (Prio: 3)
DHCP timed out, going back to default IP address(es)

Simple Socket Server starting up
[ss_task] Simple Socket Server listening on port 30
Created "simple socket server" task (Prio: 4)

```

Figure 5-16 Simple socket server

- To establish connection, start the telnet client session by executing open_telnet.bat file and include the IP address assigned by the DHCP server-provided IP along with the port number as shown below in Figure 5-17.

```

C:\WINDOWS\system32\cmd.exe
Welcome to Microsoft Telnet Client
Escape Character is 'CTRL+I'
Microsoft Telnet> help
Commands may be abbreviated. Supported commands are:
c - close close current connection
d - display display operating parameters
o - open hostname [port] connect to hostname (default port 23).
q - quit exit telnet
set - set set options (type 'set ?' for a list)
sen - send send strings to server
st - status print status information
u - unset unset options (type 'unset ?' for a list)
?/h - help print help information
Microsoft Telnet> open 192.168.1.234 30_

```

Figure 5-17 Telnet Client

- From the Simple Socket Server Menu, enter the commands in the telnet session. Start the session by initializing the 7-segment displays by entering the letter “s” followed by a return where it begins incrementing. Entering a number from zero through six followed by a return causes the corresponding the LEDs (LED0-LED6) to toggle on or off on the DE4 board

5.4 SD Card Reader

Many applications use a large external storage device, such as a SD card or CF card, to store data. The DE4 board provides the hardware and software needed for SD card access. In this demonstration we will show how to browse files stored in the root directory of a SD card and how to read the file contents of a specific file. The SD card is required to be formatted as FAT File System in advance. Long file name is supported in this demonstration.

Figure 5–18 shows the hardware system block diagram of this demonstration. The system requires a 50 MHz clock provided from the board. The PLL generates a 100 MHz clock for the NIOS II processor and other controllers. Seven PIO pins are connected to the SD card socket. SD 4-bit Mode is used to access the SD card hardware. The SD 4-bit protocol and FAT File System function are all implemented by NIOS II software. The software is stored in the on-chip memory.

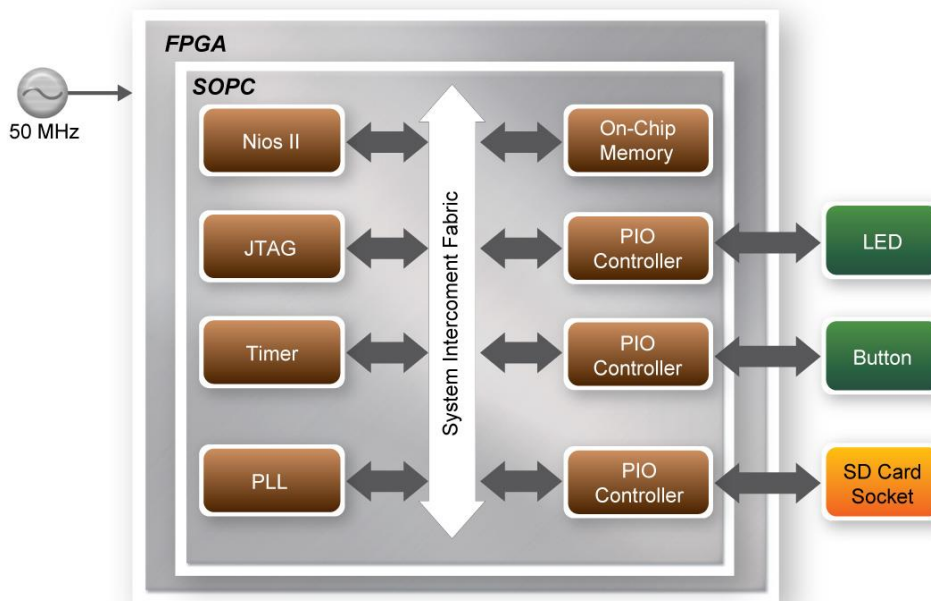

Figure 5–18 Block diagram of the SD card demonstration

Figure 5–19 shows the software stack of this demonstration. The NIOS PIO block provides basic IO functions to access hardware directly. The functions are provided from NIOS II system and the function prototype is defined in the header file `<io.h>`. The SD-CARD block implements SD 4-bit mode protocol for communication with SD cards. The FAT File System block implements reading function for FAT16 and FAT 32 file system. Long filename is supported. By calling the exported FAT functions, users can browse files under the root directory of the SD card. Furthermore, users can open a specified file and read the contents of the file.

The main block implements main control of this demonstration. When the program is executed, it detects whether a SD card is inserted. If a SD card is found, it will check whether the SD card is formatted as FAT file system. If a FAT file system is found, it searches all files in the root directory of the FAT file system and displays their names in the nios2-terminal. If a text file named “test.txt” is found, it will dump the file contents. If users press BUTTON3 of the DE4 board, the program will perform above process again.

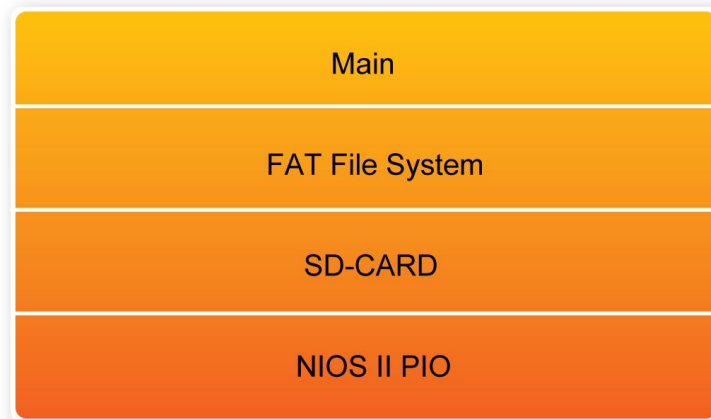

Figure 5–19 Software stack of the SD Card demonstration

■ Design Tools

- Quartus II
- NIOS II IDE

■ Demonstration Source Code

- Project directory: *DE4_SDCARD*
- Bit stream used: *DE4_SDCARD.sof*
- NIOS II Workspace: *DE4_SDCARD\Software*

■ Nios II IDE Project Compilation

- Before you attempt to compile the reference design under Nios II IDE, make sure the project is cleaned first from the 'Project' menu of Nios followed by 'Clean'.

■ Demonstration Batch File

Demo Batch File Folder: *DE4_SDCARD\Demo_Batch*

The demo batch file includes following files:

- Batch File: *test.bat*, *test_bashrc*
- FPGA Configure File: *DE4_SDCARD.sof*

- NIOS II Program: DE4_SDCARD.elf

■ Demonstration Setup

- Make sure Quartus II and NIOS II are installed on your PC.
- Power on the DE4 board.
- Connect USB Blaster to the DE4 board and install USB Blaster driver if necessary.
- Execute the demo batch file “*test.bat*” under the batch file folder, DE4_SDCARD\demo_batch.
- After NIOS II program is downloaded and executed successfully, a prompt message will be displayed in nios2-terminal
- Copy test files (text.txt) created by the user to the root directory of the SD Card.
- Insert the SD card into the SD Card socket of DE4, as shown in **Figure 5–20**.
- Press **Button3** of the DE4 board to start reading SD Card.
- The program will display SD Card information, as shown in **Figure 5–21**.



Figure 5–20 Insert SD Card for the SD-Card demonstration

clock provided from the board. The DDR2 controller is configured as a 1Gbytes DDR2-800 controller. The DDR2 IP generates one 400 MHz clock as SDRAM's data clock and one half-rate system clock 200 MHz for those controllers, e.g. NIOS processor, accessing the SDRAM. In the SOPC, NIOS and On-Chip Memory are designed running with the 200 MHz clock, and the other controllers are designed running with 10 MHz clock which is generated by the PLL. The NIOS program is running in the on-chip memory.

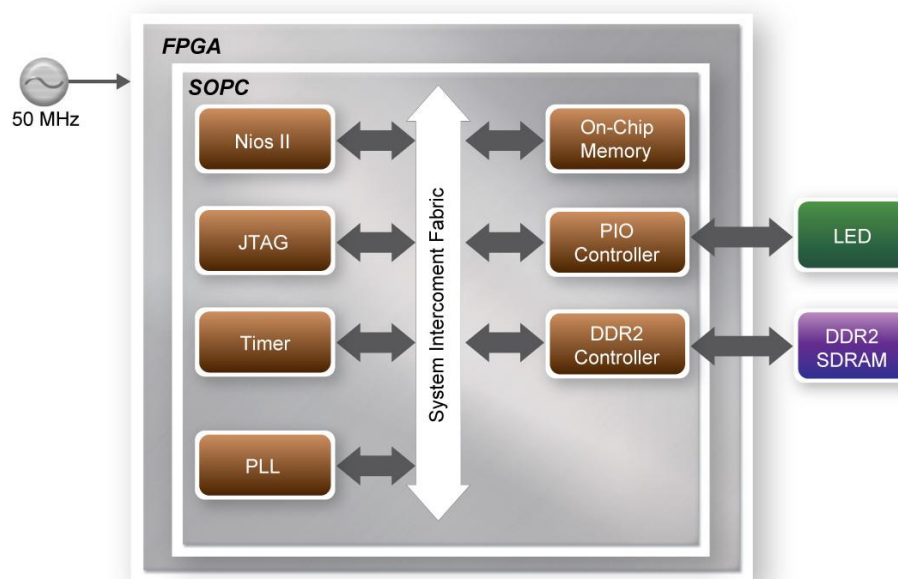

Figure 5–22 Block diagram of the DDR2 demonstration

The system flow is controlled by a NIOS program. First, the NIOS program writes test patterns into the whole 1GBytes SDRAM. Then, it calls NIOS system function, `alt_dache_flush_all`, to make sure all data has been written to SDRAM. Finally, it reads data from SDRAM for data verification. The program will show progress in JTAG-Terminal when writing/reading data to/from the SDRAM. When verification process is completed, the result is displayed in the JTAG-Terminal.

■ Altera DDR2 SDRAM High Performance Controller

To use Altera DDR2 controller, users need to perform three major steps: 1). Create correct pin assignment for DDR2. 2). Setup correct parameters in DDR2 controller dialog. 3). Execute TCL files, generated by DDR2 IP, under your Quartus project.

The following section describes some of the import issues in support of the DDR2 controller

configuration. On the “Memory_Setting” tab, in order to achieve 400 MHz clock frequency, a reference clock frequency of 50 MHz should be used which can be generated using a PLL. If a different DDR2 SODIMM is used, the memory parameters should be modified according to the datasheet of the DDR2 SODIMM. From the “PHY Settings” tab, both “Use differential DQS” and “Enable dynamic parallel on-chip termination” items should be selected.

■ Design Tools

- Quartus II
- NIOS II IDE

■ Demonstration Source Code

- Project directory: *DE4_DDR2*
- Bit stream used: *DE4_DDR2.sof*
- NIOS II Workspace: *DE4_DDR2\Software*

■ Nios II IDE Project Compilation

- Before you attempt to compile the reference design under Nios II IDE, make sure the project is cleaned first from the ‘Project’ menu of Nios followed by ‘Clean’.

■ Demonstration Batch File

Demo Batch File Folder: *DE4_DDR2\demo_batch\dim1* or *DE4_DDR2\demo_batch\dim2*

The demo batch file includes following files:

- DDR2 SODIMM 1
- Batch File: test.bat, test_bashrc
- FPGA Configure File: *DE4_DDR2.sof*
- NIOS II Program: *DE4_DDR2.elf*
- DDR2 SODIMM 2
- Batch File: test.bat, test_bashrc
- FPGA Configure File: *DE4_DDR2.sof*

- NIOS II Program: *DE4_DDR2.elf*

■ Demonstration Setup

- Make sure Quartus II and NIOS II are installed on your PC.
- Make sure DDR2-SDRAM SODIMM is installed on your DE4 board, as shown in **Figure 5–23**.
- Power on the DE4 board.
- Connect USB Blaster to the DE4 board and install USB Blaster driver if necessary.
- Execute the demo batch file “*test.bat*” under the batch file folder, *DE4_DDR2\demo_batch\dim1* or *DE4_DDR2\demo_batch\dim2*.
- After NIOS II program is downloaded and executed successfully, a prompt message will be displayed in nios2-terminal.
- Press **Button3~Button0** of the DE4 board to start SDRAM verify process. Press **Button0** for continued test and **Ctrl+C** to terminate the test
- The program will display progressing and result information, as shown in **Figure 5–24**.

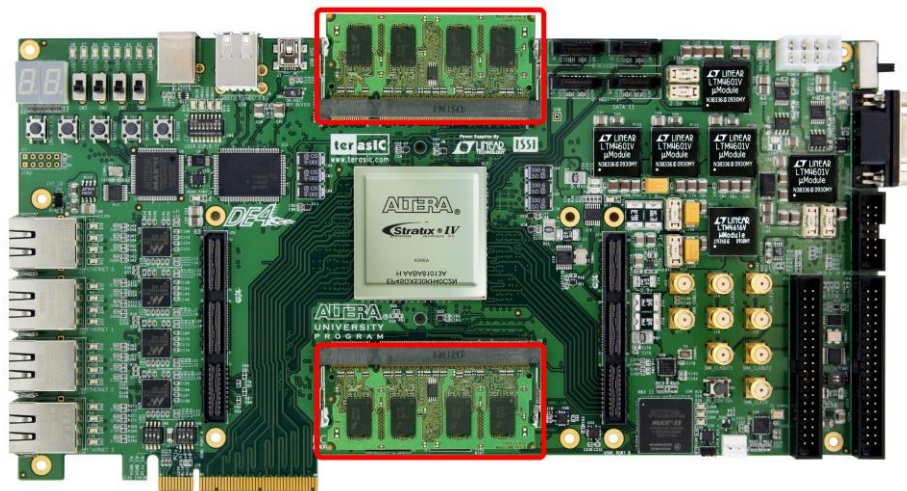

Figure 5–23 Insert DDR2-SDRAM SODIMM for the DDR2 Demonstration

```

C:\> Nios II EDS 9.1
Verified OK
Starting processor at address 0x410201C8
nios2-terminal: connected to hardware target using JTAG UART on cable
nios2-terminal: "USB-Blaster [USB-01]", device 1, instance 0
nios2-terminal: <Use the IDE stop button or Ctrl-C to terminate>

==== DE4 DDR2 Test Program ====
DDR2 Clock: 400 MHZ
DDR2 Size: 1024 MBytes
DDR2 Rank: 1 Rank(s)
DDR2 Bank: 3 Bank(s)
DDR2 Row: 14
DDR2 Col: 10

=====
Press any BUTTON to start test [BUTTON0 for continued test]
====> DDR2 Testing, Iteration: 1
write...
10% 20% 30% 40% 50% 60% 70% 80% 90% 100%
read/verify...
10% 20% 30% 40% 50% 60% 70% 80% 90% 100%
DDR2 test pass, size=1073741824 bytes, 71.922 sec
====> DDR2 Testing, Iteration: 2
write...
10% 20%

```

Figure 5–24 Display progress and result information for the DDR2 demonstration

5.6 External Clock Generator

The External Clock Generator provides designers using the 3 programmable clock generators via Texas Instruments chips (CDCM61001RHBT x 2, CDCM61004RHBT) the ability to specify the clock frequency individually, in addition addressing the input reference clock for the Stratix IV GX transceivers. The programmable clock is controlled by a control bus connected to the MAX II EPM2210 device. This can reduce the Stratix IV GX I/O usage while enabling greater functionality on the FPGA device. The MAX II EPM2210 device is capable of storing the last entered clock settings at which in the event the board restarts, the last known clock settings are fully restored. In this demonstration, we illustrate how to utilize the clock generators IP to define the clock output using the serial bus. The programmable clock output generates clock frequencies of 62.5, 75, 100, 125, 150, 156.25, 187.5, 200, 250, 312.5, and 625MHz for these clock signals:

- SATA_REFCLK/PLL_CLKIN (CDC61004RHBT)
- HSMA_REFCLK (CDCM61101/01)
- HSMB_REFCLK (CDCM61101/02)

Clock signals SATA_REFCLK and PLL_CLKIN are derived from the same programmable clock

generator (CDCM61004RHBT). Users designing SATA applications must use a 100MHz reference clock on the SATA_REFCLK signal which would lead to the same clock frequency applied to the PLL_CLKIN signal. At this stage any arbitrary changes to the PLL_CLKIN is not allowed as users can only change the PLL_CLKIN clock frequency if the SATA interface is not in use. The I/O standard for the three clock generators is set as LVDS which is non-configurable.

An overall block diagram of the external clock generator is shown below in **Figure 5–25**.

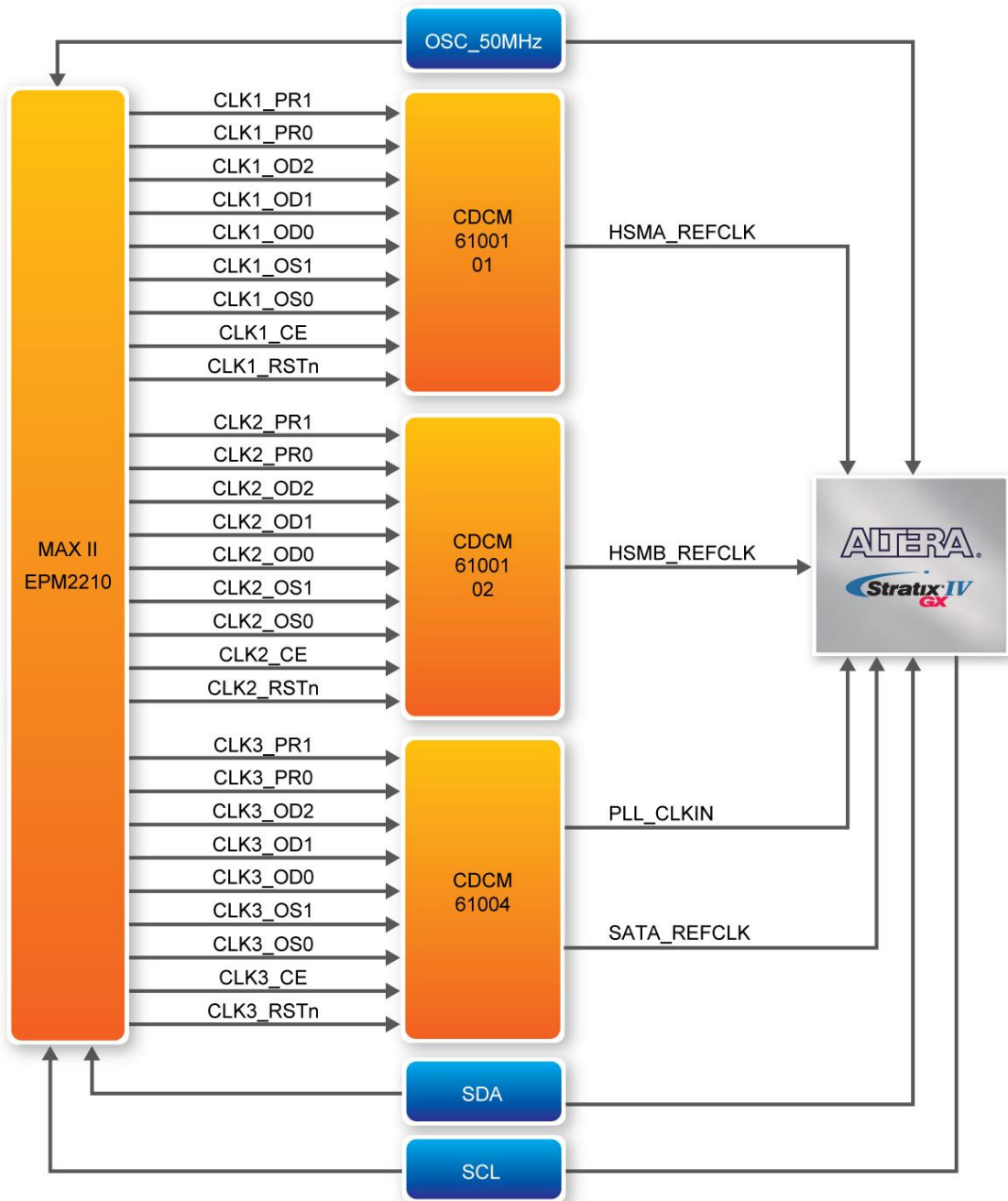

Figure 5–25 External Clock Generator Block Diagram

■ The EXT_PLL_CTRL IP Port Description

This section describes the operation for the EXT_PLL_CTRL instruction hardware port. **Figure 5–26** shows the EXT_PLL_CTRL instruction block diagram connected to the MAX II EPM2210 device. The EXT_PLL_CTRL controller module is defined by a host device, the Stratix IV GX

FPGA and a slave device, the MAX II EPM2210. Through the I2C bus interface the EXT_PLL_CTRL controller is able to control the Max II device by specifying the desire clock outputs set by the user. By changing the IP parameters of the Terasic EXT_PLL_CTRL IP, the external clock output frequency can be adjusted accordingly.

Table 5–1 lists the EXT_PLL_CTRL instruction ports.

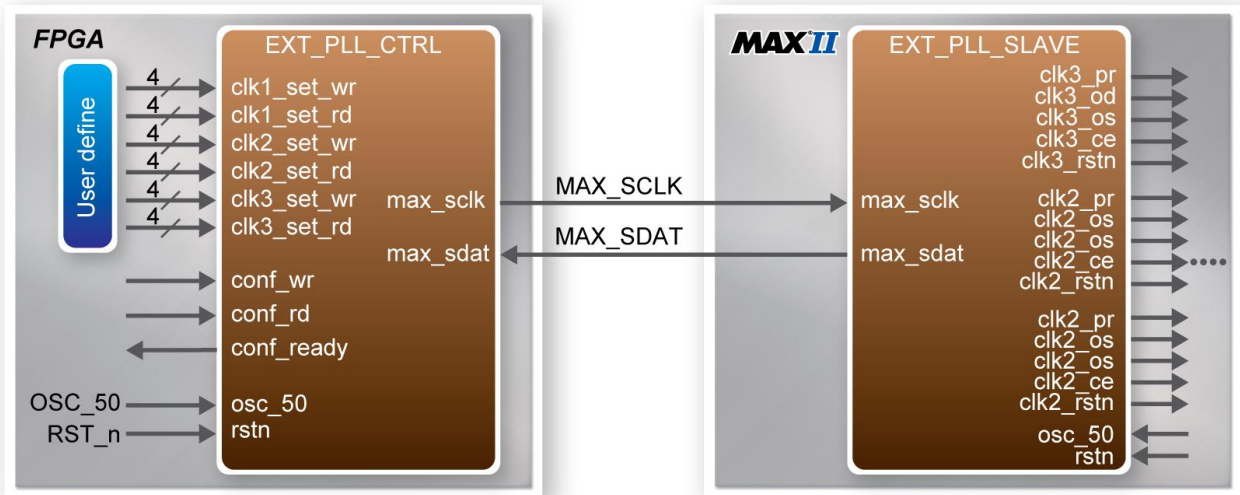

Figure 5–26 EXT_PLL_CTRL Instruction Hardware Ports

Table 5–1 EXT_PLL_CTRL instruction ports

Port Name	Direction	Description
osc_50	input	System Clock (50MHz)
rstn	input	Synchronous Reset (0: Module Reset, 1: Normal)
clk1_set_wr clk2_set_wr clk3_set_wr	input	Setting Output Frequency Value
clk1_set_rd clk2_set_rd clk3_set_rd	output	Read Back Output Frequency Value
conf_wr	input	Start to Transfer Serial Data (postive edge)
conf_rd	input	Start to Read Serial Data (postive edge)
conf_ready	output	Serial Data Transmission is Complete (0: Transmission in Progress, 1: Transmission Complete)
max_sclk	output	Serial Clock to MAX II
max_sdat	inout	Serial Sata to/from MAX II

■ The EXT_PLL_CTRL IP Parameter Setting

Users can refer to the following **Table 5–2** to set the external clock generator for the output frequency.

Table 5–2 EXT_PLL_CTRL Instruction Ports

<i>clk1_set_wr/ clk2_set_wr/ clk3_set_wr</i>	<i>Output Frequency (MHz)</i>	<i>Description</i>
4'b0001	x	Clock Generator Disable
4'b0010	62.5	Setting External Clock Generator
4'b0011	75	
4'b0100	100	
4'b0101	125	
4'b0110	150	
4'b0111	156.23	
4'b1000	187	
4'b1001	200	
4'b1010	250	
4'b1011	312.5	
4'b1100	625	
others	x	

■ The EXT_PLL_CTRL IP Timing Diagram

In this reference design the output frequency is set to 62.5, 75 and 100 MHz with the following timing diagrams illustrated below.

When the EXT_PLL_CTRL IP receives the 'conf_wr' signal, the user needs to define (clk1_set_wr, clk2_set_wr and clk3_set_wr) to set the External Clock Generator. When the ext_pll_ctrl IP receives the 'conf_rd' signal, it will read the value back to clk1_set_rd, clk2_set_rd, and clk3_set_rd.

Write Timing Waveform:

As Button0 (PB1) is pressed the 'conf_wr' signal is on the rising edge, serial data is transferred

immediately with the 'conf_ready' signal in the transmission period starting at falling edge level as shown in **Figure 5–27**. As the transfer is complete, the 'conf_ready' signal returns back to original state at high-level.

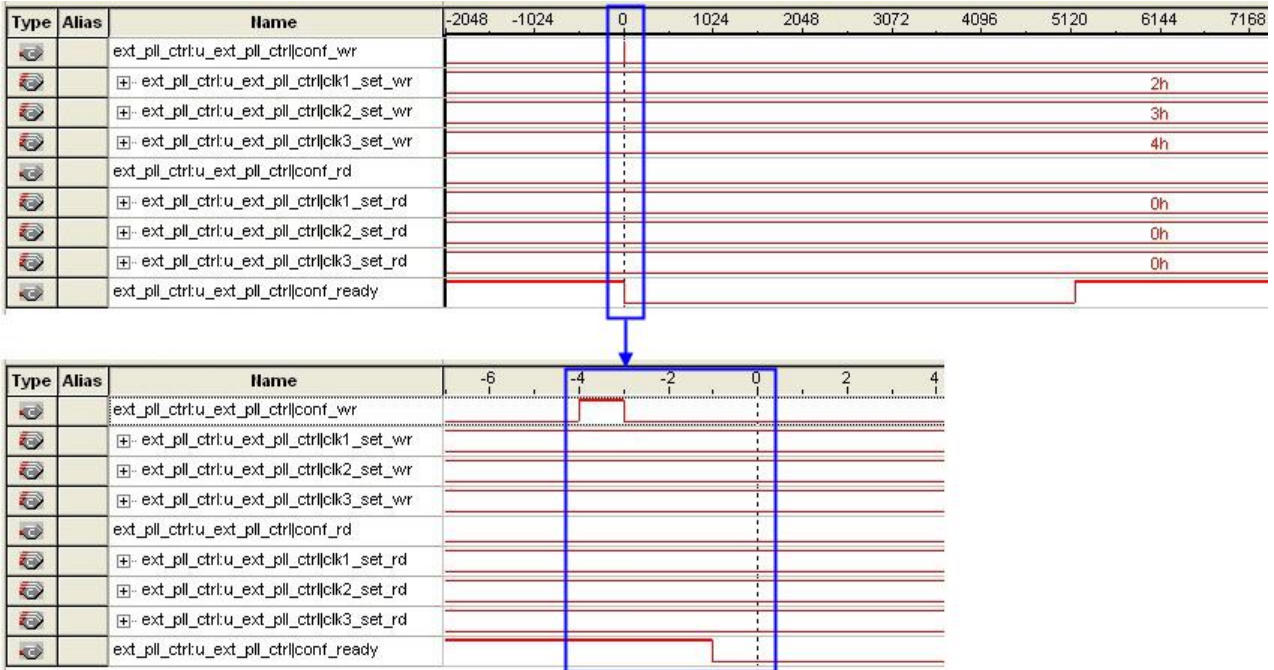

Figure 5–27 Write timing waveform

Read Timing Waveform:

As Button1 (PB2) is pressed the 'conf_rd' signal is on the rising edge, the user settings are read back immediately once the 'conf_ready' signal is on the falling edge as shown in **Figure 5–28**. As the transfer is complete, the 'conf_ready' returns back to original state at high-level.

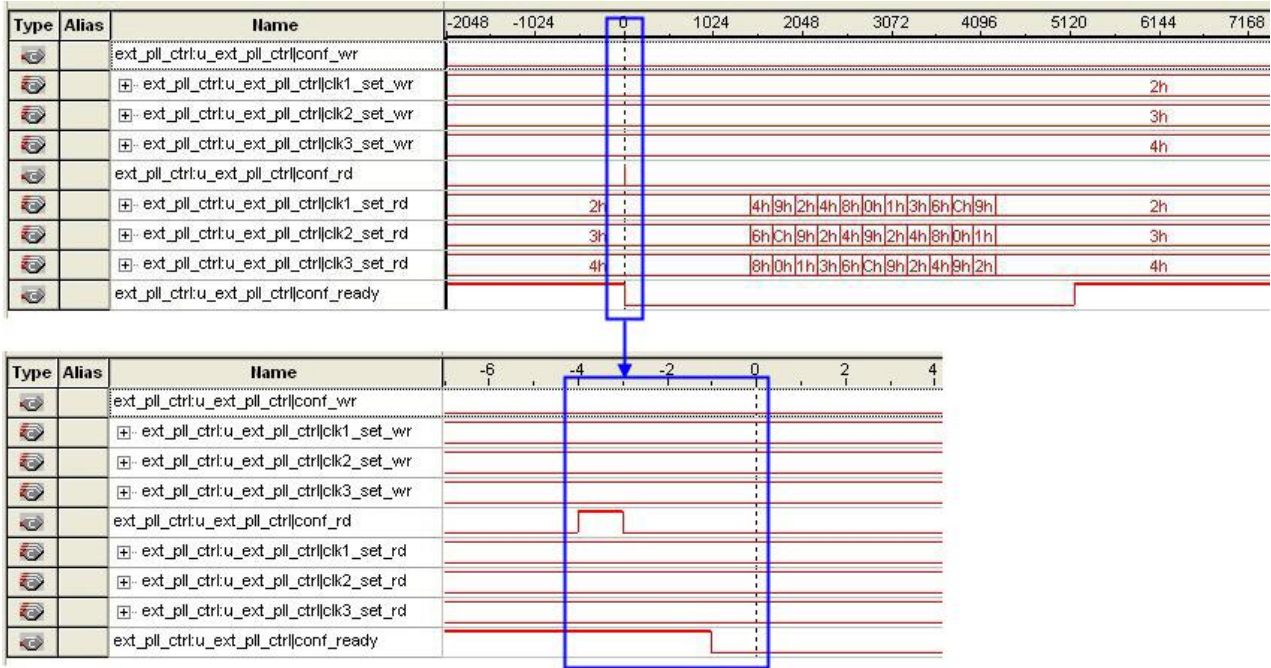

Figure 5–28 Read timing waveform

■ Design Tools

- Quartus II

■ Demonstration Source Code

- Project directory: *DE4_EXT_PLL*
- Bit stream used: *DE4_EXT_PLL.sof*

■ Demonstration Batch File

- Demo Batch File Folder: *DE4_EXT_PLL\demo_batch*

The demo batch file folders include the following files:

- Batch File: *test.bat*
- FPGA Configuration File: *DE4_EXT_PLL.sof*

■ Demonstration Setup

- Make sure Quartus II is installed on your PC.

- Power on the DE4 board.
- Connect USB Blaster to the DE4 board and install USB Blaster driver if necessary.
- Execute the demo batch file “*test.bat*” under the batch file folder, *DE4_EXT_PLL\demo_batch*
- Press Button0 or Button1 for the write and read operations respectively on the EXT_CTRL_PLL demonstration.

5.7 Power Measurement

The Power Measurement demonstration illustrates how to measure the DE4 power consumption based on the built-in power measure circuit. The power measurement is implemented using two multi-channel differential 24-bit Linear Technology LT2418 delta-sigma analog-to-digital converters (ADC) with sense resistors to measure the small voltage drop across the resistors. The ADCs is connected to the FPGA via serial peripheral interface (SPI) bus.

This demonstration uses an embedded NIOS II processor to read the voltage drop value from the ADC through the SPI interface. Based on the voltage drop values and sense resistors, the program can calculate the associated current and power consumption. The relative information is populated on the NIOS-Terminal and is updated every two seconds.

■ System Block Diagram

Figure 5–29 shows the system block diagram of this demonstration which is designed based on SOPC Builder requiring a 50 MHz clock provided by the board. In the SOPC builder, all the components are designed to run on a 50 MHz clock. The NIOS program is run on a on-chip memory. The PIO Controllers are used to implement SPI protocol where the SPI signal is directly toggled by the Nios II.

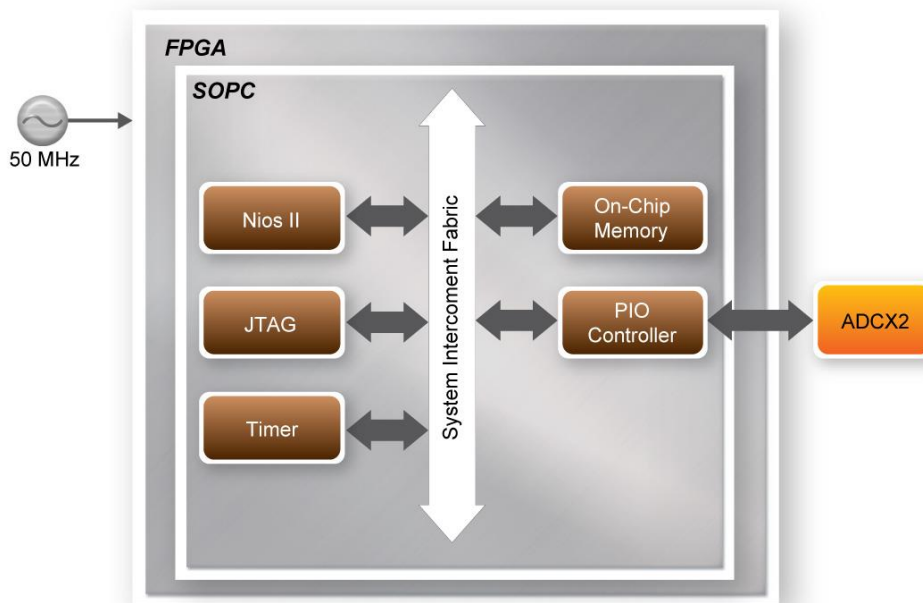

Figure 5–29 Block Diagram of the Power Measurement Demonstration

■ ADC Clock Configuration

In this demonstration the FO pin is connected to GND (FO = 0V), as a result the converter uses its internal oscillator and the digital filter first null is located at 60Hz.

The clock source in SPI transition is configured as External Serial Clock Operation mode by keeping the SCK pin to low at the falling edge of CS pin.

■ ADC SPI Transmission

Figure 5–30 shows the data timing for SPI transmission. The SDI signal is used to serialize data from the FPGA to ADC, and the SDO signal is used to serialize data from ADC to FPGA.

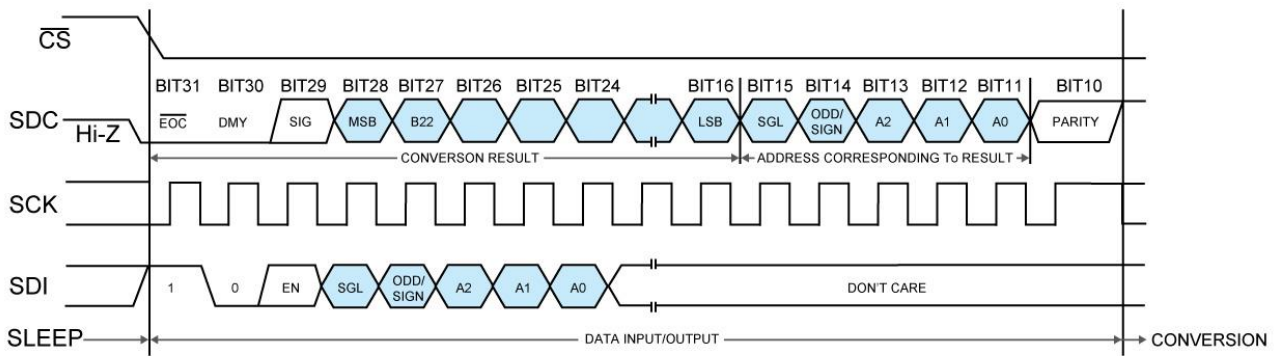

Figure 5–30 SPI input/output data timing

The FPGA can be used to configure the desired conversion channel of the next transmission by serializing an 8-bit configure data to ADC through the SDI signal. In this demonstration, SGL is set to zero to specify differential conversion, and ODD/SIGN is set to zero to specify IN+ as EVEN channel.

The FPGA retrieves the conversion result from the serialized data through the SDO pin. Note the conversion data is for the target channel specified by previous configuration. When ADC is powered on, the default selection used for the first conversion is IN+ = CH0 and IN- = CH1 (Address = 00000).

■ Design Tools

- Quartus II
- NIOS II IDE

■ Demonstration Source Code

- Project directory: *DE4_PowerMeasure*
- Bit stream used: *DE4_PowerMeasure.sof*
- NIOS II Workspace: *DE4_PowerMeasure\Software*

■ Nios II IDE Project Compilation

- Before you attempt to compile the reference design under Nios II IDE, make sure the project is

cleaned first from the 'Project' menu of Nios followed by 'Clean'.

■ Demonstration Batch File

Demo Batch File Folder: DE4_PowerMeasure\Demo_Batch

The demo batch file includes following files:

- Batch File: test.bat, test_bashrc
- FPGA Configure File: DE4_PowerMeasure.sof
- NIOS II Program: DE4_PowerMeasure.elf

■ Demonstration Setup

- Make sure Quartus II and NIOS II are installed on your PC.
- Power on the DE4 board.
- Connect USB Blaster to the DE4 board and install USB Blaster driver if necessary.
- Execute the demo batch file "*test.bat*" under the batch file folder, *DE4_PowerMeasure\demo_batch*.
- After NIOS II program is downloaded and executed successfully, a prompt message will be displayed in nios2-terminal.
- The program will display current power consumption information, as shown in **Figure 5-31**. The information is updated every two seconds.

```

Nios II EDS 9.1
----- DE4 Power Measure -----
-----[tick 0]-----
[Temperature]
  FPCB/Board:46/45
[UCCD_PLL:1FFFF319H_Neg]
  UoIDrop:0.00000(U), Current:0.00000(A), Power:0.00000(W)
[UCCBP9:200906D3H_Pos]
  UoIDrop:0.002204(U), Current:0.734568(A), Power:0.661111(W)
[GPIO_UCCIODP:1FFFFE55H_Neg]
  UoIDrop:0.00000(U), Current:0.00000(A), Power:0.00000(W)
[UCCHIP:20003697H_Pos]
  UoIDrop:0.000052(U), Current:0.017325(A), Power:0.015593(W)
[UCCIP8_34R:1FFFFF19H_Neg]
  UoIDrop:0.00000(U), Current:0.00000(A), Power:0.00000(W)
[HSMA_UCCIO:1FFFFD5AH_Neg]
  UoIDrop:0.00000(U), Current:0.00000(A), Power:0.00000(W)
[UCCIP8_78R:2000005DH_Pos]
  UoIDrop:0.00000(U), Current:0.000079(A), Power:0.000143(W)
[UCCA_PLL:20000ADFH_Pos]
  UoIDrop:0.000010(U), Current:0.003417(A), Power:0.008543(W)
[UCCCL_GXB:20000450H_Pos]
  UoIDrop:0.000004(U), Current:0.001351(A), Power:0.001486(W)
  UoIDrop:0.00000(U), Current:0.00000(A), Power:0.00000(W)
[UCCBP9:20090493H_Pos]
  UoIDrop:0.002202(U), Current:0.733852(A), Power:0.660467(W)
  UoIDrop:0.002202(U), Current:0.733852(A), Power:0.660467(W)
[GPIO_UCCIODP:1FFFFF15H_Neg]
  UoIDrop:0.00000(U), Current:0.00000(A), Power:0.00000(W)
  UoIDrop:0.00000(U), Current:0.00000(A), Power:0.00000(W)
[UCCHIP:20003597H_Pos]
  UoIDrop:0.00000(U), Current:0.00000(A), Power:0.00000(W)
  UoIDrop:0.000051(U), Current:0.017007(A), Power:0.015306(W)
[UCCIP8_34R:1FFFFE18H_Neg]
  UoIDrop:0.00000(U), Current:0.00000(A), Power:0.00000(W)
[Nios II EDS]
  UoIDrop:0.00000(U), Current:0.00000(A), Power:0.00000(W)
[UCCIP8_78R:20000001CH_Pos]
  UoIDrop:0.00000(U), Current:0.00000(A), Power:0.00000(W)
  
```

Figure 5–31 Power consumption information

5.8 Web Server

A web server is implemented based on the socket’s application program interface (API) provided by the NicheStack TCP/IP Stack Nios II Edition running on a MicroC/OS-II RTOS to serve web content from the DE4 development board. Using DHCP protocol, the web server is able to request a valid IP from the Gateway. The server can process basic requests to serve HTML, JPEG, GIF, PNG, JS, CSS, SWF, ICO files from a single zip file stored onto the flash memory on the DE4 board. In addition, it also allows you to control various board elements from the web page which includes controlling the LED lights, 7-segment display, and fan control.

As Part of the Nios II, NicheStack™ TCP/IP Network Stack is a software suite of networking protocols designed to provide an optimal solution for designing network-connected embedded devices with the Nios II processor.

Before you begin to study this demo, we assume that you already have a basic knowledge of PHY and MAC. In this case the PHY we use is Marvell 88E1111 (10/100/1000), and the MAC is Altera’s Triple-speed Ethernet Soft-Core IP.

The following describes the SOPC system which contains a Nios II processor, On-Chip memory, JTAG UART, timer, Triple-Speed Ethernet, Scatter-Gather DMA controller and peripherals which are linked together in the Nios II hardware system to be used when building a project. In the Triple-Speed Ethernet IP Core configuration, the interface is set to SGMII interface as well as using

the internal FIFO shown in [Figure 5–32](#).

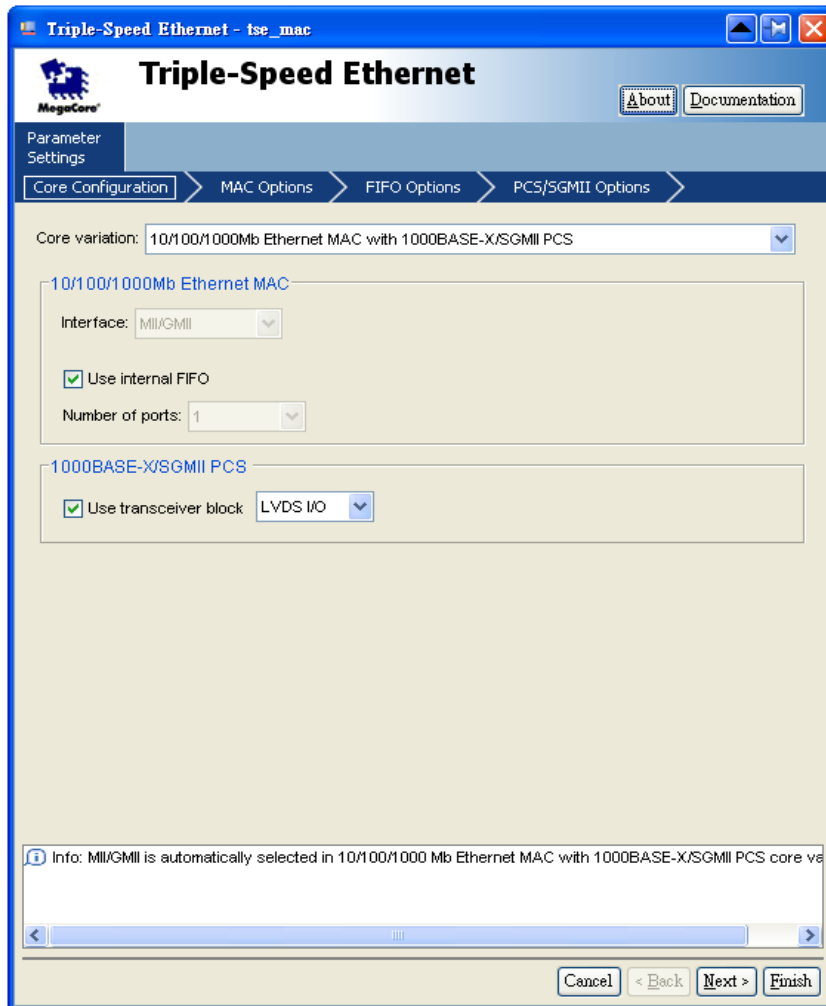

Figure 5–32 SGMII interface MAC Configuration

In the Mac Options section, the Ethernet MAC Options can be equipped selectively according to the users; the MDIO module that controls the PHY Management Module is included associated with the MAC block as shown [Figure 5–33](#). The host Clock divisor is to divide the MAC control register interface clock to produce the MDC clock output on the MDIO interface. The MAC control register interface clock frequency is 100 MHz and the desired MDC clock frequency is 2.5 MHz, so a host clock divisor of 40 should be use.

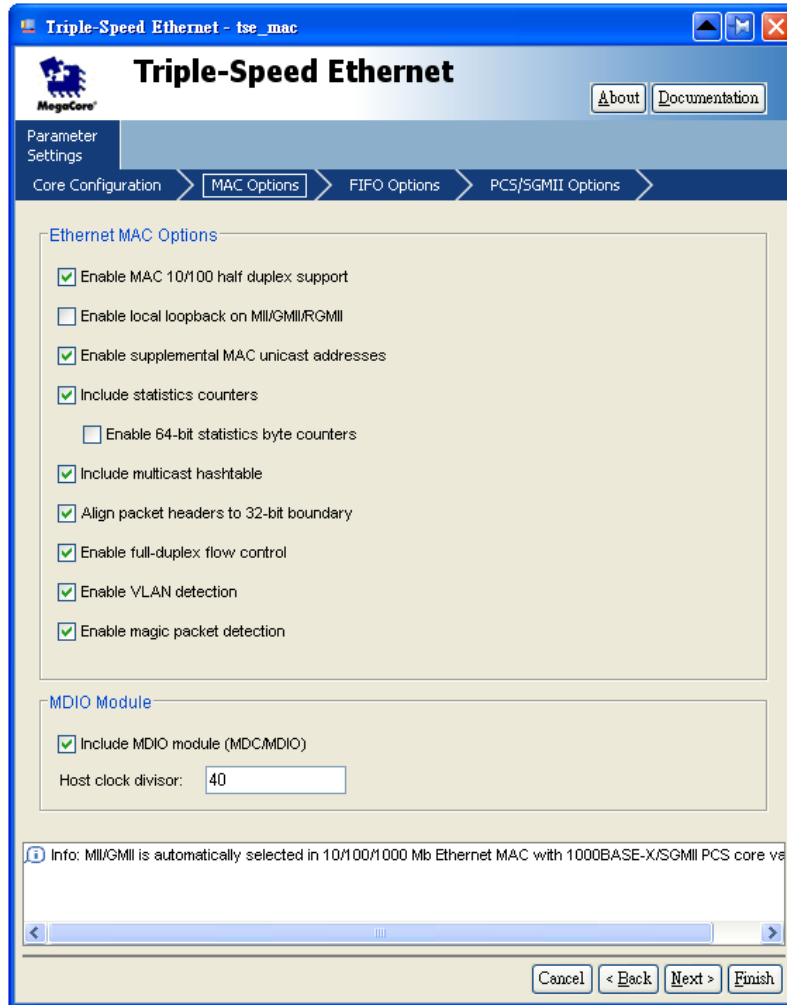

Figure 5–33 MAC Options Configuration

From the PCS/SGMII Options section, enable SGMII bridge logic to add SGMII clock and rate-adaptation logic to the PCS block as shown in [Figure 5–34](#).

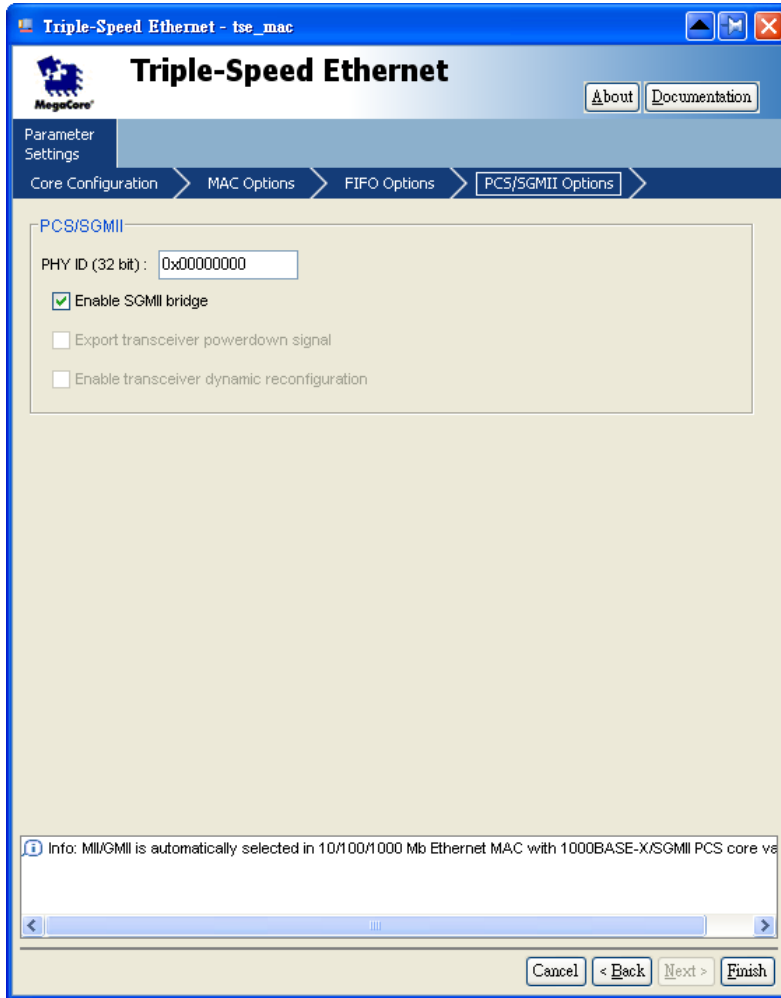

Figure 5–34 PCS/SGMII Options Configuration

Once the Triple-Speed Ethernet IP configuration has been completed and the necessary hardware connections have been made, click on ‘Generate’ to build the interconnect logic automatically as shown in [Figure 5–35](#).

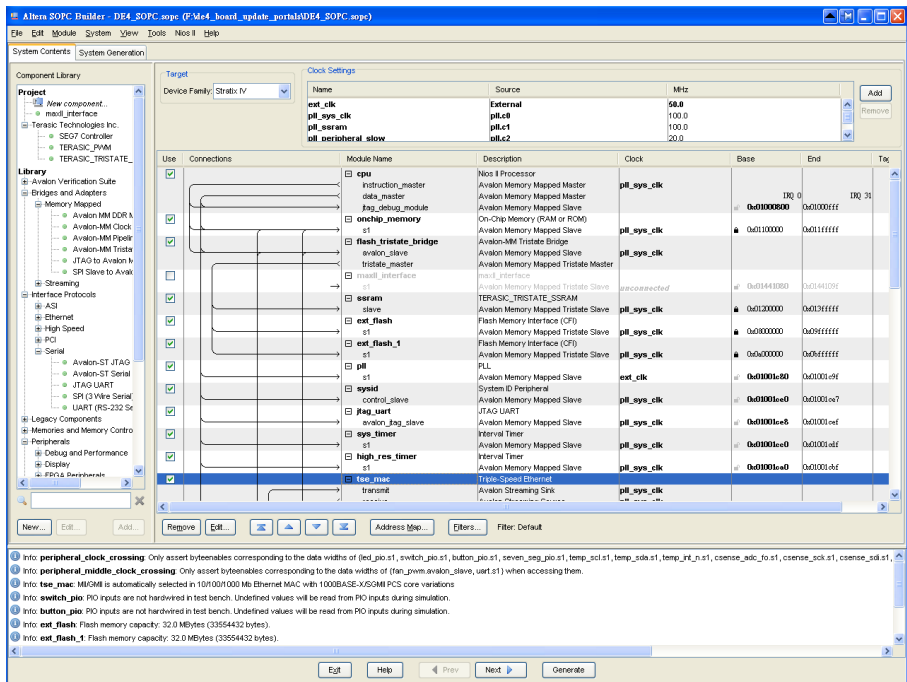

Figure 5-35 SOPC builder

Figure 5–36 shows a block diagram of the PCS function with an embedded PMA

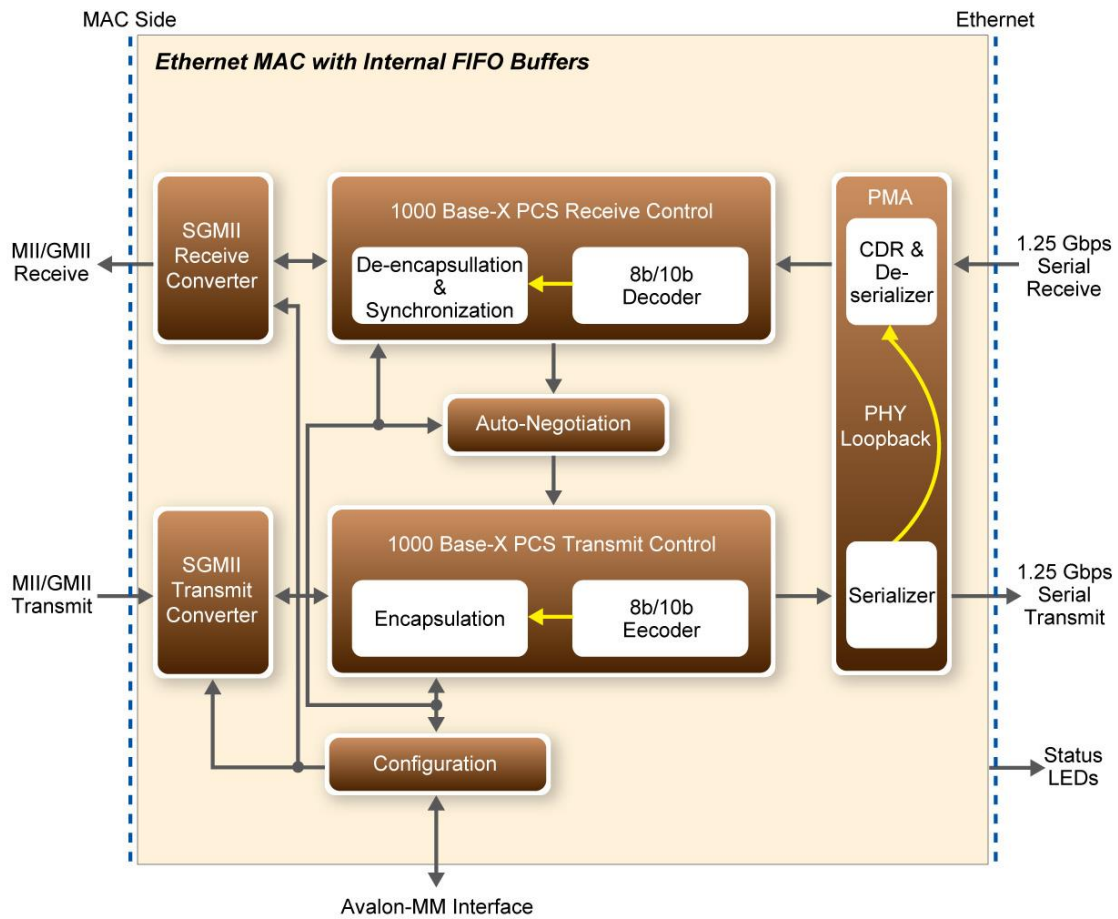

Figure 5–36 1000BASE-X/SGMII PCS with PMA

After the SOPC hardware project being built, develop the SOPC software project, and the basic architecture is shown in Figure 5–37. The top block contains the Nios II processor and the necessary hardware to be implemented into the DE4 host board. The software device drivers contain the necessary device drivers needed for the Ethernet and other hardware components to work. The HAL API block provides the interface for the software device drivers, while the Micro C/OS-II provides communication services to the NicheStack™ and Web Server. The NicheStack™ TCP/IP Stack software block provides networking services to the application block where it contains the tasks for Web Server.

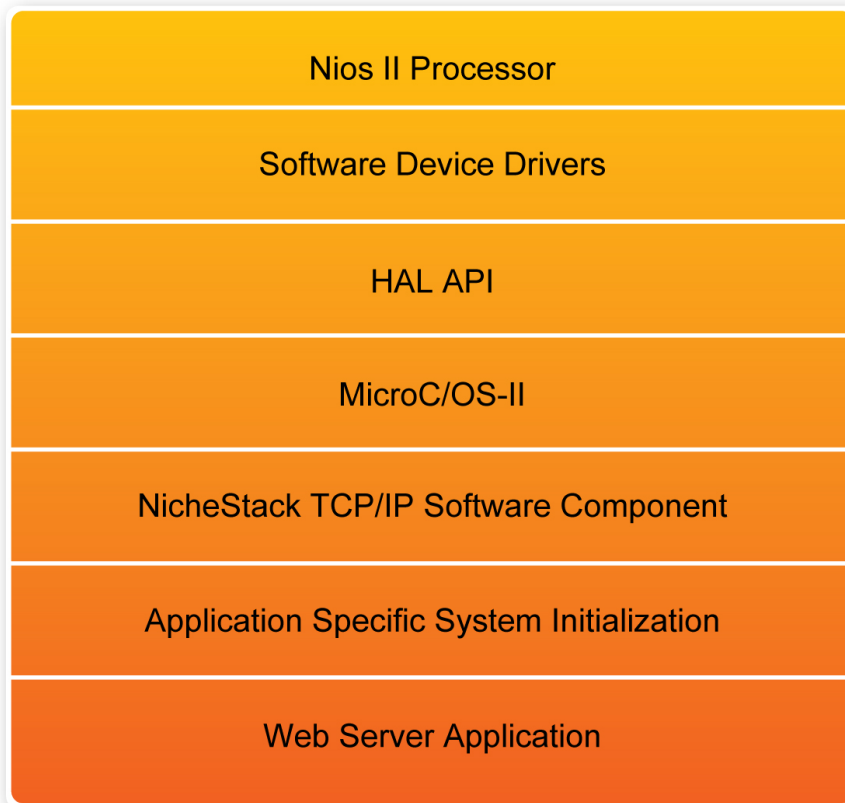

Figure 5–37 Nios II program software architecture

To start with the Web Server program will initiate the MAC and net device then calls the **get_mac_addr()** function to set the MAC addresses for the PHY. Secondly, it initiates the auto-negotiation process to check the link between PHY and gateway device. If the link exists, the PHY and gateway devices will broadcast their transmission parameters, speed and duplex mode. After the auto-negotiation process has finished, it will establish the link. Thirdly, the Web Server program will prepare the transmitting and receiving path for the link. If the path is created successfully, it will call the **get_ip_addr()** function to set up the IP address for the network interface. After the IP address is successfully distributed. The NicheStack™ TCP/IP Stack will start to run for Web Server application.

Figure 5–38 describes this demo setup and connections on the DE4. The Nios II processor is running NicheStack™ on the Micro C/OS-II RTOS.

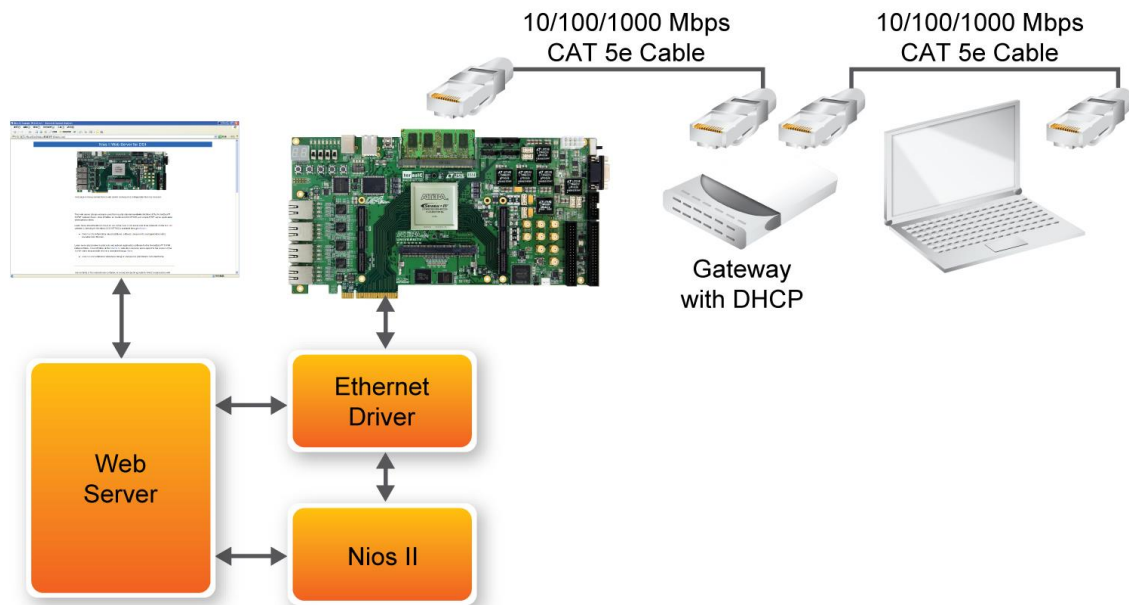

Figure 5–38 System principle diagram

Note: your gateway should support DHCP since the DHCP protocol is used to request a valid IP from the Gateway, and the web server demonstration uses the SGMII interface to access the TCP/IP. You can switch the MAC Interface.

Demonstration Setup, File Locations, and Instructions

The Following steps describe how to setup a Web Server demonstration on the ETHERNET0 in SGMII mode.

- Project directory: DE4_board_update_portal
- Nios II Project workspace: de4_board_update_portal\software\Web_Server
- Bit stream used: DE4_board_update_portal.sof
- Web site content zip file: ro_zipfs.zip
(de4_board_update_portal\software\Web_Server\web_server_syslib\ro_zipfs.zip)
- Launch Quartus II and download the web server demo bit stream into FPGA
- Launch Nios II IDE and open the Nios II Project workspace
- Download the website content zip file into FLASH memory using the Flash Programmer in

NIOS II IDE

- Plug a CAT5 cable into the Ethernet port (J12) on the DE4
- Click on the RUN button in NIOS II IDE window to run this project
- Launch your web browser (Use Internet Explorer 7.0 or later)
- Input the IP into your browser.
- You will see the brand new DE4 web page on your computer illustrated in **Figure 5–39**.

■ Nios II IDE Project Compilation

- Before you attempt to compile the reference design under Nios II IDE, make sure the project is cleaned first from the ‘Project’ menu of Nios followed by ‘Clean’.

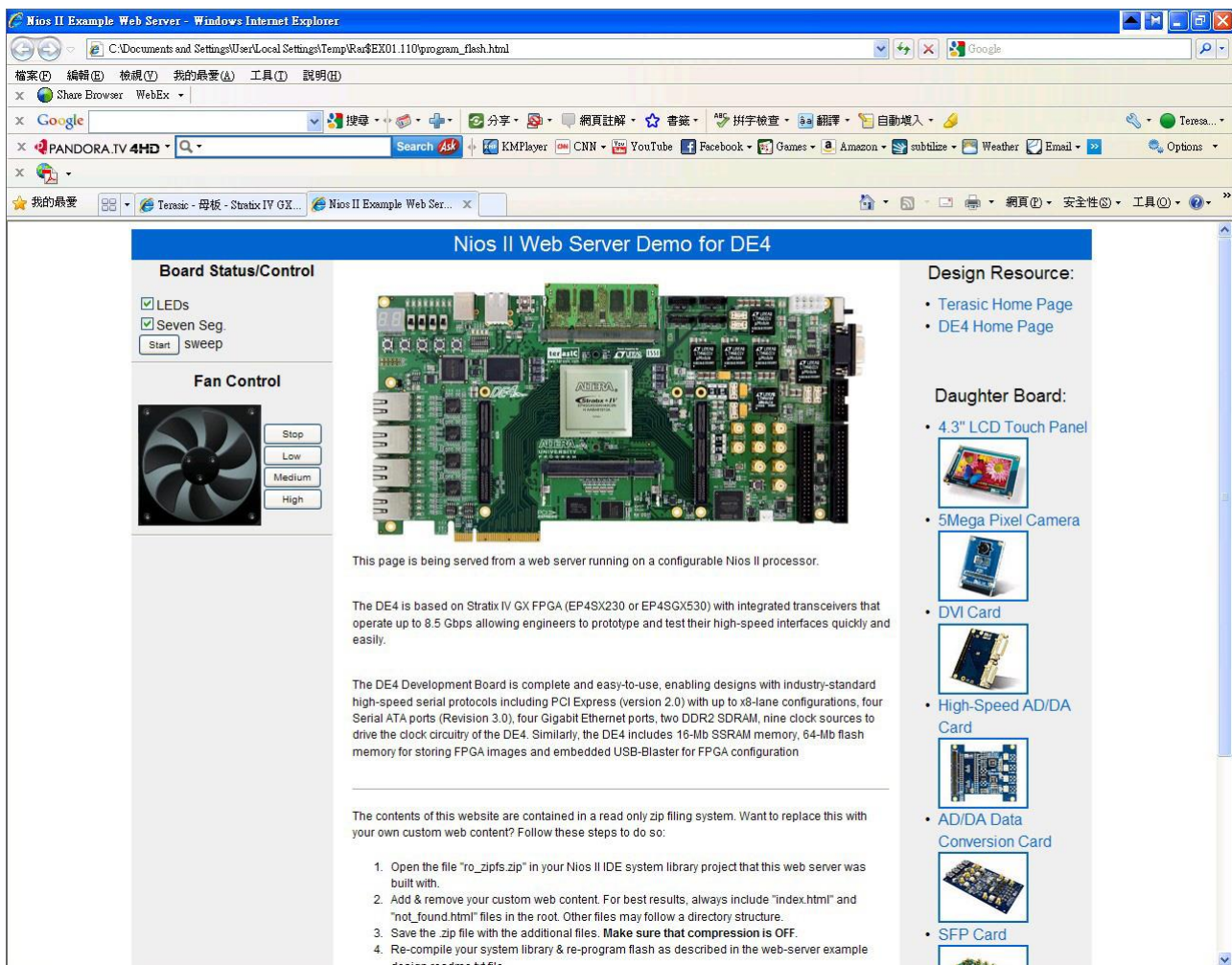

Figure 5–39 DE4 Webserver IE Window

5.9 Serial ATA (SATA)

In this demonstration we illustrate how to use the DE4 board to verify the functionality of SATA host/device ports A and B by testing the transmitter and receiver signals. SATA cables provided in the DE4 kit package are required in this demonstration as it is attached to the SATA host and device ports while an associated design is loaded into the FPGA. The receiver design will synchronize and check for known pattern. If there are errors on the RX channel, the LED [3:0] for that channel will remain off indicating an error condition. If there are zero errors, LED [3:0] are illuminated. By default, the test is run at 6 Gbps.

■ Demonstration Source Code

- Quartus Project directory: *DE4_SATA_LOOPBACK_TEST*
- FPGA Bit stream: *DE4_SATA_LOOPBACK_TEST.sof*

■ Demonstration Setup

- Check that Quartus II and NIOS II are installed on your PC.
- Make sure a SATA cable (provided in the DE4 package) is connected between SATA-host-A and SATA-device-A. Similarly a SATA cable is connected between SATA-host-B and SATA-device-B as shown in **Figure 5-40**.
- Power on the DE4 board.
- Connect USB Blaster to the DE4 board and install USB Blaster driver if necessary.
- Program the DE4 using the *DE4_SATA_LOOPBACK_TEST.sof* through Quartus II programmer.
- Press **RESET** pushbutton[0] of the DE4 board to initiate the verify process
- LED [3:0] will flash once to indicate the loopback test passed.

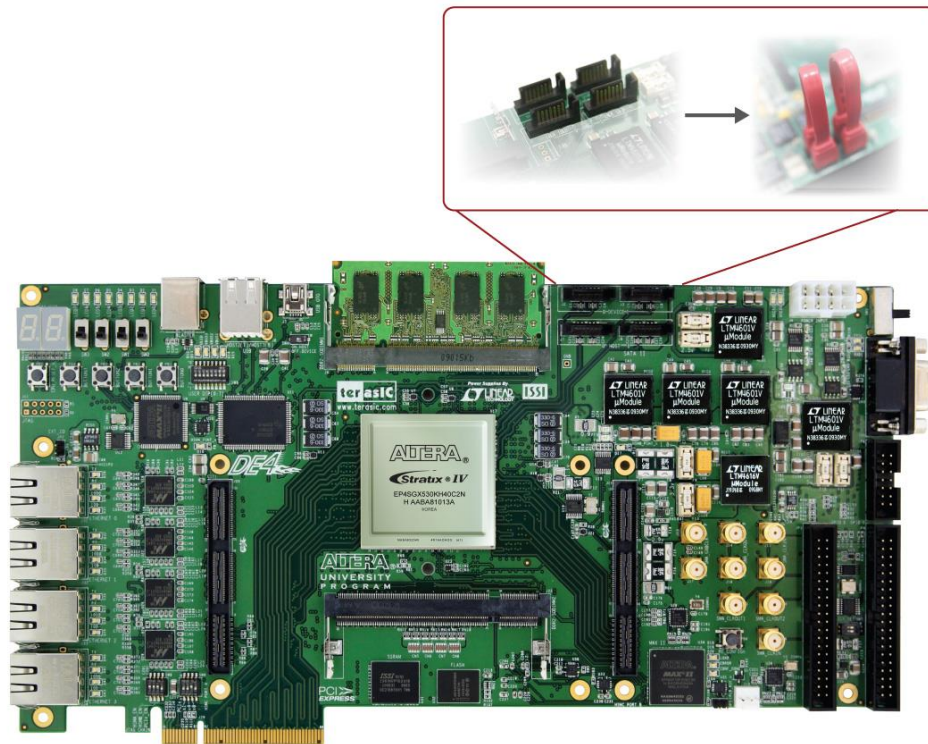

Figure 5-40 Serial ATA loopback design setup

5.10 High-Speed Mezzanine Card (HSMC)

The HSMC loopback demonstration reference design observes the traffic flow with a HSMC loopback adapter which provides a quick way to implement your own design utilizing the transceiver signals situated on the HSMC interface. This design also helps you verify the transceiver signals functionality for ports A and B of the HSMC interface. A total of 8 transceiver pairs on the HSMC port B are tested, while a total of 4 transceiver pairs are tested on HSMC port A.

HSMC Port A Loopback Test:

■ Demonstration Source Code

Quartus Project directory: *DE4_HSMA_LOOPBACK_TEST*

FPGA Bit Stream: *DE4_HSMA_LOOPBACK_TEST.sof*

■ Demonstration Setup

- Check that Quartus II and NIOS II are installed on your PC.
- Insert the HSMC loopback daughter card onto the HSMC port A as shown in **Figure 5–41**.
- Insert the HSMC loopback daughter card onto the HSMC port A.
- Power on the DE4 board.
- Connect USB Blaster to the DE4 board and install USB Blaster driver if necessary.
- Program the DE4 using the *DE4_HSMA_LOOPBACK_TEST.sof* through Quaruts II programmer.
- Press **RESET** pushbutton[0] of the DE4 board to initiate the verify process
- LED [3:0] will flash once indicating the loopback test passed.

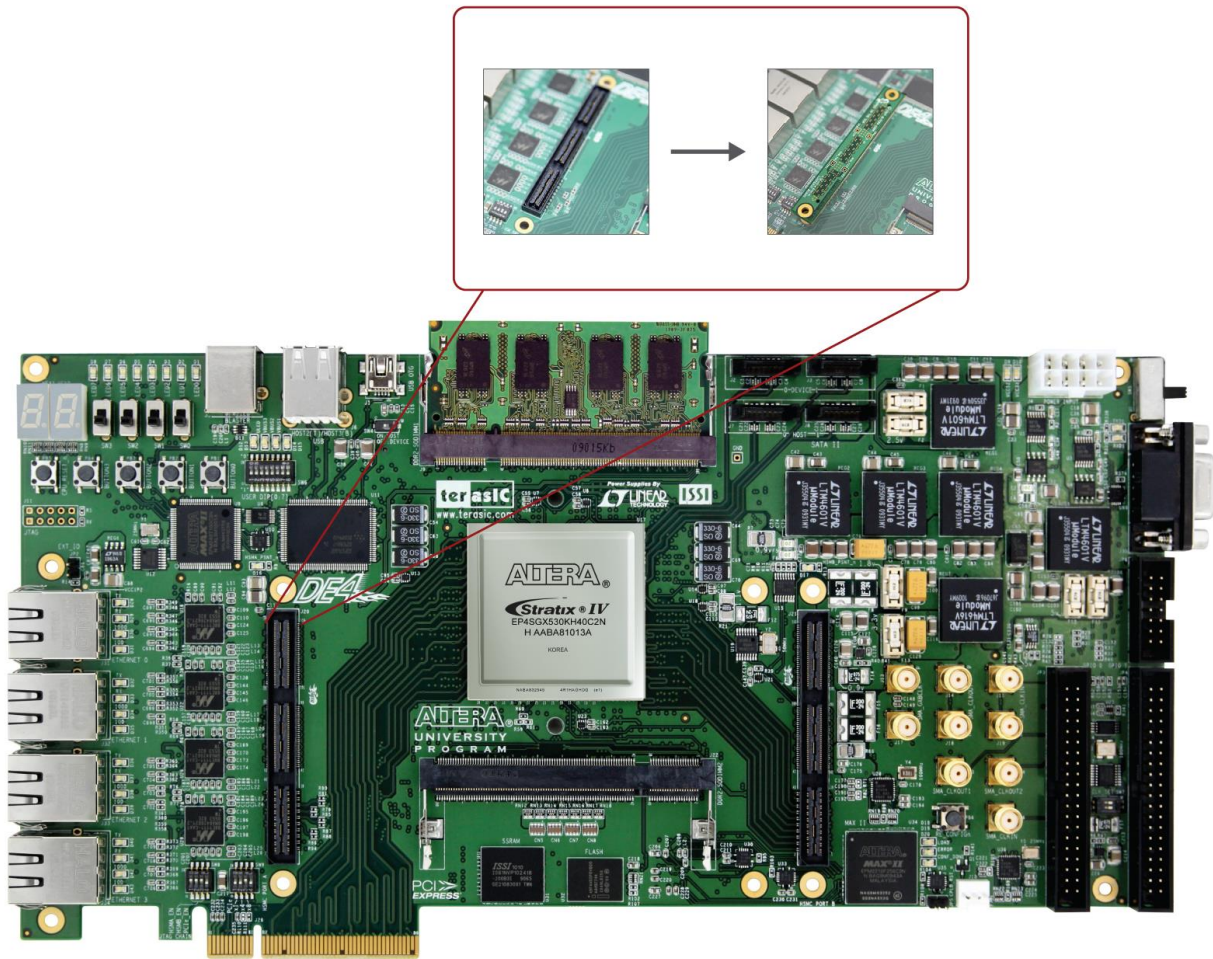

Figure 5–41 HSMC port A loopback design setup

HSMC Port B Loopback Test:

■ Demonstration Source Code

Quartus Project directory: *DE4_HSMB_LOOPBACK_TEST*

FPGA Bit Stream: *DE4_HSMB_LOOPBACK_TEST.sof*

■ Demonstration Setup

- Check that Quartus II and NIOS II are installed on your PC.
- Power on the DE4 board.
- Connect USB Blaster to the DE4 board and install USB Blaster driver if necessary.
- Program the DE4 using the *DE4_HSMB_LOOPBACK_TEST.sof* through Quartus II programmer.
- Press **RESET** pushbutton[0] of the DE4 board to initiate the verify process
- LED [7:0] will flash once to indicate the loopback test passed.

Chapter 6

PCI Express Reference Design

PCI Express is commonly used in consumer, server, and industrial applications, to link motherboard-mounted peripherals. From this demonstration, it will show how the PC and FPGA communicate with each other through the PCI Express interface.

6.1 PCI Express System Infrastructure

The system consists of two primary components, the FPGA hardware implementation and the PC-based application. The FPGA hardware component is developed based on Altera PCIe IP, and the PC-based application is developed under the Jungle driver. **Figure 6–1** shows the system infrastructure. The Terasic PCIe IP license is located in the DE4 System CD under the directory (/DE4_CDROM/License/Terasic_PCIe_TX_RX). This license is required in order to compile the PCIe design projects provided below. In case the license expires, please visit DE4's website (www.de4.terasic.com) to acquire and download a new license.

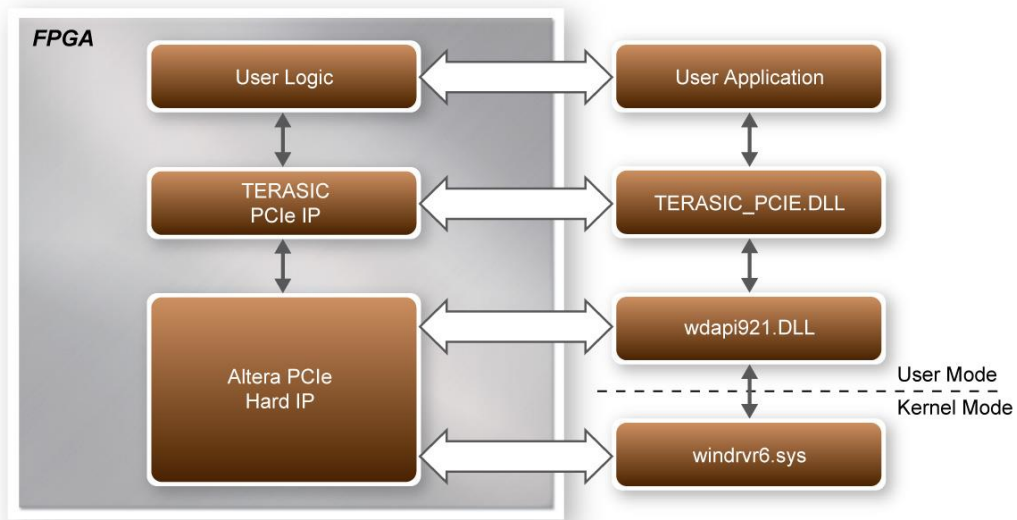

Figure 6-1 PCI Express System Infrastructure

6.2 FPGA PCI Express System Design

The DE4 PCI Express connector is able to allow interconnection to the PCIe motherboard slots. For basic I/O control, a communication is established through the PCI Express bus where it is able to control the LEDs and monitor the status of the DE4 buttons. By implementing an internal RAM and FIFO, the demonstration is capable of direct memory access (DMA) transfers.

■ PCI Express Basic I/O Transaction

Under read operation, the Terasic PCIe IP issues a read signal followed by the address of the data. Once the address is received, a 32-bit data will be sent along with a read valid signal. Under write operation, the PCIe IP issues a write signal accompany with the address to be written. A 32-bit data is written to the corresponding address with a data enable signal of write operation. All the write commands are issued on the same clock cycle. **Table 6-1** lists the associated port names along with the description.

Table 6-1 Single Cycle Transaction Signals of Terasic PCIe IP

Name	Type	Polarity	Description
oCORE_CLK	Output	-	Clock. The reference clock output of PCIe local interface.
oSC_RD_ADDR[11..0]	Output	-	Address bus of read transaction. It is a 32-bit data per address.
iSC_RD_DATA [31..0]	Input	-	Read data bus.

oSC_RD_READ	Output	High	Read signal.
iSC_RD_DVAL	Input	High	Read data valid.
oSC_WR_ADDR[11..0]	Output	-	Address bus of write transaction. It is a 32-bit data per address.
oSC_WR_DATA[31..0]	Output	-	Write data bus.
oSC_WR_WRITE	Output	High	Write signal.

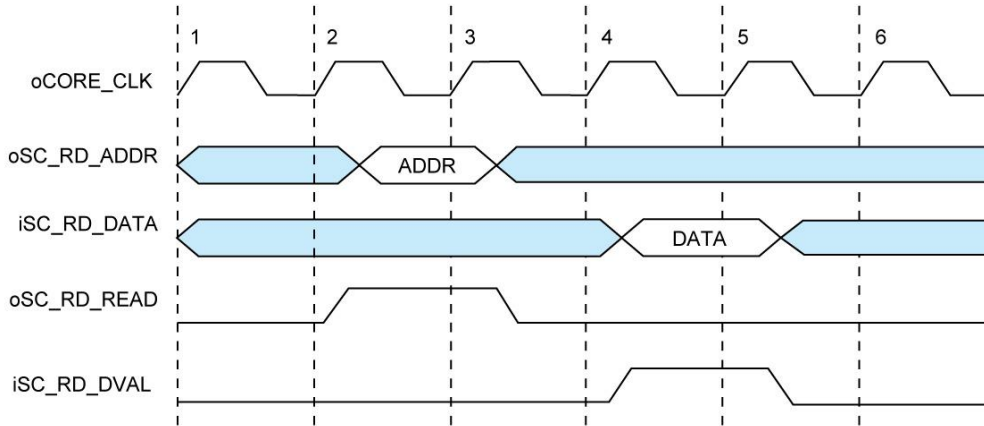

Figure 6–2 Read transaction waveform of the PCIe basic I/O interface

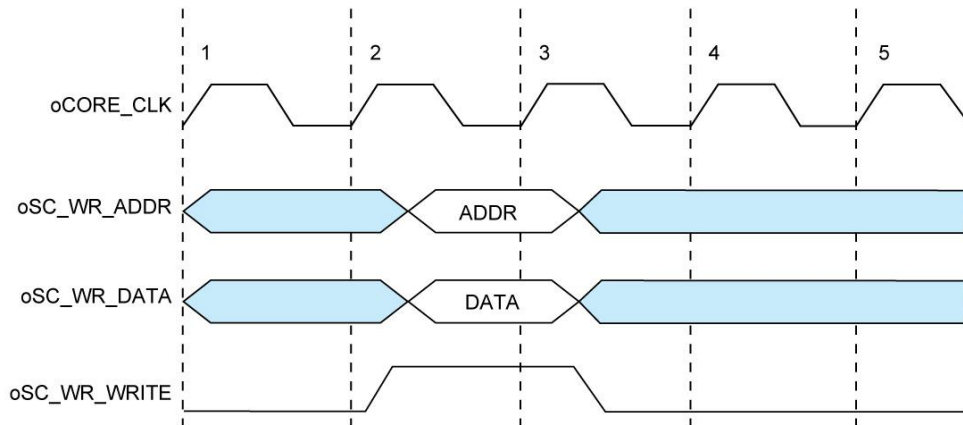

Figure 6–3 Write transaction waveform of the PCIe basic I/O interface

■ PCI Express DMA Transaction

To support greater bandwidth and to improve latency, Terasic PCIe IP provides a high speed DMA channel with two modes of interfaces including memory mapping and FIFO link. The oFIFO_MEM_SEL signal determines the DMA channel used, memory mapping or FIFO link, which is enabled with the assertion of a low and high signal, respectively. The address bus of DMA

indicates the FIFO ID which is defined by user from the PC software API.

Most interfaces experience read latency during the event data is read and processed to the output. To mitigate the overall effects of read latency, minimum delay and timing efficiency is required to enhance the performance of the high-speed DMA transfer. As oDMARD_READ signal is asserted, the read data valid signal oDMARD_RDVALID is inserted high to indicate the data on the iDMARD_DATA data bus is valid to be read after two clock cycles.

Table 6–2 DMA Channel Signals of Terasic PCIe IP

Name	Type	Polarity	Description
oCORE_CLK	Output	-	Clock. The reference clock output of PCIe local interface.
oDMARD_ADDR[31..0]	Output	-	When oFIFO_MEM_SEL is set to low, it is address bus of DMA transfer and the value of address bus is cumulative by PCIe IP and it is 128-bit data per address. When oFIFO_MEM_SEL is set to high, oDMARD_ADDR bus is a FIFO ID that is used to indicate that which FIFO buffer is selected by PC API.
iDMARD_DATA [127..0]	Input	-	Read data bus.
oDMARD_READ	Output	High	Read signal.
oDMARD_RDVALID	Input	High	Read data valid.
oDMAWR_ADDR[31..0]	Output	-	When oFIFO_MEM_SEL is set to low, it is address bus of DMA transfer and the value of address bus is cumulative by PCIe IP and it is 128-bit data per address. When oFIFO_MEM_SEL is set to high, oDMARD_ADDR bus is a FIFO ID that is used to indicate that which FIFO buffer is selected by PC API.
oDMAWR_DATA[127..0]	Output	-	Write data bus.
oDMAWR_WRITE	Output	High	Write signal.
oFIFO_MEM_SEL	Output	-	Indicates that DMA channel is memory mapping interface or FIFO-link interface. When this signal is asserted high, DMA channel FIFO-link interface. When the signal is asserted low, it is memory mapping interface.

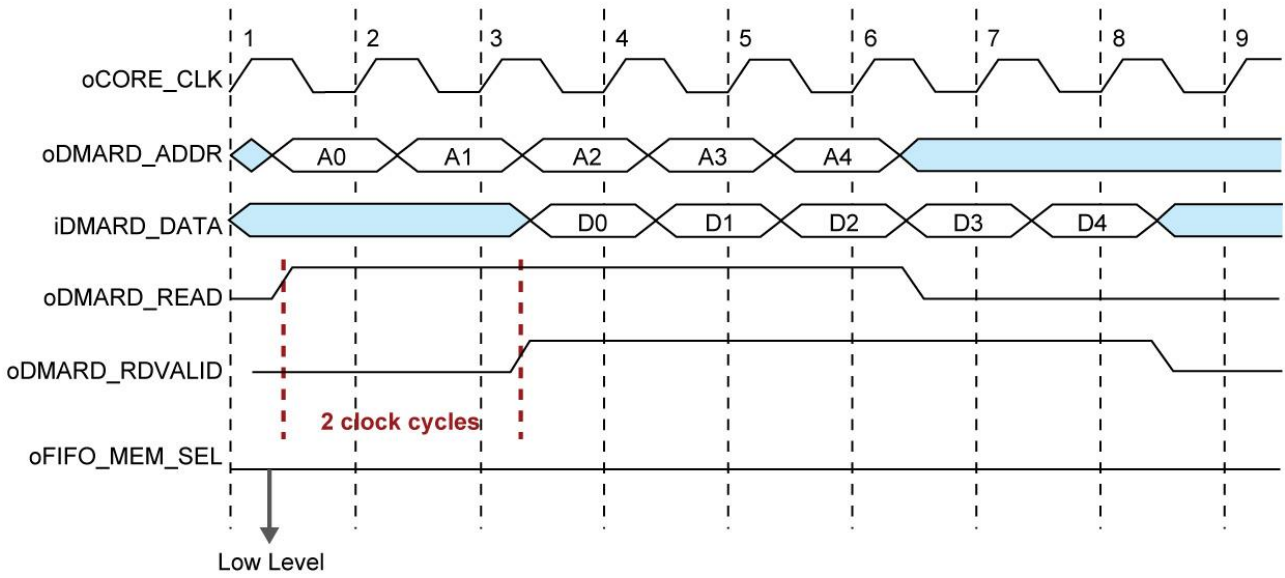

Figure 6–4 Read transaction waveform of the PCIe DMA channel on memory mapping mode

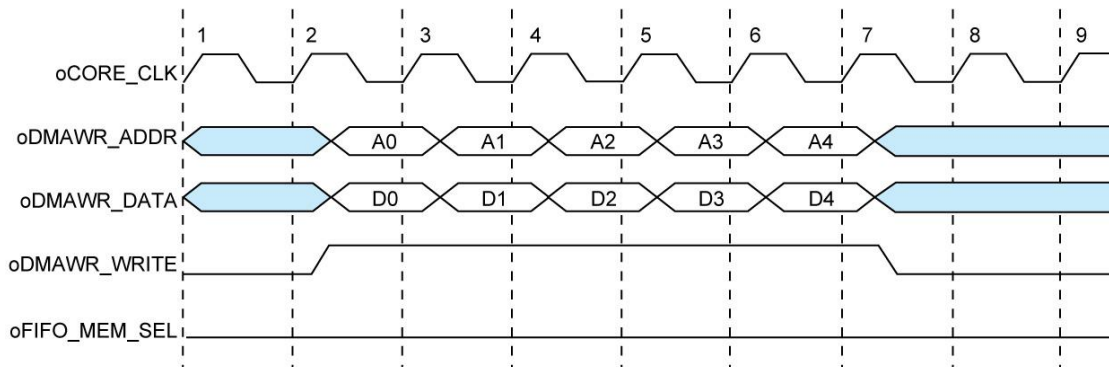

Figure 6–5 Write transaction waveform of the PCIe DMA channel on memory mapping mode

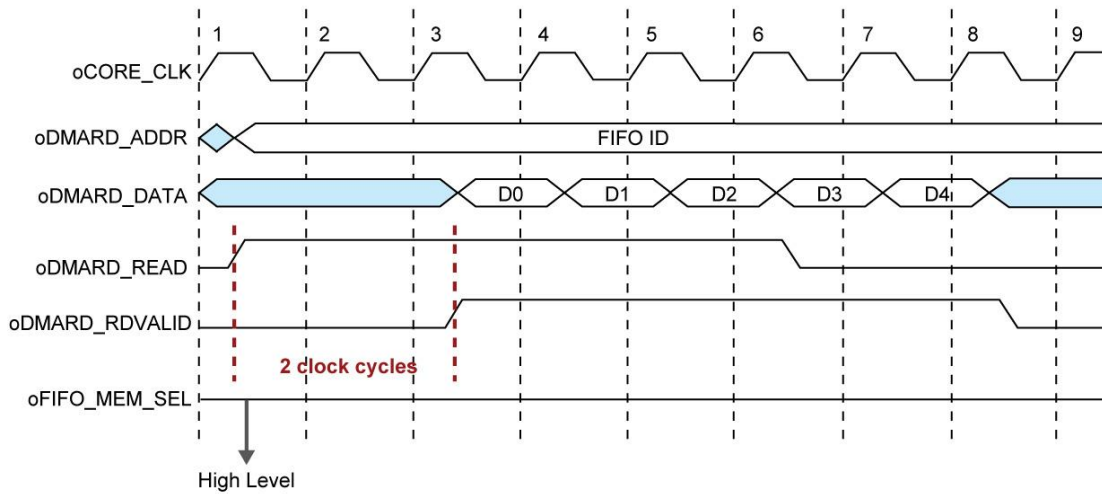

Figure 6–6 Read transaction waveform of the PCIe DMA channel on FIFO-link mode

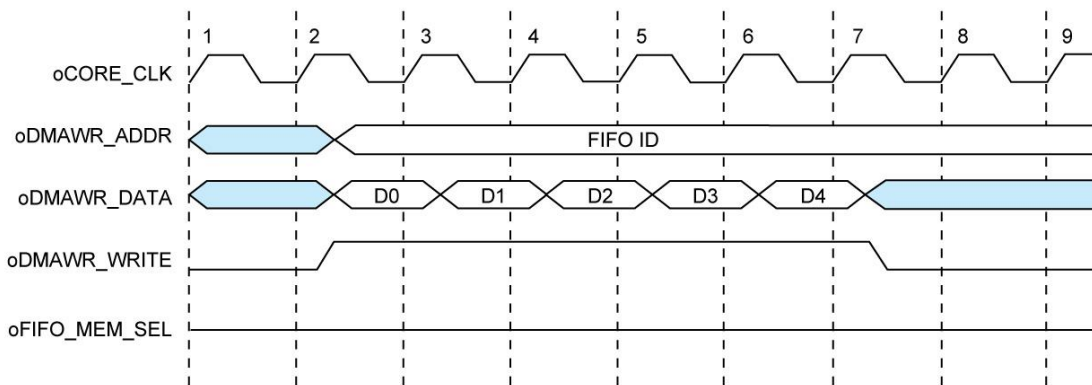

Figure 6–7 Write transaction waveform of the PCIe DMA channel on FIFO-link mode

6.3 PC PCI Express System Design

The DE4 CD contains a PC Windows based SDK to allow users to develop their 32-bits software application on Windows7/WindowXP 32/64-bits. The SDK is located in the “DE4_CDROM \demonstrations\PCIe_SW_KIT” folder which includes:

- PCI Express Driver
- PCI Express Library
- PCI Express Examples

The kernel mode driver requires users to modify the PCIe vendor ID (VID) and device ID (DID) in the driver INF file to match the design in the FPGA where Windows searches for the associated driver.

The PCI Express Library is implemented as a single DLL called Terasic_PCIE.DLL (Terasic_PCIEx64.DLL for 64-bits Windows). With the DLL exported to the software API, users can easily communicate with the FPGA. The library provides the following functions:

- Device Scanning on PCIe Bus
- Basic Data Read and Write
- Data Read and Write by DMA

For high performance data transmission, DMA is required as the read and write operations are specified under the hardware design on the FPGA.

■ PCI Express Software Stack

Figure 6–8 shows the software stack for the PCI Express application software on 32-bits Windows. The PCI Express driver is incorporated in the DLL library called Terasic_PCIE.DLL. Users can develop their application based on this DLL. In 64-bits Windows, Terasic_PCIE.dll is replaced by Terasic_PCIEx64.dll, and wdapi921.dll is replaced by wdapi1100.dll.

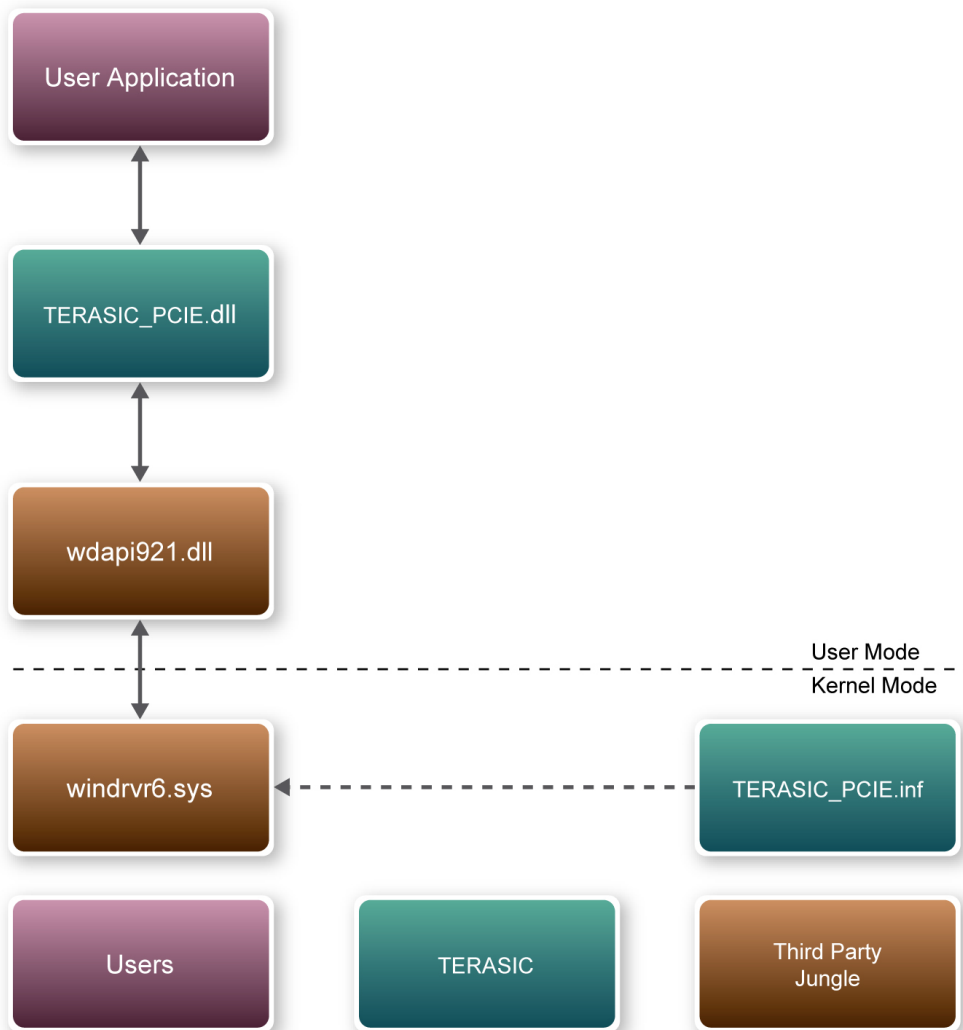

Figure 6–8 PCI Express Software Stack

■ Install PCI Express Driver

To install the PCI Express driver, execute the steps below:

1. From the DE4 system CD locate the PCIe driver folder in the directory `\DE4_CDROM\demonstrations\PCIe_SW_KIT\PCIe_DriverInstall`.
2. Double click the “PCIe_DriverInstall.exe” executable file to launch the installation program shown in **Figure 6–9**.

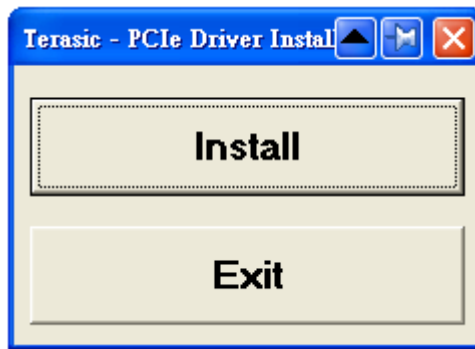

Figure 6–9 PCIe Driver Installation Program

3. Click “Install” to begin installation process.
4. It takes several seconds to install the driver. When installation is complete, the following dialog window will popup shown in **Figure 6–10**. Click “OK” and then “Exit” to close the installation program.

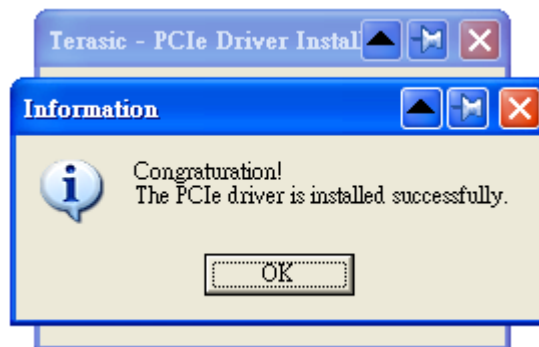

Figure 6–10 PCIe driver installed successfully

5. Once the driver is successfully installed, users can view the device under the device manager window shown in **Figure 6–11**.

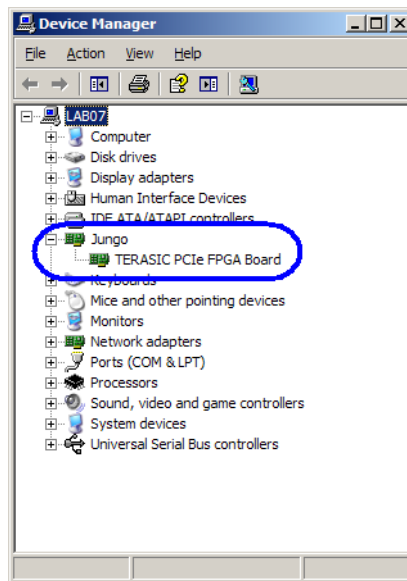

Figure 6–11 Device Manager

■ Create a Software Application

All necessary files to create a PCIe software application are located in the *DE4_CDROM\demonstration\PCIe_SW_KIT\PCIe_Library* which includes the following files:

- Terasic_PCIE.h
- Terasic_PCIE.DLL (for 32-bits Windows)
- Terasic_PCIEx64.DLL (for 64-bits Windows)
- wdapi921.dll (for 32-bits Windows)
- wdapi1100.dll (for 64-bits Windows)

Below lists the procedures to use the SDK files in users' C/C++ project :

- Create users' C/C++ project.
- Include Terasic_PCIE.h in the 32-bits C/C++ project.
- Copy Terasic_PCIE.DLL(Terasic_PCIEx64.DLL for 64-bits Windows) to the folder where the project.exe is located.
- Dynamically load Terasic_PCIE.DLL(Terasic_PCIEx64 for 64-bits Windows) in C/C++ project. To load the DLL, please refer to two examples below.
- Call the SDK API to implement desired application.

■ Terasic_PCIE.DLL/Terasic_PCIEx64.DLL Software API

Using the Terasic_PCIE.DLL/TERASIC_PCIEx64.DLL software API, users can easily communicate with the FPGA through the PCIe bus. The API details are described below :

PCIE_ScanCard

<p>Function:</p> <p>Lists the PCIe cards which matches the given vendor ID and device ID. Set Both ID to zero to lists the entire PCIe card.</p>
<p>Prototype:</p> <pre> BOOL PCIE_ScanCard(WORD wVendorID, WORD wDeviceID, DWORD *pdwDeviceNum, PCIE_CONFIG szConfigList[]); </pre>
<p>Parameters:</p> <p>wVendorID: Specify the desired vendor ID. A zero value means to ignore the vendor ID.</p> <p>wDeviceID: Specify the desired device ID. A zero value means to ignore the produce ID.</p> <p>pdwDeviceNum: A buffer to retrieve the number of PCIe card which is matched by the desired vendor ID and product ID.</p> <p>szConfigList: A buffer to retrieve the device information of PCIe Card found which is matched by the desired vendor ID and device ID.</p>
<p>Return Value:</p> <p>Return TRUE if PCIe cards are successfully enumeated; otherwise, FALSE is return.</p>

PCIE_Open

<p>Function:</p> <p>Open a specified PCIe card with vendor ID, device ID, and matched card index.</p>
<p>Prototype:</p>

```
PCIE_HANDLE PCIE_Open(
    WORD wVendorID,
    WORD wDeviceID,
    WORD wCardIndex);
```

Parameters:

wVendorID:

Specify the desired vendor ID. A zero value means to ignore the vendor ID.

wDeviceID:

Specify the desired device ID. A zero value means to ignore the device ID.

wCardIndex:

Specify the matched card index, a zero based index, based on the matched vendor ID and device ID.

Return Value:

Return a handle to presents specified PCIe card. A positive value is return if the PCIe card is opened successfully. A value zero means failed to connect the target PCIe card.

This handle value is used as a parameter for other functions, e.g. PCIE_Read32.

Users need to call PCIE_Close to release handle once the handle is no more used.

PCIE_Close

Function:

Close a handle associated to the PCIe card.

Prototype:

```
void PCIE_Close(
    PCIE_HANDLE hPCIE);
```

Parameters:

hPCIE:

A PCIe handle return by PCIE_Open function.

Return Value:

None.

PCIE_Read32

Function:

Read a 32-bits data from the FPGA board.

Prototype:

```
bool PCIE_Read32(
```



```

PCIE_HANDLE hPCIE,
PCIE_BAR PcieBar,
PCIE_ADDRESS PcieAddress,
DWORD * pdwData);

```

Parameters:

hPCIE:
A PCIe handle return by PCIE_Open function.

PcieBar:
Specify the target BAR.

PcieAddress:
Specify the target address in FPGA.

pdwData:
A buffer to retrieve the 32-bits data.

Return Value:

Return TRUE if read data is successful; otherwise FALSE is returned.

PCIE_Write32

Function:

Write a 32-bits data to the FPGA Board.

Prototype:

```

bool PCIE_Write32(
    PCIE_HANDLE hPCIE,
    PCIE_BAR PcieBar,
    PCIE_ADDRESS PcieAddress,
    DWORD dwData);

```

Parameters:

hPCIE:
A PCIe handle return by PCIE_Open function.

PcieBar:
Specify the target BAR.

PcieAddress:
Specify the target address in FPGA.

dwData:
Specify a 32-bits data which will be written to FPGA board.

Return Value:

Return TRUE if write data is successful; otherwise FALSE is returned.

PCIE_DmaRead

Function:

Read data from the memory-mapped memory of FPGA board in DMA function.

Prototype:

```
bool PCIE_DmaRead(
    PCIE_HANDLE hPCIE,
    PCIE_LOCAL_ADDRESS LocalAddress,
    void *pBuffer,
    DWORD dwBufSize
);
```

Parameters:

hPCIE:

A PCIe handle return by PCIE_Open function.

LocalAddress:

Specify the target memory-mapped address in FPGA.

pBuffer:

A pointer to a memory buffer to retrieved the data from FPGA. The size of buffer should be equal or larger the dwBufSize.

dwBufSize:

Specify the byte number of data retrieved from FPGA.

Return Value:

Return TRUE if read data is successful; otherwise FALSE is returned.

PCIE_DmaWrite

Function:

Write data to the memory-mapped memory of FPGA board in DMA function.

Prototype:

```
bool PCIE_DmaWrite(
    PCIE_HANDLE hPCIE,
    PCIE_LOCAL_ADDRESS LocalAddress,
    void *pData,
```

DWORD dwDataSize);
Parameters: hPCIE: A PCIe handle return by PCIE_Open function. LocalAddress: Specify the target memory mapped address in FPGA. pData: A pointer to a memory buffer to store the data which will be written to FPGA. dwDataSize: Specify the byte number of data which will be written to FPGA.
Return Value: Return TRUE if write data is successful; otherwise FALSE is returned.

PCIE_DmaFifoRead

Function: Read data from the memory fifo of FPGA board in DMA function.
Prototype: <pre> bool PCIE_DmaFifoRead(PCIE_HANDLE hPCIE, PCIE_LOCAL_FIFO_ID LocalFifoId, void *pBuffer, DWORD dwBufSize); </pre>
Parameters: hPCIE: A PCIe handle return by PCIE_Open function. LocalFifoId: Specify the target memory fifo ID in FPGA. pBuffer: A pointer to a memory buffer to retrieved the data from FPGA. The size of buffer should be equal or larger the dwBufSize. dwBufSize:

Specify the byte number of data retrieved from FPGA.

Return Value:

Return TRUE if read data is successful; otherwise FALSE is returned.

PCIE_DmaFifoWrite

Function:

Write data to the memory fifo of FPGA board in DMA function.

Prototype:

```
bool PCIE_DmaFifoWrite(
    PCIE_HANDLE hPCIE,
    PCIE_LOCAL_FIFO_ID LocalFifoId,
    void *pData,
    DWORD dwDataSize
);
```

Parameters:

hPCIE:

A PCIe handle return by PCIE_Open function.

LocalFifoId:

Specify the target memory fifo ID in FPGA.

pData:

A pointer to a memory buffer to store the data which will be written to FPGA.

dwDataSize:

Specify the byte number of data which will be written to FPGA.

Return Value:

Return TRUE if write data is successful; otherwise FALSE is returned.

6.4 Fundamental Communication

The application reference design shows how to implement fundamental control and data transfer. In the design, basic I/O is used to control the BUTTON and LED on the DE4. High-speed data transfer is performed by DMA. Both Memory-Mapped and FIFO memory types are demonstrated in the reference design. The demonstration also lists the associated PCIe cards.

■ Demonstration Files Location

The demo file is located in the folder: *PCIE_Fundamental\Demo_batch*

The folder includes following files:

- PC Application Software: *PCIE_Fundamental_Demo.exe*
- FPGA Configuration File: *DE4_Fundamental.sof*
- PCIe Library : *TERASIC_PCIE.DLL* and *wapi921.dll* (*TERASIC_PCIEx64.DLL* and *wapi1100.dll* for 64-bits Widnows)
- Demo Batch File : *test.bat*

■ Demonstration Setup

- Install DE4 on your PC.
- Download the *DE4_Fundamental.sof* into the DE4 using Quartus II Programmer.
- Restart Windows
- Install PCIe driver if necessary. The driver is located in the folder *DE4_CDRROM\demonstration\PCie_SW_KIT\PCie_DriverInstall*.
- Launch the demo program *PCIE_Fundamental_Demo.exe* shown in **Figure 6–12**.

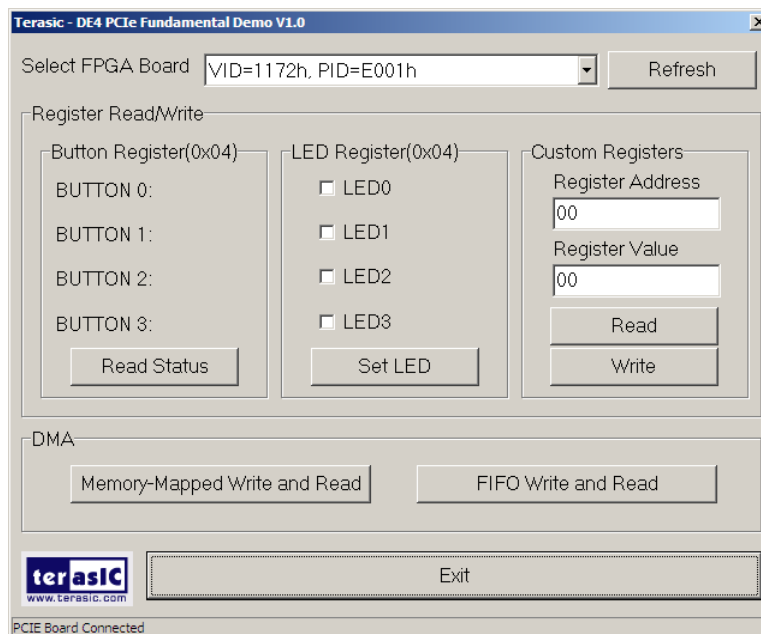

Figure 6–12

- Make sure the ‘Selected FPGA Board’ appear as the target board “VID=1172, DID=E001”.

- Press Button0-3 in DE4 and click the Read Status in this application software.
- Check/Uncheck the LED0-3 in this application software, then click ‘Set LED’. The LED in the DE4 will change.
- Click ‘Memory-Mapped Write and Read’ to test memory –mapped DMA. A report dialog will appear when the DMA process is completed.
- Click ‘FIFO Write and Read’ to test FIFO DMA. A report dialog box will appear when the DMA process is completed.
- The ‘Custom Registers Group’ is used to test custom design register on the FPGA side. Users can use this function to verify custom register design.

■ **Demonstration Setup**

- Quartus II 9.1 SP2
- Borland C++ Builder

■ **Demonstration Source Code Location**

- Quartus Project: PCIE_Fundamental
- Borland C++ Project: PCIE_Fundamental\pc

■ **FPGA Application Design**

The PCI Express demonstration uses the basic I/O interface and DMA channel on the Terasic PCIe IP to control I/O (Button/LED) and access two internal memories (RAM/FIFO) through the MUX block.

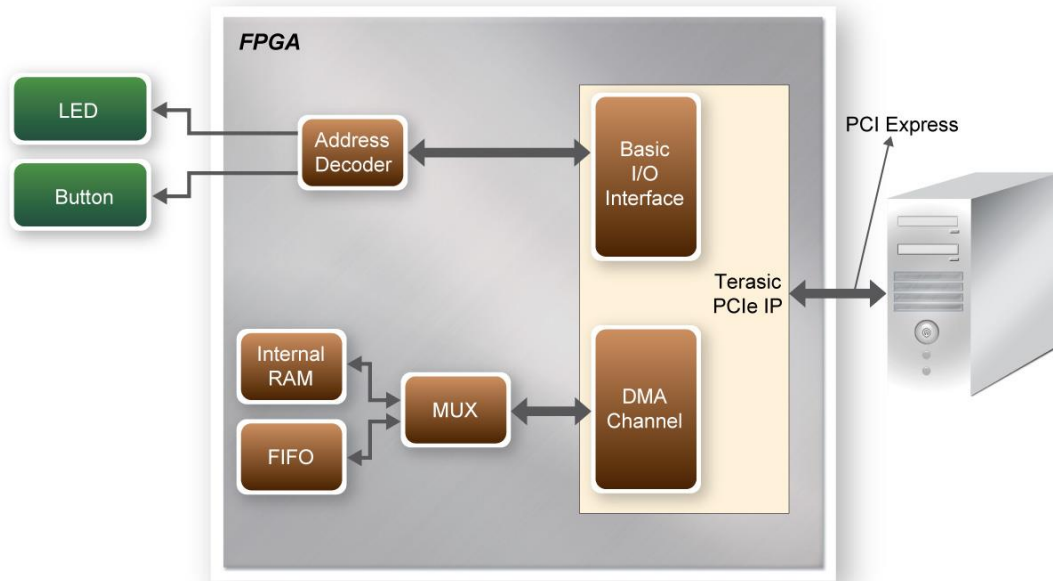

Figure 6–13 Hardware block diagram of the PCIe reference design

■ PC Application Design

The application shows how to call the Terasic PCIe DLL (Terasic PCIe 64-bit DLL under 64-bit Windows) exported API. To enumerate all PCIe cards in system call, the software design defines some constant based on FPGA design shown below:

```
#define PCIE_VID          0x1172
#define PCIE_DID          0xE001

#define DEMO_PCIE_USER_BAR  PCIE_BAR1
#define DEMO_PCIE_IO_ADDR  0x04
#define DEMO_PCIE_FIFO_ID  0x00
```

The vendor ID is defined as 0x1172 and the device ID is defined as 0xE001. The BUTTON/LED register address is 0x04 based on PCIE_BAR1.

A C++ class **PCIE** is designed to encapsulate the DLL dynamic loading for Terasic PCIe DLL (loading Terasic PCIe 64-bit DLL under 64-bit Windows). A PCIE instance is created with the name **m_hPCIE**. To enumerate all PCIe cards in system, call the function

```
m_hPCIE.ScanCard(wVendorID, wDeviceID, &dwDeviceNum, m_szPcieInfo);
```

where wVendorID and wDeviceID are zeros. The return value dwDeviceNum represents the number of PCIe cards found in the system. The m_szPcieInfo array contains the detail information for each PCIe card.

To connect the selected PCIe card, the functions are called:

```
int nSel = ComboBoxBoard->ItemIndex;
WORD VID = m_szPcieInfo[nSel].VendorID;
WORD DID = m_szPcieInfo[nSel].DeviceID;
bSuccess = m_hPCIE.Open(VID,DID,0); //0: first matched board
```

where nSel is selected index in the 'Selected FPGA Board' poll-down menu. Based on the return m_szPcieInfo, we can find the associated PID and DID which can use to specify the target PCIe card.

To read the BUTTON status, the function is called:

```
m_hPCIE.Read32(DEMO_PCIE_USER_BAR, DEMO_PCIE_IO_ADDR, &dwData);
```

To set LED status, the function is called:

```
m_hPCIE.Write32(DEMO_PCIE_USER_BAR, DEMO_PCIE_IO_ADDR, dwData);
```

To write and read memory-mapped memory, call the functions:

```
// write
bSuccess = m_hPCIE.DmaWrite(LocalAddr, pWrite, nTestSize);
if (bSuccess){
    // read
    bSuccess = m_hPCIE.DmaRead(LocalAddr, pRead, nTestSize);
}
```

To write and read FIFO memory, call the functions:

```
// write
bSuccess = m_hPCIE.DmaFifoWrite(FifoID, pWrite, nTestSize);
if (bSuccess){
    // read
    bSuccess = m_hPCIE.DmaFifoRead(FifoID, pRead, nTestSize);
}
```

6.5 Example 2: Image Process Application

This example shows how to utilize computing power of the FPGA for image processing. The application demonstrates the ‘invert’ image processing by utilizing the FPGA. The PC and FPGA source code of the application layer are all available in the DE4 system CD, allowing users to easily extend the image process function based on this fundamental reference design.

In the demonstration, a memory-mapped memory is designed in the FPGA to work as an image frame buffer. The memory size is 320x240x3 bytes with start address 0x00. The raw image is downloaded to and uploaded from FPGA by DMA. The image process command and status is controlled by a register which can be accessed from the PC by basic IO control. The register address is 0x10 under PCIE BAR1. Writing any value into this register will start the image process. The status of the image process is reported by a read to this register. The PCIe vendor ID and device ID is 0x1172 and 0xE001, respectively. The block diagram of FPGA PCIe design is shown in **Figure 6–14**.

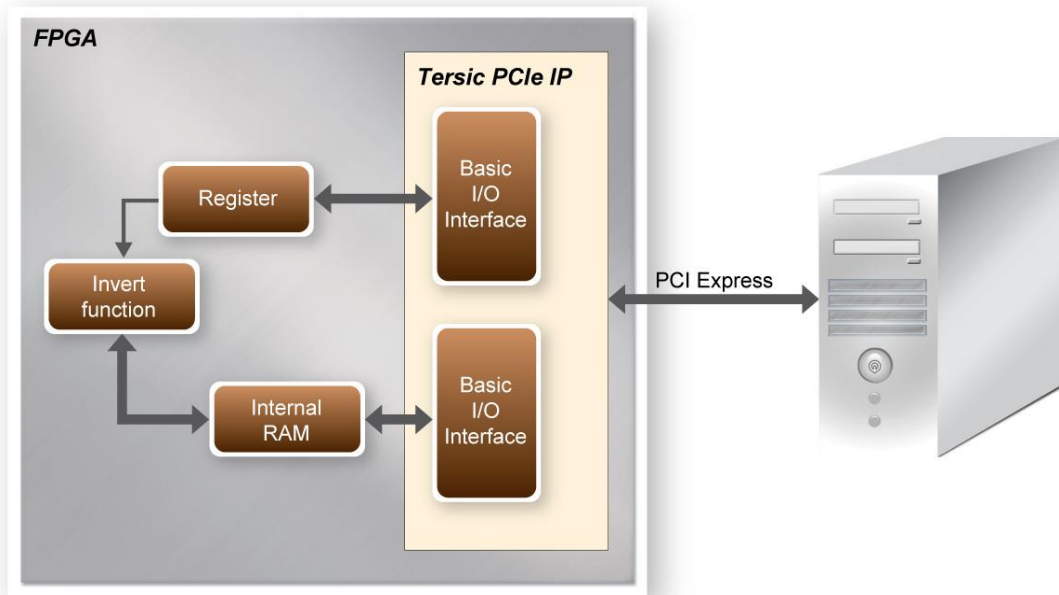

Figure 6–14 Block Diagram of Image Process in FPGA

■ Demonstration Files Location

The demo file is located in the folder: *PCIE_ImageProcess\demo_batch*

The folder includes following files:

- PC Application Software: *PCIE_Image_Demo.exe*
- FPGA Configuration File: *DE4_ImageProcess.sof*
- PCIe Library : *TERASIC_PCIE.DLL* and *wapi921.dll* (*TERASIC_PCIEx64.DLL* and *wapi1100.dll* for 64-bits Widnows)
- Demo Batch File : *test.bat*

■ Demonstration Setup

- Installed DE4 on your PC.
- Locate demo folder: *PCIE_ImageProcess\Demo_batch*
- Download *DE4_ImageProcess.sof* into the DE4 using Quartus II Programmer.
- Restart Windows.
- Installed PCIe driver if necessary. The driver is located in the folder

DE4_CDROM\demonstration\PCIe_SW_KIT\PCIe_DriverInstall

- Launch demo program PCIe_Image_Demo.exe

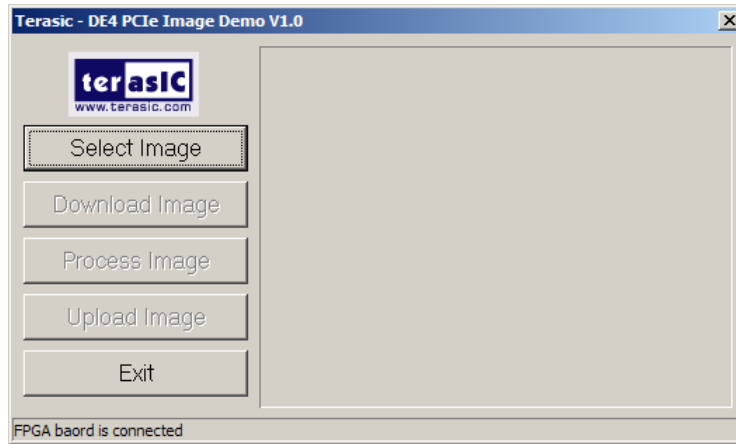

- Click “Select Image” to select a bitmap or jpeg file for image processing.



- Click “Download Image” to download image raw data into the local memory of FPGA.
- Click “Process Image” to trigger ‘invert’ image process.
- Click “Upload Image” to upload image to PC from local memory of FPGA to be displayed on the window demo application.

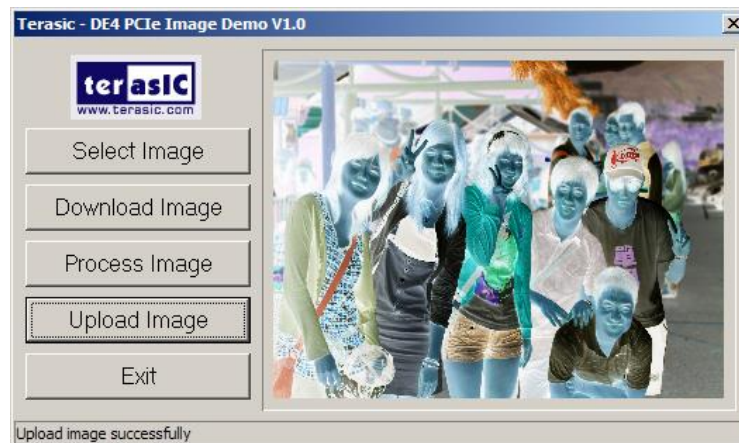

■ Design Tools

- Quartus II 9.1 SP2
- Borland C++ Builder

■ Demonstration Source Code Location

- Quartus Project: PCIE_ImageProcess
- Borland C++ Project: *PCIE_ImageProcess\pc*

■ FPGA Application Design

This demonstration uses the DMA channel of PCIe IP to download/upload the image into the internal RAM of FPGA, and controls the user register that switches the function which inverts the image data from the internal RAM.

■ PC Application Design

The software design defines some constant based on FPGA design as shown below:

```

#define PCIE_VID                0x1172
#define PCIE_DID                0xE001

#define IMAGE_WIDTH 320
#define IMAGE_HEIGHT 240

#define DEMO_PCIE_USER_BAR     PCIE_BAR1
#define DEMO_IMAGE_REG_ADDR    0x10
#define DEMO_IMAGE_DATA_ADDR  0

```

The vendor ID is defined as 0x1172 and the device ID is defined as 0xE001. The image dimension is defined as 320x240. The register address is 0x10 and memory address is 0x00.

A C++ class **PCIE** is designed to encapsulate the DLL dynamic loading for TERAISC_PCIE.DLL (loading TERAISC_PCIEx64.DLL under 64-bits Windows). A PCIE instance is created with the name **m_hPCIE**. To open a connection with FPGA the function is called:

```
m_hPCIE.Open(PCIE_VID,PCIE_DID,0); //0: first matched board
```

To download the raw image from PC to FPGA memory, the function is called:

```
m_hPCIE.DmaWrite(DEMO_IMAGE_DATA_ADDR, pImage, nImageSize);
```

where pImage is a pointer of the image raw data, and the nImageSize specifies the image size. In this reference design, nImageSize = 320x240x3 byte.

To start the image process, the function is called:

```
m_hPCIE.Write32(DEMO_PCIE_USER_BAR, DEMO_IMAGE_REG_ADDR, 1);
```

The image process is started whenever the register is written with any value.

To check whether the image process is finished, the control register is monitored by calling the function:

```
m_hPCIE.Read32(DEMO_PCIE_USER_BAR, DEMO_IMAGE_REG_ADDR, &dwStatus);
```

When the image process is finished, the value of dwStatus becomes zero.

To update the processed image from FPGA memory to PC, the function is called:

```
m_hPCIE.DmaRead(DEMO_IMAGE_DATA_ADDR, pImage, nImageSize);
```

Additional Information

Getting Help

Here are the addresses where you can get help if you encounter problems:

- Terasic Technologies
 9F, No.176, Sec.2, Gongdao 5th Rd,
 East Dist, Hsinchu City, Taiwan, 30070
 Email: support@terasic.com
 Web: www.terasic.com
 DE4 Web: de4.terasic.com

Revision History

Date	Version	Changes
2010.7	First publication	
2010.8	V1.1	PCIe Driver Installation Modified
2012.3	V1.2	PCIe Driver support 64-bit Windows
2015.01	V1.3	Update FPGA embeded ram size