

Sauter GmbH

Ziegelei 1
D-72336 Balingen
E-Mail: info@sauter.eu

Tel.: +49-[0]7433- 9933-199
Fax: +49-[0]7433-9933-149
Internet: www.sauter.eu

Instruction Manual Motorized Vertical Test Stand

SAUTER TVO

Version 1.3
11/2014
GB



PROFESSIONAL MEASURING

TVO-BA-e-1413



SAUTER TVO

Version 1.3 11/2015

Instruction Manual

Motorized Vertical Test Stand

Thank you for buying a SAUTER Test Stand for analogue Shore Hardness Testers. We hope you are pleased with your high quality test stand in table version and with its functional range. If you have any queries, wishes or helpful suggestions, do not hesitate to call our service number.

Summarize:

1	Construction	3
2	Function.....	3
3	Specification	3
4	Operation.....	4
5	Maintenance	4
6	Packing List.....	4
7	CE Declaration of Conformity	5

1 Construction

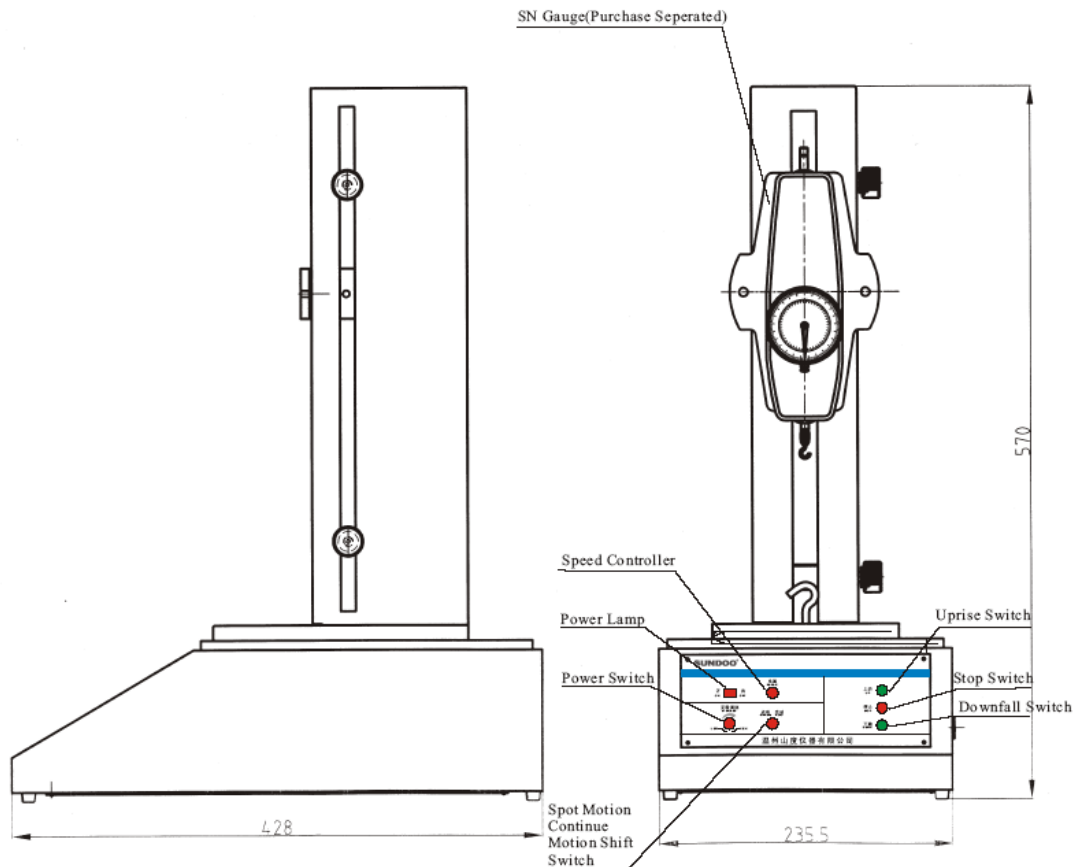

2 Function

The electrical vertical test stand TVO500N300 is applied in tension and compression tests. It can be assembled with push and pull gauges. The test stand is of good stability, has got a wide application range and it is easy to operate. Furthermore, it has the advantage of non-polar speed adjustment, manual and automatic operation and auto control of switch function. It is suitable in the field of rubber & plastic products, light industry & textile, construction of frame, complex material, wires & cables, automobile components, engine and scientific research.

3 Specification

Capacity	500N
Measuring stroke	300mm
Maximum measuring speed	500mm/min
Work voltage	Single-phase 220V
Rate flow	1.5A
Fuse of main circuit	3A
Fuse of controlling circuit	0.5A
Working temperature	20± 10°C
Store & Delivery temperature	-27°C up to +70°C
Relative Humidity	15% up to 80% RH

4 Operation

Examine before operation!

- A. The retainer has to be locked, the power has to be switched on by the power switch. The power lamp will be flashing.
- B. The test stand has to be examined if there is any abnormal sound with the test stand moving without load.

Manual (automatic) test

- A. The manual/automatic switch to manual operation position has to be turned on.
- B. The up/ down button on the stand has to be pressed, then the stand will begin to work.
- C. The button has to be loosened, then the test stand will stop working.

Adjustment of test speed

The test speed is adjustable in the course of testing or before the test.

The speed controller has to be turned to the required speed.

5 Maintenance

- A. The environment has to be kept clean; liquid and metal scraps have to be prevented from entering the engine box; otherwise there is the risk of electric shocks or moving components may be damaged.
- B. The column and motion pedestal has to be kept clean of lubricants.
- C. Some lubricant has to be added to the drive stroke and gear after some times of usage.
- D. The test stand has to be kept away from dust and moisture in case if it isn't used.

6 Packing List

- Test stand, main body
- M6 inner-hexagon Spanner
- 230 V power wire
- M6 clamp
- Instruction Manual

7 CE Declaration of Conformity



Sauter GmbH

Ziegelei 1
D-72336 Balingen
E-Mail: info@sauter.eu

Ziegelei 1
D-72336 Balingen
E-Mail: info@sauter.eu

Konformitätserklärung

Deklaracja zgodności WE uprawniająca do znaku CE
Konformitätserklärung für Geräte mit CE-Zeichen
Déclaration de conformité pour appareils portant la marque CE
Declaración de conformidad para aparatos con marca CE
Dichiarazione di conformità per apparecchi contrassegnati con la marcatura CE

D	Konformitäts- erklärung	Wir erklären hiermit, dass das Produkt, auf das sich diese Erklärung bezieht, mit den nachstehenden Normen übereinstimmt.
PL	Deklaracja zgodności	Niniejszym oświadczamy, że wyrób, którego dotyczy niniejsza deklaracja spełnia wymogi norm określonych poniżej.
E	Declaración de conformidad	Manifetamos en la presente que el producto al que se refiere esta declaración está de acuerdo con las normas siguientes
F	Déclaration de conformité	Nous déclarons avec cela responsabilité que le produit, auquel se rapporte la présente déclaration, est conforme aux normes citées ci-après.
I	Dichiarazione di conformità	Dichiariamo con ciò che il prodotto al quale la presente dichiarazione si riferisce è conforme alle norme di seguito citate.

Motorized vertical Test Stand: TVO

EU-Richtlinien	Normen
	EN 61326:1998+A1:1998+A2:2001

Datum 07.04.2014 r.
Date

Ort der Ausstellung 72336 Balingen
Place of issue

Signatur
Signature

Albert Sauter
SAUTER GmbH
Geschäftsführer
Managing director

SAUTER GmbH, Ziegelei 1, D-72336 Balingen, Tel.: +49-[0]7433/9933-199
Fax: +49-[0]7433/9933-149, E-Mail: info@sauter.eu, Internet: www.sauter.eu